



**City of
McMinnville**

FOX RIDGE ROAD AREA PLAN

DRAFT | DECEMBER 2023

DRAFT

ACKNOWLEDGEMENTS

City Council

Remy Drabkin – Mayor, City of McMinnville
Adam Garvin – Council President, Ward 3
Chris Chenoweth – Councilor, Ward 1
Sal Peralta -- Councilor, Ward 1
Kellie Menke – Councilor, Ward 2 (PAC Liaison)
Zack Geary – Councilor, Ward 2
Jessica Payne – Councilor, Ward 3

Planning Commission

Sidonie Winfield – Chair
Gary Langenwalter – Vice Chair (PAC Liaison)
Brian Randall
Megan Murray
Beth Rankin
Dan Tucholsky
Rachel Flores
Sylla McClellan (PAC Liaison)
Matthew Deppe

Project Advisory Committee

Sara Tucholsky – Chair
Sid Friedman – Vice Chair
Jim Culbert
Malcolm Greenlees
Sam Justice
Ellen Kersting
Allan Larsen
Stephen Leonard
Denise Murphy
Miriam Peterson
Sean Rauch
Brian Ruden
Steve Ryan
Peter Van Patten

Project Management Team

Heather Richards – Community Development Director
Tom Schauer, AICP – Senior Planner
Amanda Winter – Management Support Analyst
Noelle Amaya – Communications Manager
Susan Muir – Parks and Recreation Director
Matt Bernards – Engineering Technician
Joe Rinkes – Wastewater Services Supervisor

Consultant Team

Harper Houf Peterson Righellis, Inc.
SERA Architects, Inc.
DKS Associates
Johnson Economics

DRAFT

EXECUTIVE SUMMARY

The Fox Ridge Road Area Plan is intended to recognize the unique attributes of the Fox Ridge Road Area and guide future development through a vision and plan for a cohesive neighborhood within the study area. The Area Plan is a guiding land use document adopted as a supplement to the Comprehensive Plan.

The plan is organized into the following chapters:

Part 1. Introduction. This chapter summarizes the framework, basis, and requirements for conducting the area plan. This includes a summary of the area planning process and background information on the area.

Plan Purpose and Requirements. Comprehensive Plan Policies 187.60.00 – 187.90.40 outline the planning process UGB expansion areas, with the three successive steps of a Framework Plan, Area Planning, and Master Planning. This planning process guides the transition from unincorporated rural lands through annexation and urban development. Further detail is provided in the McMinnville Growth Management and Urbanization Plan (MGMUP) and the Zoning Ordinance.

The land uses in the Area Plan must be consistent with the Framework Plan and the identified land need for the UGB expansion area. Area Plans more specifically identify land uses, their locations, and their relationship to public facilities, natural resources, and existing urban uses.

Part 2. Existing Conditions. This chapter includes data that informs the planning of the Fox Ridge Road area. It includes a summary of plans, policies, and regulations applicable to the area plan; a summary of existing physical features, attributes, and assets in, or affecting, the planning area; information regarding public facilities and services; and synthesis and analysis of this data to provide context regarding potential issues, and opportunities and constraints that informed development of the area plan. This information was supplemented with information obtained through the community engagement work described in Part 3.

Traffic analysis and market analysis are provided in Part 3. While these assess and analyze existing conditions, they also address future forecast conditions that inform the plan, and also provide guidance used to evaluate the plan and identify potential issues associated with the different alternatives.

Part 3. Community Engagement and Plan Development. This chapter summarizes the community engagement process and plan development. The project is guided by a Project Advisory Committee appointed by City Council. At key stages of the project, information was shared with the community and input was obtained to identify issues, develop goals and polices, develop and evaluate alternatives, and select and refine a preferred alternative. Work sessions were also conducted with the Planning Commission and City Council, including a joint work session with the School Board. The results of those broader outreach efforts were part of an iterative process with the Project Advisory Committee obtaining input and guidance at key decision-making points in the process.

Part 4. Fox Ridge Road Area Plan. This chapter presents the final plan that was developed through the community engagement and plan development process.

The Plan Narrative. The plan narrative provides context for the plan and provides additional information to help understand the Vision, Goals, and Policies and the Area Plan Map, their relationship, and the context of the Area Plan to other planning documents and efforts.

DRAFT

The Vision, Goals, and Policies. The goals and policies were developed based on input received through the public process. These goals and policies refine and apply the Goals and Policies of the Comprehensive Plan and its supporting documents, to address the unique geographic area and characteristics of the Fox Ridge Road area. This Chapter includes goals and policies for the Fox Ridge Road area in the context of the Great Neighborhood Principles adopted as Polices 187.10-187.50 of the Comprehensive Plan.

This component of the plan addresses the vision for the area, relationships between land uses as part of a cohesive neighborhood, and Urban Design objectives to be achieved through the Area Plan and future Master Plans and development.

The Area Plan Map. The Area Plan Map addresses the Framework Plan in detail, more specifically identifying land uses, their locations, and their relationship to public facilities, natural resources, and existing urban uses. In addition to the map, the elements and attributes of the map and their relationships are also discussed in this chapter.

Part 5. Implementation. The plan will predominantly be implemented by following existing adopted procedures and standards. As individual property owners within the area choose to seek annexation to the City and development of their properties, they will follow the adopted procedures in Title 16 of the McMinnville Municipal Code and Chapter 17.10 of the Zoning Ordinance as applicable.

That process specifies the process for a property owner to apply for annexation, enter into an annexation agreement, prepare a master plan for the property, which is consistent with the area plan, obtain land use approvals for proposed development, and complete the annexation process.

Development will need to meet adopted City standards for development and land divisions, so it isn't necessary to create an entirely new set of development standards for the area, but unique issues applicable to the Fox Ridge Road area are identified in this plan that provide special guidelines and standards desired for the Fox Road area.

In addition, the implementation element identifies issues that may need to be addressed and coordinated through broader planning processes, such as the updates to the Transportation System Plan, and public facility plans.

Appendices. The appendices provide more detailed information regarding the information provided in the chapters of the plan. They are referenced at key points in this plan. They include more detailed existing conditions information, technical information, and summaries of the public engagement activities.

DRAFT

FOX RIDGE ROAD AREA PLAN

Contents

Part 1: Introduction	7
Purpose	7
Planning Process	7
Background	8
Part 2: Existing Conditions	9
Regulatory Context and Planning Framework	9
Local Context	12
Land Use and Zoning	13
Natural Features	14
Infrastructure and Services	15
Key Findings	18
Part 3: Community Engagement and Plan Development	22
Methods of Engagement and Community Input	22
Market Analysis	24
Transportation and Traffic Impact Analysis	24
Implications for the Area Plan	25
Part 4: Fox Ridge Road Area Plan	26
The Plan Narrative	26
The Vision, Goals, and Policies	31
The Area Plan Map	39
Part 5: Implementation.....	40
Overview	40
Comprehensive Plan Amendments	42
Zoning Ordinance Application	43

List of Figures

- Figure 1:** Study Area Context
- Figure 2:** Fox Ridge Road Area Map
- Figure 3:** MGMUP Framework Plan Map
- Figure 4:** Existing Conditions and Context
- Figure 5:** Zoning Map
- Figure 6:** Natural Hazards Overlay
- Figure 7:** Water Service Zone Map
- Figure 8:** Opportunities and Constraints Diagram
- Figure 9:** Preferred Land Use Concept Map

List of Appendices

- Appendix A:** Document Review and Existing Conditions Report
- Appendix B:** Online Survey Results Summary
- Appendix C:** Community Design Workshop Summaries
- Appendix D:** Project Advisory Committee Meeting Summaries
- Appendix E:** Market Analysis for High Density Residential and Commercial Uses
- Appendix F:** Transportation Analysis: Existing and Future Conditions

Part 1: Introduction

Purpose

The purpose of this Area Plan is to guide and support the annexation and future urbanization of the Fox Ridge Road Area. As specified in the McMinnville’s Comprehensive Plan and Framework Plan, the Fox Ridge Road Area Plan will provide a mix of residential, commercial, and civic or institutional uses while emphasizing parks, trails, and connectivity for a well-designed and connected neighborhood consistent with the Traditional Neighborhood model and Great Neighborhood Principles.

Planning Process

The Fox Ridge Road area planning process began in December 2022 with the establishment of the Project Advisory Committee (PAC) and the development of a plan for public engagement. The City advertised the opportunity to serve on the PAC, and the PAC was then appointed by the City Council. The process has since been guided by the Project Advisory Committee, with 14 members of the public, a City Council Liaison, and two Planning Commission Liaisons. The Project Advisory Committee includes a variety of interested parties which also includes representatives from the Fox Ridge Road area including residents, property owners, developers, and local neighboring residents. In addition to the Project Advisory Committee, key stakeholders were interviewed including the potential developer of the Neighborhood Activity Center, representatives from various public utilities, the Oregon Department of Fish and Wildlife, and the McMinnville School District.

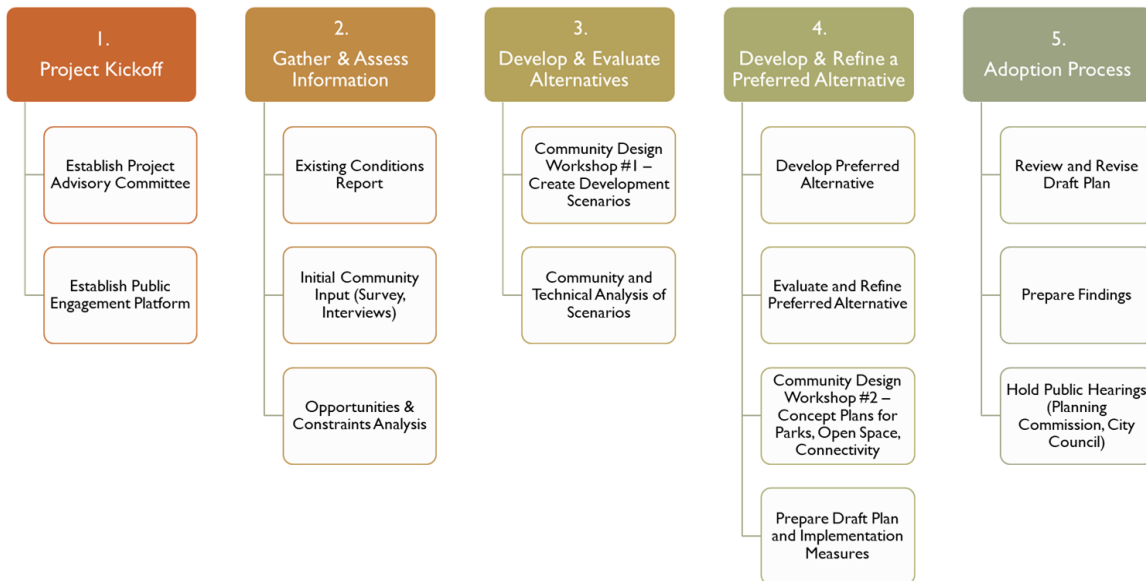

The area planning process also included a variety of community engagement and outreach activities to gather feedback. These opportunities for community members to provide their input included public participation at Project Advisory Committee meetings, in-person community design workshops, and an online survey. The City of McMinnville promoted these engagement opportunities through social media and newspaper ads, on the City website, and a City outreach booth, and provided updates for further involvement at each of these meetings. The City has worked closely with key stakeholders, property owners, local service providers, and the community to continuously gather valuable feedback through the area planning process.

Background

In 2020, the City of McMinnville adopted the McMinnville Growth Management and Urbanization Plan (MGMUP) on December 8th as part of the Comprehensive Plan and amended its urban growth boundary (UGB). The MGMUP amended McMinnville's UGB by 924 gross buildable acres, with most of this acreage placed into an Urban Holding (UH) comprehensive plan designation. All land within a UH comprehensive plan designation must undergo an area planning process prior to annexation into the city limits, rezoning, or urban development. The City of McMinnville has committed to investing and processing one area plan each year. The first area plan initiated by the City is the Fox Ridge Road Area Plan. The Fox Ridge Road Area is known as the area around Fox Ridge Road, and includes the potential future high school site owned by the McMinnville School District (see Figure 2). Collectively, the Fox Ridge Road study area is comprised of approximately 230 acres.



Figure 1. Study Area Context

The Fox Ridge Road Area Plan is expected to be primarily zoned for housing. However, the Area Plan includes a significant land use within the site that is owned by the McMinnville School District, located within the northern portion of the study area. This school district site is currently identified for the development of a future high school. The area planning process accounts for the connectivity and coordination with the future development of the high school site. Per the MGMUP Framework Plan, the Fox Ridge Road Area Plan will also provide an opportunity for a small Neighborhood Activity Center (NAC) along the area's NW Hill Road frontage between the Wallace Road roundabout and the intersection of Fox Ridge Road. This partial NAC aims to provide neighborhood serving commercial and office development, high-density residential development, and medium-density residential housing. The remaining residential land of the Fox Ridge Road study area is suitable for low-density residential housing, specifically within the southern and western portions where the topography exhibits steeper slopes. In order to support this newly developed residential area and provide further services, the Fox Ridge Road Area Plan will incorporate one neighborhood park located within a ½ mile distance from all residences in the study area. The plan will also include a natural resource park to preserve existing natural features, along with a greenway system for bike and pedestrian connectivity throughout the study area and with connectivity of the Fox Ridge Road area to other areas.

Part 2: Existing Conditions

Regulatory Context and Planning Framework

The Fox Ridge Road Area Plan will be adopted as a supplement to the McMinnville Comprehensive Plan and adopted by the City Council as a guiding land use document. The Area Plan document, along with the final land use concept, embodies the development principles of the Comprehensive Plan, including the MGMUP, MGMUP Framework Plan, McMinnville Comprehensive Plan Goals and Policies, and other applicable City land use policies and standards. The MGMUP provides guidance for the planning and development of fully integrated, mixed-use, pedestrian-oriented neighborhoods. The final land use concept will help guide future development patterns and is expected to be consistent with the:

- 1) **McMinnville Growth Management and Urbanization Plan:** The guidelines of the Traditional Neighborhood model, as described in the McMinnville Growth Management and Urbanization Plan.
- 2) **MGMUP Framework Plan:** Neighborhood Activity Centers (NACs) to meet neighborhood commercial land needs as identified in the MGMUP Framework Plan, supports surrounding residential development, and provides opportunities for open space, parks, and trails.
- 3) **McMinnville Comprehensive Plan:** Including the City's adopted Great Neighborhood Principles, as described in Comprehensive Plan Policies 187.10 through 187.50.
- 4) **Parks, Recreation and Open Space Master Plan:** The City's Parks and Recreation vision and facility guidelines.

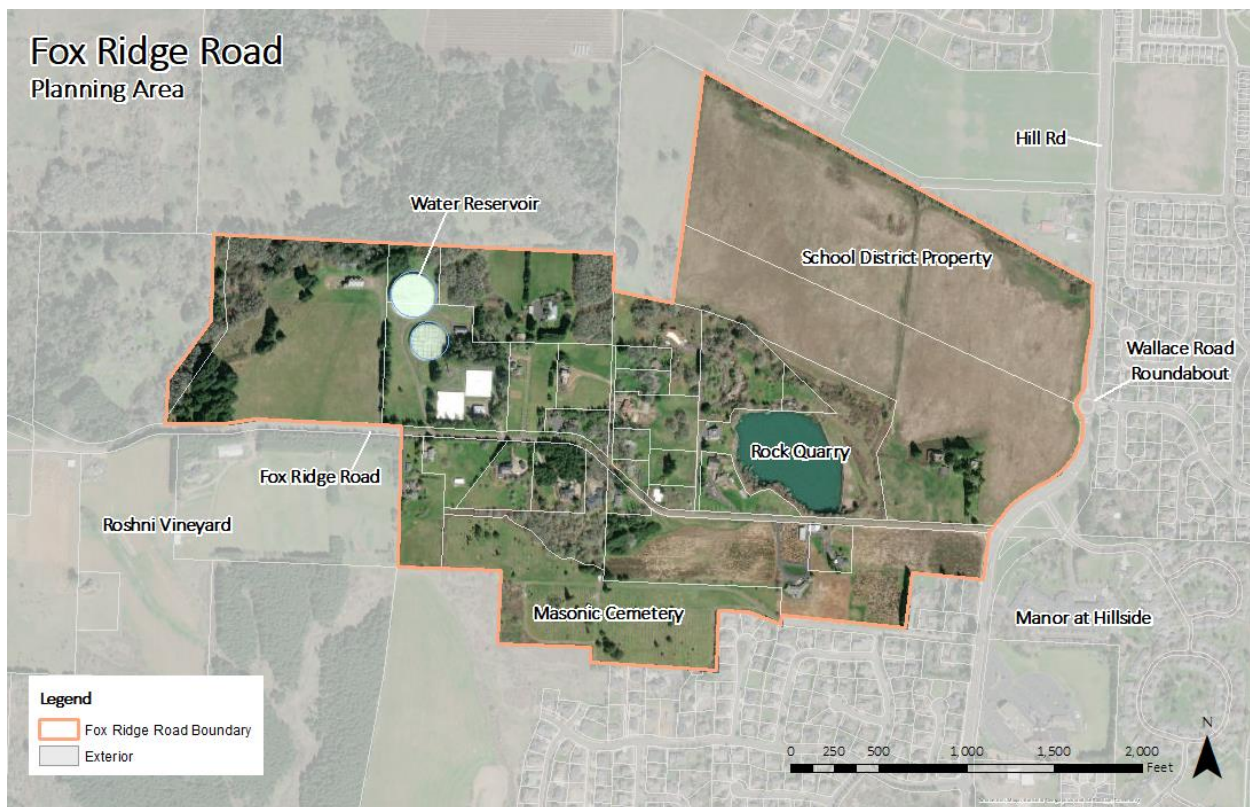

Figure 2. Fox Ridge Road Area Map

DRAFT

McMinnville Growth Management and Urbanization Plan

Traditional Neighborhood Model Guidelines

As highlighted in the MGMUP, McMinnville’s plan for urbanization is modeled around the planning and development of a “traditional neighborhood,” designed to be fully integrated, mixed-use, and pedestrian oriented. This type of development includes narrower streets that emphasize pedestrian orientation and scale, highly connected street patterns with small blocks or grids, streets lined with trees and sidewalks on both sides, and diverse housing types and lot sizes that are intermixed throughout the neighborhood. Uses and housing types are mixed and in close proximity to one another, with public spaces such as neighborhood parks or plazas serving as focal points for community interaction. As an essential feature, the McMinnville model for a traditional neighborhood calls for a neighborhood activity center at the heart of the neighborhood to provide opportunities for social interactions, structure to surrounding land uses, and neighborhood identity. The concept of a traditional neighborhood aims to minimize traffic congestion, suburban sprawl, infrastructure costs, and environmental degradation.

To be consistent with the MGMUP, the Fox Ridge Road Area Plan follows the guidelines set forth for the development of a traditional neighborhood model. Key considerations for the study area include mixed-use planning that integrates diverse commercial and residential developments, pedestrian oriented and connected streets, and public green spaces as social gathering opportunities. A neighborhood activity center is expected to be a focal point of the study area. The McMinnville Zoning Ordinance defines a Neighborhood Activity Center as, “a physically and aesthetically unified area, that serves as the center of a larger surrounding neighborhood, where all elements and land uses are designed to function as an integrated whole (rather than as a series of unconnected, unrelated developments). Neighborhood Activity Centers consist of a Focus Area with commercial, institutional, office uses, and other mixed-use activities needed to support a specified geographic area. These centers also may include a Support Area with high- and medium-density residential uses that supports the non-residential uses in the center.”

McMinnville Framework Plan

Neighborhood Activity Centers (NACs)

The MGMUP emphasizes Neighborhood Activity Centers as the most critical element of the City’s growth management and land use plan. Surrounding the neighborhood activity center are residential uses with the highest-density housing developments that progressively decrease in density outward from the activity center. According to the MGMUP Framework Plan, the Neighborhood Activity Center should:

- provide local context with the ability to foster the development of a traditional neighborhood;
- have the ability to accommodate higher intensity development and be strategically located based on the proximity to vacant buildable land;
- be located at major street intersections with their service areas extending to a group of neighborhoods ranging from a one to three-mile radius.

Focus Area of the activity center should contain facilities necessary for day-to-day activity (such as personal services, grocery and convenience shopping, schools, places of worship, limited office space, public plazas or parks) and ideally be located within close proximity to one another in the focus area so that all essential services for the subarea are easily accessible in a single stop.

Support Areas that surround the activity center’s focus area should contain the neighborhood’s high- to medium-density housing options and enables the highest concentration of population to easily access the focus area within walking distance (reducing the number of automotive trips for daily needs or services and allows for a single transit stop to serve the shops, services, and adjacent higher-density housing in the area).

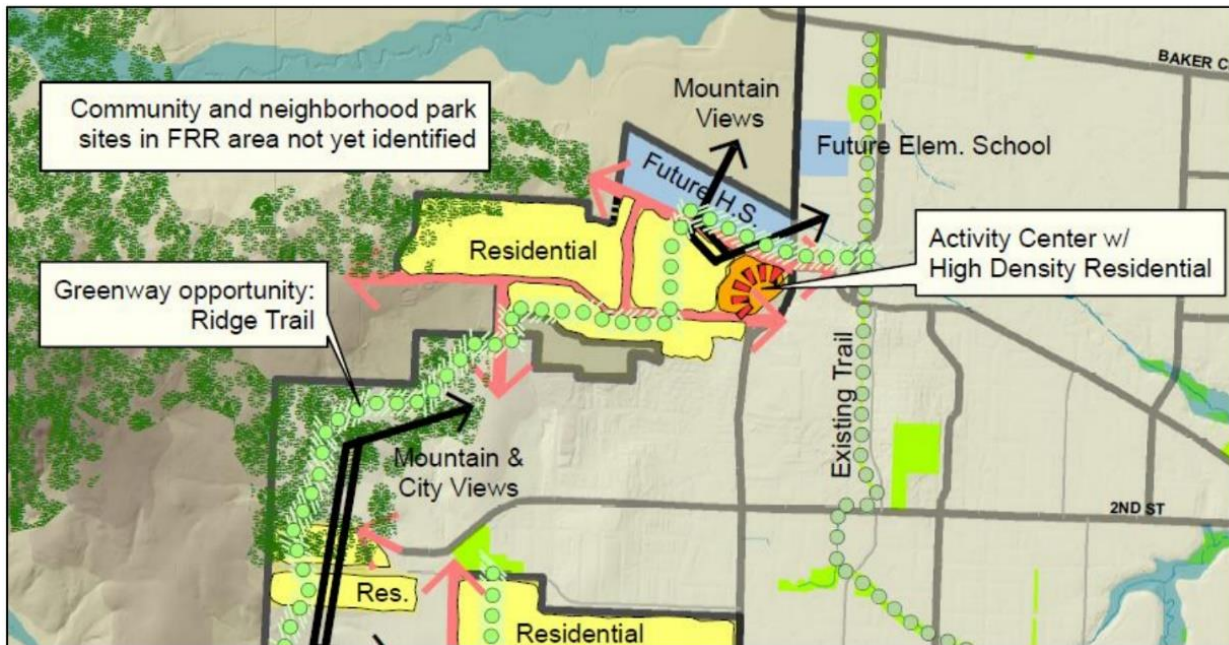

Figure 3. MGMUP Framework Plan Map

Shown in the MGMUP Framework Plan, the Fox Ridge Road Area Plan provides an opportunity for a partial Neighborhood Activity Center. The modified and reduced activity center will be approximately 5 – 10 acres, with approximately 1 – 2 acres of commercial and office development to serve the neighborhood, approximately 2 acres of high-density residential development (R-5), and approximately 2 – 5 acres of medium density residential housing. This mixed-use center is proposed to be located along the study area’s NW Hill Road frontage between the Wallace Road roundabout and the intersection of Fox Ridge Road (see Figure 3). The remaining residential land of the Fox Ridge Road study area is suitable for lower density residential housing, specifically within the southern and western portions where the topography exhibits steeper slopes. The Fox Ridge Road Area Plan will incorporate one neighborhood park of approximately 3 – 5 acres in size located within a ½ mile from all residences in the study area. The plan will also include a natural resource park to preserve existing natural features, along with a greenway system for bike and pedestrian connectivity throughout the study area. The location, uses, and accessibility of the neighborhood activity center ensures the Area Plan’s consistency with the City’s adopted Great Neighborhood Principles described in the MGMUP Comprehensive Plan.

MGMUP Comprehensive Plan

Great Neighborhood Principles

Adopted in 2019, the Great Neighborhood Principles are described by Comprehensive Plan Policy 187.10 as a means to guide the land use patterns, design, and development of the places that McMinnville citizens live, work, and play. These principles ensure the livability, accessibility, safety and beauty of all new development or redevelopment. In order for the Fox Ridge Road Area Plan to be consistent with these principles, Comprehensive Plan Policy 187.50 describes specific directions on how to achieve each principle as it refers to design, location and orientation of these necessary neighborhood resources. By following the model of a traditional neighborhood and planning around the centralization of a partial neighborhood activity center, the overall development of the area plan will likely achieve each individual principle.

(Please refer to Part 3: Community Engagement for the list of Great Neighborhood Principles.)

Parks, Recreation, and Open Space Master Plan

The City of McMinnville created and published its Parks, Recreation, and Open Space Master Plan in 1999 to meet the parks and recreational needs of the community, while ensuring natural resources crucial to the character of the City are protected and enhanced. The Park and Recreation Department holds a central role in shaping the changing character of the City, as recreational opportunities continue to build community and help encourage residents to achieve active, healthy lifestyles. As with the Parks Master Plan, the Fox Ridge Road Area Plan must plan for the City's population growth and increasing diversity. The Fox Ridge Road study area has its own existing unique natural features and opportunities for new parks and recreation services. The Fox Ridge Road Area Plan addresses the minimum Level of Service Standards of the Parks Master Plan as well as the minimum requirements in the MGMUP Framework Plan. The City is in the process of updating the Parks, Recreation, and Open Space Master Plan, and the work is proceeding in coordination among planning efforts, including the Fox Ridge Road Area Plan.

Local Context

The Fox Ridge Road study area is located west of NW Hill Road surrounding Fox Ridge Road and consists of approximately 230 acres, with about 30 existing parcels ranging in size from less than an acre to over 40 acres. The study area is characterized by its moderate to steeply sloping terrain, dense stands of mature trees, and the expansive views of the surrounding lands. The study area primarily consists of land zoned for agricultural and rural-residential use, with rural residential single detached homes that are situated to take advantage of the scenic views. There are several committed lands within the study area including the school district site, the water reservoir property owned by McMinnville Water and Light, and the Masonic Cemetery. Directly southwest of the study area is the Hillcrest Master Plan residential development, and about 0.5-mile north along Baker Creek Road is a new construction mixed-use development project with 144 residential units and 30,000 square feet of additional commercial space.



Figure 4. Existing Conditions and Context

DRAFT

Land Use and Zoning

Due to the existing topography of the study area, the large parcels along Fox Ridge Road are most suited for larger low-density residential properties, while the eastern portions of the study area are flatter and more suitable for potential mixed-use and medium- to high-density residential development. A 42-acre site on the north side of the study area is owned by the McMinnville School District and is currently identified for the potential development of a future high school. Per the Framework Plan, the partial Neighborhood Activity Center should be strategically located near the intersection of Fox Ridge Road and Hill Road to provide services and amenities to the diverse residential developments proposed within the study area.

The Fox Ridge Road study area is currently designated with the Urban Holding (UH) Comprehensive Plan map designation, except for the School District Property. Until properties are annexed into the City, they retain their current County rural zoning designations and the applicable County zoning and land use regulation continue to apply to these properties. The surrounding land uses include low-density residential (R-1 and R-2) zoning directly south and east of the study area, and additional medium-density, multiple-dwelling residential (R-4) zoning southeast of Fox Ridge Road. To the west and north of the study area are county zoned exclusive farmland (EF-80). The school district site is within City limits and is currently zoned R-4 PD (Planned Development), which permits public schools conditionally. The Planned Development ordinance applicable to the properties specifies its use for a school.

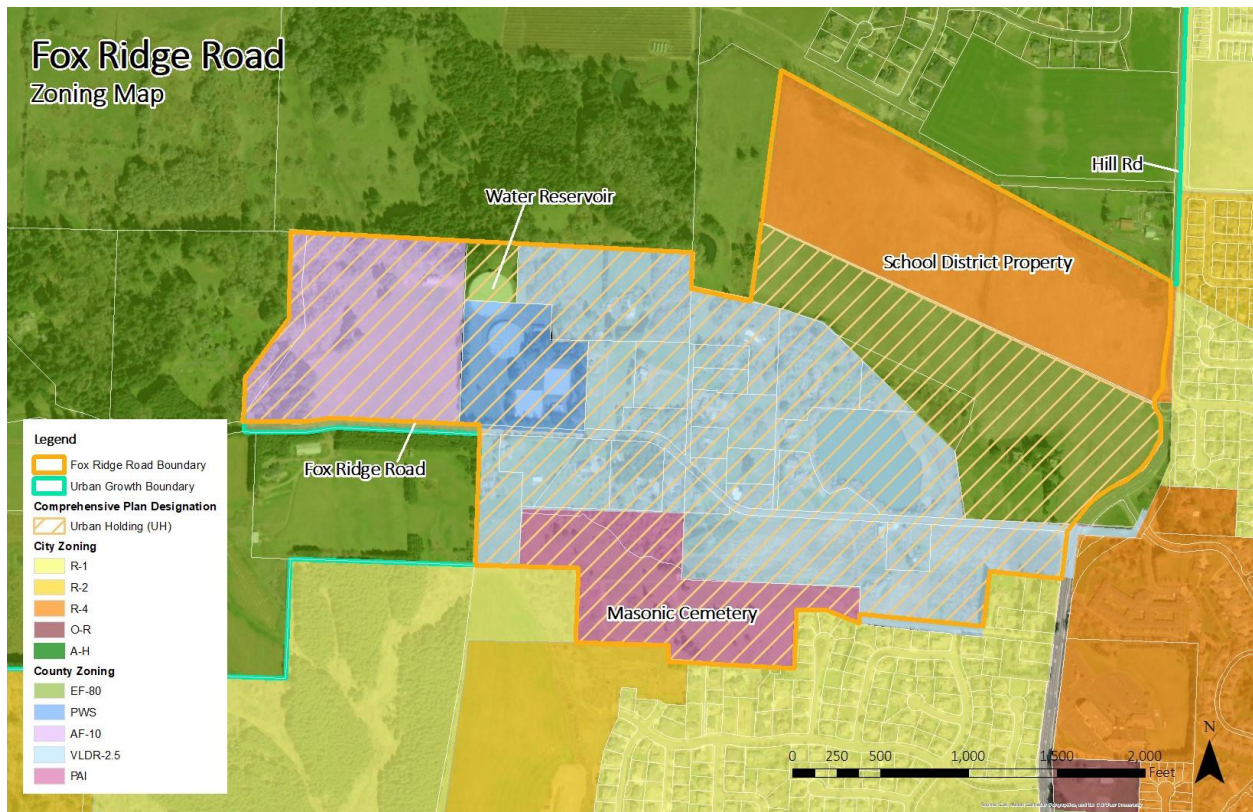

Figure 5. Zoning Map

Natural Features

Topography And Geotechnical Conditions

The City made initial findings describing the topography of the Fox Ridge Road study area within the MGMUP Phase 1 Expansion Land Study Areas of the Urbanization Report. Specifically, the majority of the study area consists of gradual to steeply sloping land, with some areas to the west exceeding a 15 percent slope. The lowest point of the study area is located in the southeast corner and sits at 287 feet above sea level (ASL), gradually increasing to the steepest slopes located in the west side of the study area and topping out at over 400 feet of elevation ASL.

Hazards and Natural Features

There are no floodplains identified within the study area. However, recent mapping conducted by the City of McMinnville to identify natural hazards and natural features in conjunction with Statewide Planning Goals 5 (Natural Resources) and Goal 7 (Natural Hazards) identified hazardous areas based on topographical conditions, significant tree groves, and scenic viewpoints along ridgelines to the north and south of Fox Ridge Road. The City is in the public hearing process for consideration of a proposed Natural Hazards Inventory and Management Program. This includes proposed overlay zones for Natural Hazard Mitigation (NH-M) Zones and Natural Hazard Protection (NH-P) Zones, which have been identified in the overlay map below. Areas identified with natural hazards have development constraints that will need to be considered along with the development standards of the underlying base zone. The conservation of natural greenspaces and greenways will serve to protect the dense stands of mature trees and provide habitat for protected avian species.

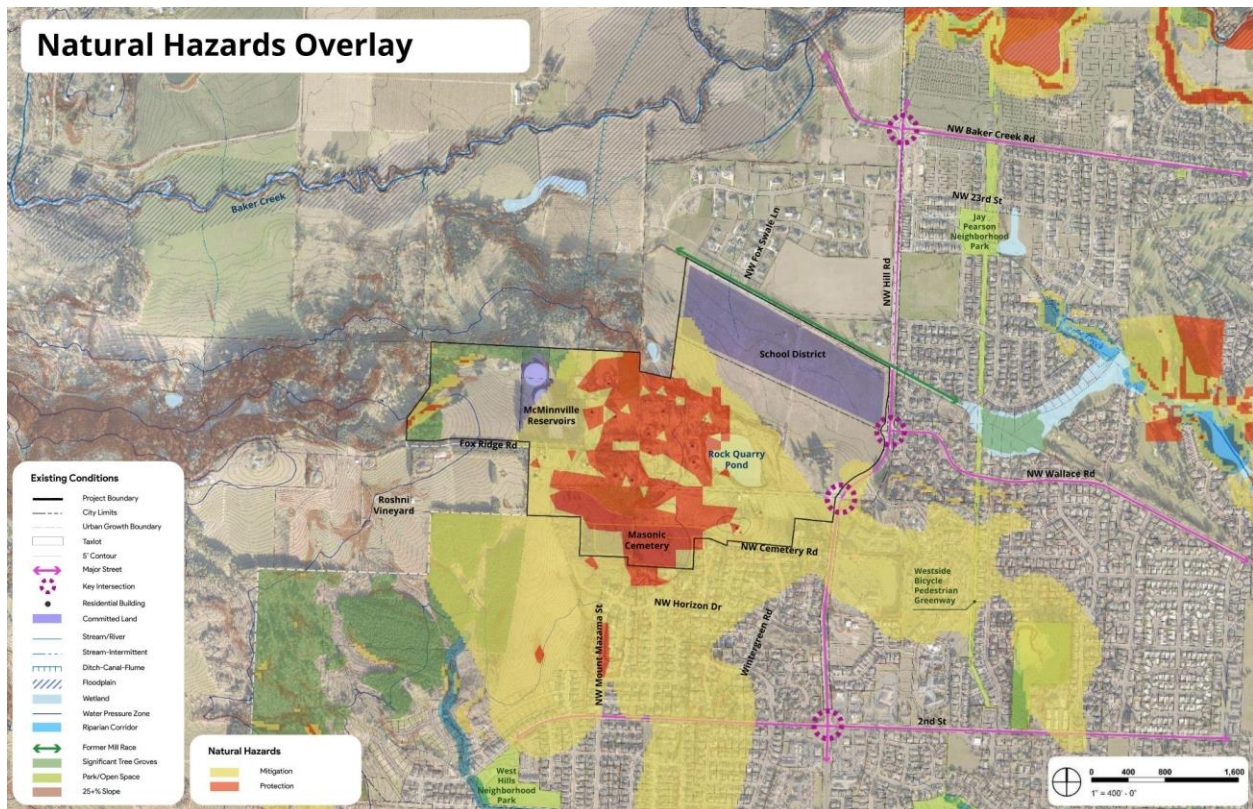

Figure 6. Natural Hazards Overlay.

Habitat Conservation and Wildlife

The Fox Ridge Road study area includes several existing natural and geographic features that provide an excellent opportunity to conserve and limit impacts from urbanization on the habitat and wildlife. Natural greenspaces or greenways will be considered to connect the Fox Ridge Road Area to the West Hills and Redmond Hill Road areas. This greenway/greenspace could also minimize impacts to the significant tree stands in the Fox Ridge Road and West Hills areas that currently provide habitat for protected avian species, such as the Western Bluebird, White-Breasted Nuthatch (Slender-Billed), and Oliver-Sided Flycatcher.

Other Natural/Limiting Features

Rock Quarry Pond

Large gravel quarry filled with water, centrally located within the study area near the base of Fox Ridge Road and adjacent to the location for the Neighborhood Activity Center. Currently serves as stormwater drainage and retention, providing supplemental irrigation to properties outside of the study area.

Masonic Cemetery

Occupies nearly 70 percent of the southern boundary of the study area. Must be protected in place and buffered from potential surrounding uses.

McMinnville Water and Light

Owns a large property near the center of the study area that houses four above-ground water reservoirs.

Infrastructure and Services

Transportation

Fox Ridge Road itself is a paved, county road with no sidewalks, curb, or gutter. The road extends westward from NW Hill Road providing the only current means of public vehicular access into the study area. Fox Ridge Road generally travels along the ridgeline that cuts east-west through the study area's midsection. Additional access to individual parcels within the study area is provided by long and narrow private driveways. The right-of-way dimension for Fox Ridge Road measures 40-feet in width and includes a constructed paved surface that averages 25-feet in width with gravel shoulders on either side. The road will require improvements as the area urbanizes to meet City design standards. To meet today's urban standard, an additional 10-feet of right-of-way width, removal and reconstruction of the existing subgrade, construction of a paved travel surface at a minimum 26-feet in width, as well as 5-foot wide sidewalks on both sides of the street, curbs and gutters would be required.

Pedestrian and Bicycle Connections

Bike and pedestrian connectivity are integral to the Fox Ridge Road Area Plan, with consideration of connecting to the existing trails and linear parks (BPA and Westside trail systems) that are located just east within the existing Urban Growth Boundary (UGB). The existing trail system may potentially be linked via Wallace Road to the study area. There are currently no bike or pedestrian facilities along Fox Ridge Road. Hill Road was improved to its current configuration, completed in 2018. There are existing bike lanes along both sides of Hill Road and sidewalks along both sides where abutting lands are within the UGB. Creating safe and accessible bike lanes and pedestrian routes within the study area will require further evaluation of traffic calming design along NW Hill Road and improvements along Fox Ridge Road.

Transit

The City will also be coordinating with Yamhill County Transit as part of the outreach for the Fox Ridge Road Area Plan in order to better understand the potential for future public transit services to connect Baker Creek Road, Hill Road, and 2nd Street. Yamhill County Transit updated their transit plan in 2018, with future short- to long-term service expansions discussed within the region. The transit plan indicates that,

DRAFT

“McMinnville’s R-3 residential zoning district allows nearly 12 units per acre and the R-4 residential district allows for higher-density developments (over 20 units per acre), which could support transit service that is more frequent than today; however, current residential density in the city is relatively low, even in areas currently zoned for medium- or higher-density housing.” The plan identifies potential future service along Hill Road which could ultimately benefit the Fox Ridge Road study area. Higher densities and other plan elements would potentially increase the demand for these services sooner than later.

Utilities (Water, Sewer, Stormwater, And Other)

Water

The study area’s primary source of domestic water is currently individual and private wells. The McMinnville Water and Light “Water System Master Plan” states that this area is located above the current water service area and cannot be provided public water without constructing an upper level system. This would require the acquisition of land in order to build a new reservoir (southwest of this study area at an elevation of some 510 feet), construction of two reservoirs, a pump station, and transmission lines connecting the existing reservoirs with the planned reservoirs and pump station. Properties located within Water Service Zone 1 (shown in Figure 7) are currently served with public water.



Figure 7. Water Service Zone Map

Sewer

Due to the topography of the study area, sanitary sewer effluent would gravity flow in two directions: to the north into the Michelbook drainage basin; and, to the south into the Cozine drainage basin, requiring additional trunk line extensions beyond what would otherwise be required. According to the City of McMinnville Engineering Department, there are downstream capacity limitations to both the Michelbook and Cozine drainage basins. Capacity limitations will be evaluated as the Wastewater Master Plan is updated in the future.

DRAFT

Stormwater

There are currently no existing storm pipes within the study area. However, existing storm pipes run throughout the neighborhoods both south and east of the Fox Ridge Road area that may be connected to any new storm pipes extended as part of the area plan. Within the Fox Ridge Road area is the North Cozine and Baker Creek Basin, as well as the West Cozine Creek Basin to the south. There is also a large gravel borrow pit that is now filled with water located in the eastern portion of the study area. Prior to any new development, the City will likely require the construction of water quality treatment and detention facilities prior to being discharged into the public stormwater line.

Electric

The study area is currently served by McMinnville Water and Light. There are existing feeders on North Hill Road that would have to be upgraded to accommodate the additional projected load from new developments. The Fox Ridge Road Area is already serviced, however, future coordination with municipal utilities will be coordinated at the time of development of individual properties.

Community Facilities

Resource	Facility	Address	Location
Schools	Newby Elementary School	1125 NW 2 nd St	1 mile – East
	Duniway Middle School	575 NW Michelbook Ln	1 mile – East
	Memorial Elementary School	501 NW 14 th St	1.5 miles – East
	McMinnville High School	615 NE 15 th St	2 miles – East
Higher Education	Linfield University	900 SE Baker St	2 miles – SE
	Chemeketa Community College	288 NE Norton Ln	3.5 miles – SE
Parks	Jay Pearson Neighborhood Park	2120 NW Yohn Ranch Dr	0.6 miles – NE
	Westside Bicycle and Pedestrian Greenway	Runs north/south NW Baker Creek Rd to SW 2 nd St	0.5 miles – East
	McMinnville Linear Park	Runs east/west S. Agee St to SW Westvale St	0.6 miles – SE
Hospitals	Oregon Whole Health	349 SE Baker St	1.6 miles – SE
	Physicians Medical Center	2435 NE Cumulus Ave	3.3 miles – SE
	Willamette Valley Medical Center	2700 SE Stratus Ave	3.3 miles – SE
Police Stations	McMinnville Police Department	121 SE Adams St	1.6 miles – SE
	Yamhill County Sheriff's Office	535 NE 5 th St #143	1.8 miles – SE
Fire Station	McMinnville Fire Department	175 E 1 st St	1.6 miles – SE
Playground	Scotty's Playhouse Indoor Playground	700 NW Hill Rd	0.1 mile – East
Senior Care	The Manor at Hillside Retirement Community	900 NW Hill Rd	0.1 mile – East
	The Village at Hillside Assisted Living Facility	440 Hillside Pkwy	0.3 mile – SE
	Traditions at Hillside Retirement Community	300 Hillside Pkwy	0.3 mile – SE
	Vineyard Heights Assisted Living Facility	345 SW Hill Rd	0.5 mile – South
	McMinnville Memory Care	320 SW Hill Rd S	0.5 mile – South
Cemetery	Masonic Cemetery	NW Cemetery Rd	0 miles

DRAFT

The proximity of these community facilities further informs the area planning process, providing context to existing facilities, amenities, services, and opportunities for new connections. By understanding the distance of existing parks and playgrounds, the plan can prioritize pedestrian connectivity to these areas to link newly proposed parks and trails to the existing system of these facilities. Nearby resources, such as senior care facilities and schools, can be accounted for when considering new land uses and so on.

Key Findings

Land Use and Zoning

- The Fox Ridge Road Area Plan is expected to be adopted in reference to the MGMUP to ensure the study area complies with the goals and objectives established through the area planning process
- A significant land use within the area will be the 42-acre site owned by McMinnville School District that is slated for the potential development of a future high school.
- The plan will include a Neighborhood Activity Center that allows for small scale commercial and office development, NAC park/plaza, and high-density residential development within the center.
- The Neighborhood Activity Center should be strategically located to provide services and amenities to the diverse residential developments proposed within the study area.
- A neighborhood park is to be located within ½ mile of all residences within the neighborhood.

Natural Features

- Topographically, the majority of the study area consists of gradual to steeply sloping land that may affect the constructable residential densities and related utilities.
- A majority of the area's soils are of moderate to poor permeability which limits the types of stormwater facilities that can be utilized in support of future urban development.
- The area plan will need to plan for a useable open green space network that includes greenways and trails throughout the area to improve the walkability and accessibility of the study area.
- Two ridges running parallel to Fox Ridge Road, one on the north side and one to the south, further divide the properties along Fox Ridge Road from flatter areas at the northeast corner of the study area and land immediately to the south.
- Recent mapping conducted by the City of McMinnville to identify natural hazards and natural features in conjunction with Statewide Planning Goals 5 and 7 identified significant tree groves at the western edge of the study area, and scenic viewpoints along ridgelines to the north and south of Fox Ridge Road. It will be important to conserve natural greenspaces and greenways that may also serve to protect the dense stands of mature trees that provide habitat for protected avian species.
- Relatively flat properties at the northeast corner of the study area and at the base of Fox Ridge Road, near its intersection with NW Hill Road, are less impacted by slopes and closer to existing utilities.
- A large remainder of land within the Fox Ridge Road Area Plan is most suitable for lower density residential housing development due to steep slopes.
- Preliminary mapping of potential NH-P and NH-M overlay zones indicate that development may be limited by natural hazards on the middle portion of Fox Ridge Road, above the cemetery and tree farm properties at the base of the hill, and below the westernmost edge of the study area. In combination with other development constraints (parcelization, serviceability), new residential development along the higher portions of Fox Ridge Road may take place later than other portions of the area, or at a lower intensity. These areas could be evaluated in conjunction with identified natural features and habitat areas for possible designation of open space areas and/or transfer of development rights.

DRAFT

Infrastructure and Services

- If a different street standard is applied to Fox Ridge Road, future development would require road frontage improvements to meet City standards, including improvements to the right-of-way, remove and reconstruction of the existing subgrade, construction of paved travel surfaces, as well as 5-foot minimum sidewalks along both sides of the street, curbs and gutters.
- Connectivity and coordination with the development of the high school site, adjacent to the proposed mixed-use concept plan development, will be critical to the area plan.
- Bike and pedestrian connectivity should occur between the Fox Ridge Road area and existing trails and linear parks throughout McMinnville.
- Coordination with Yamhill County Transit should occur to provide public transit services, especially in conjunction with the proposed partial Neighborhood Activity Center location.

Wallace Road Extension

- The three-legged roundabout at the intersection of NW Hill Road and Wallace Road provides an opportunity to extend Wallace Road westward for access to the location of the Neighborhood Activity Center and the McMinnville School District property.
- A Wallace Road extension would provide access for the future high school site and the Neighborhood Activity Center on TL 700. Due to these adjacent uses, the Wallace Road extension will likely be the most used street in the study area, by all modes of travel, making the design and alignment of the road particularly important.

Regulatory Context and Planning Framework

- The Area Plan will be adopted as a supplement to the McMinnville Comprehensive Plan, and act guide for future urbanization of the land located within the Fox Ridge Road Area Plan.
- The Area Plan will reflect the principles of the MGMUP, MGMUP Framework Plan, McMinnville Comprehensive Plan and other applicable City land use policies and standards including:
 - The guidelines of the Traditional Neighborhood model
 - Standards for a partial Neighborhood Activity Center
 - The adopted Great Neighborhood Principles (Comprehensive Plan Policies 187.50)
- The MGMUP Framework plan identifies potential planned uses such as a partial or half Neighborhood Activity Center (5 – 10 acres) with commercial and office development (1 – 2 acres), medium-density residential development (2 – 5 acres) and high-density residential development (2 acres) located at the perimeter of the Neighborhood Activity Center. This will also include a Neighborhood Park located within a ½-mile distance from all residences in the study area, and a natural resource park.

School District Property

- McMinnville School District owns a 41-acre site at the northern edge of the study area, intended for a future high school. The site is a parallelogram, extending only about 700 feet in depth from the anticipated future extension of Wallace Road.
- The future high school site occupies a significant portion of the flat land at the northeast corner of the study area that is most easily accessed and serviced by existing utilities. Depending on the size of the high school, utility needs may vary. The timeline for development is uncertain.
- The district has not adopted specific programming or plans for a high school at this time, pedestrian, bicycle, and vehicular connectivity to the school will need to anticipate the future layout of the site.
- The shape of the property may pose challenges for configuring a high school, depending on the eventual programming intended for the facility.

DRAFT

Other Permanently Occupied Sites

- Two of the larger properties within the southern portion of the study area are occupied by uses that have been committed to specific uses that make them unlikely to redevelop at any time in the future:
 - The Masonic Cemetery occupies a 21-acre site, occupying nearly 70 percent of the southern boundary of the study area.
 - McMinnville Water and Light owns 13-acres near the center of the study area, along Fox Ridge Road, that houses four above-ground water reservoirs.
- These sites do not directly impact the development potential of neighboring properties but could interrupt the continuity of annexation and utility extensions, as property is urbanized from the existing City limits at the base of the hill. Annexations contiguous to City limits could occur relative to the City limits to the east or the south.

Rock Quarry Pond

- A large gravel quarry, now filled with water, is centrally located within the study area, near the base of Fox Ridge Road and adjacent to the approximate location suggested in the Framework Plan for the Neighborhood Activity Center. The gravel pit currently stores runoff from uphill lands and provides supplemental irrigation to properties outside of the study area.
- The pond created on the gravel pit site could provide a feature to a future park site or amenity for development in the vicinity.
- A park site or public park at the gravel pit site would occupy a possible connection point between the higher ground along Fox Ridge Road and potential future locations for a high school and Neighborhood Activity Center. However, the pond itself is not visible from either of these lower elevation sites.
- The pond currently plays a role in stormwater drainage and retention, and changes in configuration may have impacts in and around the site.

Opportunities and Constraints

The key findings listed above have helped inform the “Opportunities and Constraints Diagram” presented and utilized at Community Design Workshop #1 and has also been referenced in several Project Advisory Committee meetings to provide context (see Figure 8). This diagram summarizes the opportunities for various land uses, development patterns, building relationships, open spaces, and connections, as well as any key constraints that would need to be overcome in order to realize those opportunities.

Opportunities

- Potential gateways to the study area have been identified at the Hill Rd/Wallace Rd intersection and the Hill Rd/Fox Ridge Road intersection.
- New street connections identified connect the Fox Ridge Road study area to the Hillcrest Master Plan development, to the location of the Neighborhood Activity Center, through the School District site, and to both NW Hill Road and Wallace Road.
- Landmarks include the existing Rock Quarry Pond for preservation as a key community feature.
- Areas of significant tree groves have been identified for tree canopy preservation.
- Scenic viewpoints are shown that take advantage of the steep topography of the study area.

Constraints

- Committed lands include the School District site, Masonic Cemetery, and McMinnville Reservoirs.
- Steep slopes surpassing 25%+ will severely limit development due to topographical constraints.
- An existing easement from the Rock Quarry Pond runs through the proposed NAC site.

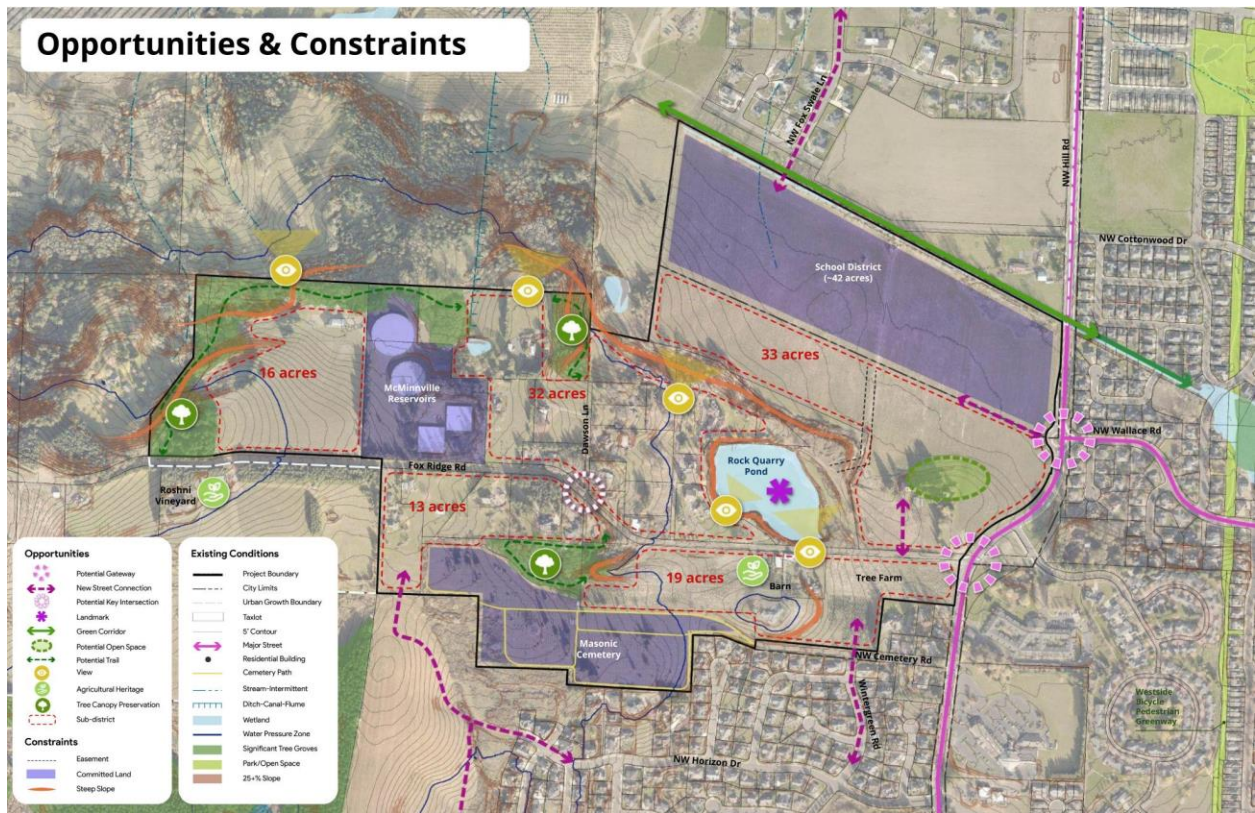

Figure 8. Opportunities and Constraints Diagram

Part 3: Community Engagement and Plan Development

Methods of Engagement and Community Input

In addition to conducting a document review and evaluation of existing conditions for the study area, the area planning process included several methods of community engagement for input and feedback to develop the goals and policies of the Fox Ridge Road Area Plan. Community engagement involved remote interviews with stakeholders, an online survey, design workshops, and public comments at Project Advisory Committee meetings and work sessions with Planning Commission and City Council. These opportunities for engagement were promoted through social media and newspaper ads, on the City website, and a City outreach booth, and updates for further involvement were provided at each of these meetings.

Stakeholder Interviews

Interviews with key stakeholders were conducted early in the area planning process to gather insight on the study area and receive initial comments on existing conditions, community features, and any current or future development plans. These interviews included private property owners, developers, and representatives from the McMinnville School District, McMinnville Water and Light, and the Oregon Department of Fish and Wildlife. These interviews provided future considerations to be accounted for within the area plan, stakeholders expectations for future development, expected services needed to support future development within the area plan boundary, connections to committed land uses, and the future planning of sensitive areas.

Online Survey

To receive a wide range of input from the Fox Ridge Road neighborhood and surrounding community, an online survey was available for one month between March 10 to April 10, 2023. The survey questions aimed to gauge the familiarity of respondents to the Fox Ridge Road area, and what the community's vision for the future of the Area Plan appeared to be. A total of 147 responses were submitted, many of which emphasized park, trails, and open space, preserving some aspect of the existing rural landscape, and helped identify key assets such as the Rock Quarry Pond, Masonic Cemetery, and scenic views of the area. There were diverse responses regarding housing density and affordability. Please see Appendix A for the summary of the survey results and responses.



Community Design Workshops

A total of two community design workshops were held to engage stakeholders, City staff, and citizens in interactive design sessions around the potential development scenarios for the Fox Ridge Road area. The intent of these workshops was to collaboratively develop a framework for future growth. The first workshop focused on gathering input to develop three distinct development scenarios for the area, with the consideration of land use, urban design, connectivity, access, infrastructure, and stakeholder concerns. The second workshop focused on parks, trails, and connectivity, and explored design concepts for the parks and trails, as well as the bike and pedestrian connections between these spaces. Please see Appendix B for summaries from both community design workshops.

DRAFT

Project Advisory Committee Meetings

The Fox Ridge Road Project Advisory Committee (PAC) was formed at the beginning of the area planning process and has held six meetings over the course of one year starting on December 1, 2022. These meetings reviewed project goals, findings of analyses and reports that were developed, outcomes of the community design workshops and online survey, and the development scenarios that were created as a result of those workshops. Committee members provided their input on these items and helped refine the resulting land use concepts to create a preferred land use concept plan. The Project Advisory Committee also identified key goals for the community and provided valuable feedback on the goals and policies that were created based on public engagement, stakeholder concerns, and the regulatory context and planning framework required to be met by the area plan. The area planning process has been guided by the Project Advisory Committee, representing the interests of the community, and creating the final vision for the Fox Ridge Road Area Plan.



Plan Development and Alternatives

As a result of the community engagement efforts, three land use concept “alternatives” were developed that each highlighted different priorities and elements required within the plan. Ultimately, each alternative was evaluated against the regulatory framework for the Fox Ridge Road Area Plan to identify the plan highlights and deficiencies. The alternatives, along with their findings, were presented to the PAC for review and feedback to create one preferred land use concept that accurately captured regulatory and planning requirements, as well as the vision of the community. Input from the community that influenced the development of the preferred land use alternative also informed creation of goals and policies for the plan, which captured the following comments and concerns:

- The desire for **parks, trails, and open spaces** throughout the planning area.
- The preservation of **scenic views** with opportunities for viewpoints along proposed trails.
- Conserving community features such as the **rock quarry pond, masonic cemetery, and tree farms**.
- Ensuring **neighborhood-serving retail** in new commercial areas.
- Consideration of development impacts on **nature, wildlife, and mature tree stands**.
- Potential **traffic impacts** with new development and higher density.
- Concerns regarding **design and aesthetics** of new developments.
- Providing pedestrian and bicycle pathways for **walkability, access, and safety**.

The draft preferred land use concept was presented to the Planning Commission and City Council at a joint work session held on October 18, 2023, for discussion. Input received from the work session helped further refine the concept for the final Area Plan Map (see Figure 9).

Market Analysis

A market and development analysis was conducted that focused on identifying the most feasible development types for commercial and higher density residential land in the Neighborhood Activity Center. The report provides market overviews, generates reliable assumptions with respect to achievable pricing and absorption, and outlines feasible uses, scale, and development forms within the Neighborhood Activity Center. The residential analysis provided focuses on high-density uses and evaluates the rental and ownership housing separately. The analysis indicates that there is adequate market support for rental apartments, rental townhomes, ownership townhomes, and commercial space in the Fox Ridge Road Neighborhood Activity Center. The analysis also provides further detail on the development types that would be feasible in this area, the potential for mixed-use projects, as well as the location for commercial and high-density residential uses. The full market analysis is included in Appendix D.

High-Density Residential

Demand for rental housing increased notably during the last decade. With a reduced supply of single-dwelling rentals, markets saw strong gain in apartment demand over this period of time. According to the market analysis, McMinnville has not seen the same increase in apartment construction as most other parts of the region. With limited new supply, apartment properties in McMinnville have seen a decline in vacancy rates over the past 10 years, and the current low vacancy rates indicate considerable pent-up demand. One of the factors that has likely sustained strong occupancy in McMinnville is relatively affordable rent levels, which may also have deterred new development. Based on the analysis, rental apartments are recommended closest to the commercial section, which is consistent with the MGMUP. Rental housing tends to benefit more from that proximity, and the location will provide access to further amenities such as nearby park/green space and access to neighborhood-serving commercial retail.

Commercial Space

Based on the analysis, commercial activity in the NAC will depend on good exposure to auto traffic and will therefore need a location on the major Hill Road intersections, either at Wallace Road or Fox Ridge Road. Assuming the future development of the School District site the Wallace Road intersection provides the strongest exposure, positioning the commercial components to capture demand from residents east of NW Hill Road in addition to Fox Ridge Road Area residents.

Transportation and Traffic Impact Analysis

An existing and future analysis of traffic conditions was conducted with 20-year forecasting for future growth assumptions. Intersection traffic operations were analyzed for the weekday AM and PM peak hours under the existing conditions and future 2041 conditions to evaluate if the study area intersections meet the desired performance levels of the City. The analysis includes a future 20-year no-build and build analysis and identifies the transportation infrastructure needs for the Fox Ridge Road study area based on the Preferred Land Use Concept. The full traffic study is included in Appendix E.

Based on these land use assumptions, two intersections are estimated to fail to meet the City's vehicle operating standard in 2041. The suggested mitigation measures include:

- **NW Hill Road at Fox Ridge Road:** Install a single-lane roundabout or traffic signal.
- **NW Hill Road at 2nd Street:** Install a single-lane roundabout or traffic signal.

DRAFT

Bicycle, Pedestrian, and Transit Needs

Conditions for bicyclists, pedestrians, and transit needs were considered within the traffic analysis for the study area. NW Hill Road between Baker Creek Road and 2nd Street had recently been reconstructed with on-street bike lanes, gutter, curb, sidewalks, and a center turn lane/raised median since the McMinnville Transportation Systems Plan (TSP) was adopted in 2010. There are still gaps in the sidewalk along the west side of the road that is anticipated to be filled in as annexation and development occurs. The segment of NW Hill Road between 2nd Street and Alexandria Street does not have any sidewalks, curb, gutter, or on-street bike lanes. Although, there are existing wide paved shoulders for bikes within this segment. There are no local transit routes that stop or travel along NW Hill Road. The City is working with Yamhill County Transit to eventually extend services to residential and commercial locations along NW Hill Road as the Fox Ridge Road Area develops. As the Neighborhood Activity Center develops and additional medium-density and high-density residential units are developed, demand for public transportation will increase.

Priority TSP Projects

The City is also working on updating their TSP which will maintain standards for pedestrian and bike facilities and identify where improvements shall be made throughout the City and including within the Fox Ridge Road Area. In their current McMinnville TSP (2010), the priority vehicle, pedestrian, and bike projects that are applicable to the Fox Ridge Road study area include the following:

- Compete Streets Update – NW Hill Road South (between 2nd Street and Alexandria Street) includes addition of pedestrian sidewalks and on-street bicycle lanes.
- Installation of a roundabout or traffic signal at NW Hill Road and 2nd Street. Based on the recent traffic analysis performed, a single-lane roundabout was evaluated at this location but was found to require dedicated southbound and westbound right turn lanes to operate adequately, which would also require more right-of-way than a traffic signal with dedicated left turn lanes. Although a single-lane roundabout was evaluated to function at this intersection, a signalized improvement could be equally as effective in managing traffic.

Implications for the Area Plan

The Fox Ridge Road Area Plan anticipates the future urbanization and development of the study area where existing low-density residential neighborhoods are gradually redeveloped with infill projects that comply with the MGMUP Framework Plan. This includes higher density housing developments, neighborhood serving commercial retail, parks, trails, pedestrian connections, and street improvements. As the plan is realized, new developments will require additional services and improved infrastructure to support growth within the study area. The Fox Ridge Road Area Plan provides specific direction on the land use and design for future development within the study area as properties are annexed and developed.

DRAFT

Part 4: Fox Ridge Road Area Plan

This chapter presents the final plan and land use concepts that will guide future development and planning decisions within the Fox Ridge Road Area. This Area Plan has been created by the community through design workshops, online survey responses, Project Advisory Committee meetings, and public work sessions. This process of community engagement helped develop the initial land use concept alternatives and form the goals and policies for the Area Plan. The initial draft land use concepts were ultimately refined by the City's Project Management Team, Planning Commission and City Council through the area planning process. The Fox Ridge Road Area Plan's final preferred land use concept achieves the community's vision and goals while fulfilling the City's model for traditional neighborhoods and the Great Neighborhood Principles.

The Plan Narrative

Land Use and Design

The Fox Ridge Road Area Plan's developed land uses are mapped in the Area Plan Map (see Figure 9) and includes all elements designated within the Framework Plan. The Neighborhood Activity Center is located along NW Hill Road at the Wallace Road intersection with commercial mixed-use and a park plaza at the core of the activity center. High-density and medium-density residential land uses are located directly adjacent to the neighborhood-serving commercial uses and surrounds the park plaza, and low-density residential land uses are located outside of the activity center where topography exhibits steeper slopes. A neighborhood park has been identified south of Fox Ridge Road and is located within a ½-mile distance from all residences within the Area Plan. Key community features have been identified including the Rock Quarry Pond, School District site, and the McMinnville Reservoir property. The remaining land to the west and the ridgeline areas along the northern boundary of the study area are allocated as a Natural Resource Park, which will also serve to protect existing natural resources and take advantage of the area's scenic viewpoints. Greenways and secondary trails connect the entire study area to adjacent neighborhoods, and potential street connections have been identified throughout the Area Plan.

The Fox Ridge Road Area Plan considers local design considerations that build on the Great Neighborhood Principles and their related plan policies. These include:

- Protection of the Rock Quarry Pond and Masonic Cemetery as community features.
- Coordination with the School District site and the Neighborhood Activity Center.
- Creating walkable and neighborhood-serving mixed-use commercial development.
- Connecting the proposed park systems for accessibility to all residents in the area.
- Emphasizing pedestrian and bicycle safety and access through frontage road improvements, greenways, and trail systems.

Key features of the Area Plan include:

- **Mixed-Use Commercial.** Within the focus area of the Neighborhood Activity Center, mixed-use commercial land use has been designated to provide flexibility in future development. This area may be developed with ground floor commercial uses and residential units or office space above ground. The location of the mixed-use commercial land use is intended for neighborhood serving retail development to provide goods and services to the residents of the Fox Ridge Road Area.
- **Higher Density Residential.** Designation of medium-density and high-density residential units maximizes opportunities for new housing development and allows for a variety of diverse housing options. The location of these higher density residential land uses is directly adjacent to the designated mixed-use commercial area, creating walkable and accessible neighborhoods.

DRAFT

- **Neighborhood Park.** The neighborhood park provides opportunities for active and passive recreation that is accessible to all residents in the study area. The neighborhood park is centrally located within ½-mile distance from all residences and exceeds the minimum target acreage.
- **Natural Resource Park.** A natural resource park has been identified at the west end of the study area, and along the northern boundary following the existing ridgeline. The designation of these lands as a natural resource park preserves the existing natural features while providing opportunities for both active and passive recreation. The natural resource park includes large open green spaces as well as proposed trails along the northern ridgeline that take advantage of the scenic viewpoints of the study area.
- **Greenway and Trail System.** Identified greenways connects NW Hill Road through the study area via Fox Ridge Road and provides direct connections north to the Neighborhood Activity Center into the School District site. The greenway system also provides connections to the natural resource park, with secondary trails that ties the study area together. This creates a “looped” and well-connected pedestrian network of primary trail/greenways and secondary trails.
- **Natural Feature Preservation.** The study area contains several stands of mature trees that provides habitat for protected avian species, the Rock Quarry Pond that stores runoff water used for off-site irrigation, and many opportunities for scenic vistas along the northern ridgeline. These areas of existing natural features are preserved as designated park land, greenways, or trails.
- **Street Connections.** Potential street connections connect the study area to the surrounding neighborhoods and their existing street systems.

Neighborhood Activity Center

The MGMUP Framework Plan calls for a partial Neighborhood Activity Center along the area’s Hill Road frontage between the Wallace Road roundabout and the intersection of Fox Ridge Road. The proposed NAC is located within the northeast corner of the study area, west of NW Hill Road. The plan highlights a distinct Focus Area of the NAC, where mixed-use commercial and a park/plaza has been located. Surrounding this area is the Support Area, where high-density residential exists and decreases in density moving away from the focus area.

Focus Area

Mixed-Use Commercial

The location of the NAC focus area is well-positioned for mixed-use commercial development, specifically for neighborhood-serving retail. The location of the mixed-use commercial land use benefits from its proximity to the proposed future High School Site, adjacency to NW Hill Road which provides exposure and access, and distance from existing and proposed residential areas. The mixed-use commercial is anticipated to provide for ground floor retail services with upper floor residential housing or professional office use. The land use designation as a mixed-use allows for flexibility in future development, depending on market conditions and feasibility. This may be high-density housing with ground floor commercial, or smaller-scale commercial with second-story offices. Commercial uses will provide essential services for the neighborhood in one convenient location that is accessible in a single stop.

Park/Plaza

Centered within the NAC focus area, the park/plaza location provides a central location for community gathering and recreation. The park/plaza may include open green space with pedestrian sidewalks, a gazebo or gathering space, park benches for seating, water fountains, and other facilities that encourages ease of

DRAFT

use. With its central location and open space, temporary uses may be encouraged within the park/plaza such as organized events, farmers markets, art fairs, cultural performances, or other recreational clubs or activities. The park/plaza is a critical element to organize the neighborhood around both passive and active recreational opportunities, connecting the NAC with the surrounding support area.

Support Area

Residential Land Uses

High-Density Residential (HDR)

1/8-mile radius from focus area.

Surrounding the activity center are support areas that include the highest-density housing within the neighborhood. The Framework Plan calls out a target of 2 acres minimum for high-density residential area. As desired by the community, the HDR allocated within the Area Plan exceeds the Framework Plan target with a total of 4.4 acres designated for future high-density residential development. All HDR areas are located just outside of the focus area, surrounding the southern boundary of the NAC park/plaza north of Fox Ridge Road. This location provides direct access from HDR areas to neighborhood-serving commercial areas, the NAC park/plaza, and the high school site. Configuring all HDR north of Fox Ridge Road eliminates the need for street crossing to access the focus area and creates cohesive design opportunities for future development. Areas designated as High-Density Residential will be classified under the R-5 High-Density, Multiple-Dwelling Zone.

Medium-Density Residential (MDR)

1/4-mile radius from focus area.

Progressively decreasing in density outwards, the medium-density residential areas are also located within the support area. The Framework Plan identifies a target of 2 to 5 acres for medium-density residential area. The Area Plan maximizes density with 10.6 acres of designated land uses for future medium-density residential development. These MDR areas are located north of the focus area (adjacent to the School District site) and south of Fox Ridge Road across from the designated HDR. Areas designated as Medium-Density Residential will be classified under the R-3 Medium-Density or R-4 Medium, High-Density Zones.

Low-Density Residential (LDR)

As identified in the MGMUP, the Fox Ridge Road study area is one of the few areas planned for R-1 density. Low-density residential land uses outside of the NAC are designated in the following areas: where street facilities are limited to collectors and local streets, such as Fox Ridge Road which is classified as a local street within the TSP; where there are development limitations due to topography, soil characteristics, or drainage; and within areas that have a limited capacity for development in terms of facilities and services such as sewer, water, drainage, schools, police, and fire. As described in the existing conditions section of this plan, much of the Fox Ridge Road study area exhibits topographic constraints, natural hazard areas, and existing limitations to capacity such as sewer and water services. These constrained areas have been identified for low-density residential development. Areas designated as Low-Density Residential will be classified under either the R-1 or R-2 Low-Density Zones.

Connectivity

The focus area and support areas are connected by proposed street connections and pedestrian greenways. The greenways are a system of primary trails that connect the NAC to the rest of the study area, creating safe and accessible means of pedestrian and bicycle travel without having to rely on automobiles. Secondary trails create additional connections between greenways and other key features such as the various parks designated throughout the study area and all of the low-density residential designated west of the activity center. These connections emphasize walkability, scale, and safety within the activity center and ensure that residents throughout the Fox Ridge Road Area have direct access to the activity center.

DRAFT

Types of Land Uses

The market analysis prepared for the Fox Ridge Road study area provides suggestions for land uses that may be feasible for future development. The following are potential uses based on the market analysis and discussion with the community that fulfill the vision for the Fox Ridge Road Area Plan:

Mixed-Use Commercial

- Neighborhood grocery store or market
- Pharmacy or drug store
- Bakery or coffee shop
- Neighborhood services or retail
- Neighborhood restaurant or pub
- Professional office space
- Upper story housing (commercial on ground floor)

Residential

- High-density housing (R-5 zone)
- Medium-density housing (R-3 and R-4 zones)
- Low-density housing (R-1 and R-2 zones)

Public/Institutional

- Neighborhood park or plaza
- Public market
- Daycare facility
- Schools

Land uses that should be avoided include uses that are considered noxious when located next to a residential neighborhood, large retailers or discount stores, auto-oriented businesses, warehousing, storage, or heavy manufacturing. These types of uses do not compliment a traditional neighborhood, which moves away from automobile dependency and relies on neighborhood-oriented retail services that encourages walkability and human scale design.



Aerial perspective of the Neighborhood Activity Center site looking west of NW Hill Road.

DRAFT

Parks and Public Facilities

Neighborhood Park

To provide recreational opportunities that support the residential land uses, a neighborhood park has been designated within the Fox Ridge Road Area that exceeds both the Framework Plan target of 3 to 5 acres and the Parks Master Plan facility requirements of 5 to 12 acres. The designated neighborhood park is 8.7 acres total, which also includes a buffer between the Masonic Cemetery along the southern boundary of park. The buffer acts as a barrier for the Masonic Cemetery from active recreational uses that may occur within the park such as active sports, large gatherings, or other programmed events. The neighborhood park is centrally located within a ½ mile distance from all residences in the study area and contains pedestrian trail connections that link the park to surrounding uses and areas. A primary greenway provides a direct connection from the NAC to the neighborhood park via Fox Ridge Road, and secondary trails further connect the park to adjacent low-density residential areas and other neighborhoods such as the Hillcrest Master Plan south of the study area. The location of the neighborhood park serves to protect existing natural resources such as the dense stands of mature significant trees within the designated park area.

Natural Resource Park

The Fox Ridge Road Area is defined by its scenic views and challenging topography. Due to the existing natural and geographic features of the study area, a natural resource park is included that takes advantage of the topography and existing natural resources within the westernmost areas and along the northern boundary. The natural resource park preserves the natural landscape of these more challenging areas while providing opportunities for scenic vistas along the northern ridge. The total area for the park is comprised of roughly 29.5 acres, which is connected to the study area via greenways and secondary trails. The greenway system along Fox Ridge Road encourages pedestrian travel west through the natural resource park heading north before transitioning to the secondary trail system that provides additional access along the northern ridge with demonstrated viewpoints. The natural resource park also further serves to protect the area's significant tree groves, which provide habitat to several protected avian species.

Special Use Park / Rock Quarry Pond

Throughout the community engagement process, the rock quarry pond was consistently identified as a key feature of the study area. Conveniently located directly east of the NAC abutting the HDR land use, the plan designates the rock quarry pond as a Special Use Park to be developed as a recreational site or natural resource with opportunities for pedestrian access. This future improvement may include pedestrian pathways around the pond with bench seating that takes advantage of the views. The rock quarry is not only a significant community feature, but actively provides irrigation off-site as it is continuously filled from uphill water runoff. Future stormwater master planning and subsequent development surrounding the rock quarry pond should consider the continuous fill level of the pond. Development of the Special Use Park will need to design stormwater management to ensure the rock quarry pond remains as a pond.

Primary Trail / Greenway

The greenway system serves to protect the natural resources of the study area and preserve wildlife habitats. Greenways supports outdoor recreation and may offer trail-oriented features such as benches for seating, restrooms, bike racks or trash enclosures. These primary trails also provide direction connections through the study area by providing multi-use pathways for pedestrians and alternative modes of transportation. A major section of the greenway system is along Fox Ridge Road, which will buffer the primary multi-use trail from the street for safe and accessible routes of transportation. These greenways also create buffers between uses, such as between the LDR and MDR that is located within the NAC. Designated greenways create connectivity between all proposed parks and direct connections from the School District site, through the NAC, along Fox Ridge Road, and loops back around with secondary trails.

DRAFT

Secondary Trail

Secondary trails act as connectors to provide a public access route for commuting and trail oriented recreational activities such as walking or biking. These trails typically include sidewalks and can be designed as multi-use trails and paths with designated bikeways. Within the Fox Ridge Road Area, some sections of trails may be developed more naturalistic around sensitive natural resource areas that require preservation. Secondary trails will help reduce auto-dependency by connecting community facilities and services to residential neighborhoods. They also serve to provide shorter relief points from the looped trail system for complete access to all sections throughout the study area.

Infrastructure and Other Utilities

Street Connections

Potential street connections and access points are identified throughout the Area Plan Map. These points of connection are based on the City's minimum block length standard and suggests connections where future developments may consider local street access. Future development will dictate the location of developable street connections, which will require compliance with the City's development standards.

Existing Public / Committed Use

McMinnville Reservoirs

McMinnville Water and Light owns the 13-acre property that houses four above-ground water reservoirs.

Masonic Cemetery

Identified as a key community feature, the Masonic Cemetery occupies nearly 70 percent of the southern boundary with a 21-acre site. The neighborhood park abuts the northern boundary of the cemetery; however, a natural buffer has been allocated along this boundary between the two land uses.

The Vision, Goals, and Policies

The Fox Ridge Road area is a beautiful naturalistic landscape with rolling hills that reflects the character and connection of a small-town community. With its breathtaking vistas, historical features, and opportunities for future neighborhood development, this once sprawling area highlights the goals of McMinnville's Great Neighborhood Principles in its envisioned land use, development, design, preservation, and connectivity. The following are goals for the Fox Ridge Road area that reflect the desires and values of the community with specific policies provided under each goal to guide development and future planning decisions:

GOAL 1: COHESIVE LAND USE PLAN – Ensure future development reinforces the Framework Plan and Great Neighborhood Principles with a connected Neighborhood Activity Center.

The plan area contains existing low-density residential development. This plan aims to provide a mix of land uses that support each other, including a variety of housing development types to support single-dwelling and multi-dwelling development, and neighborhood serving commercial and office developments.

Policies:

- 1. New commercial developments should be designed to be at a walkable, human scale and for ease of use by all ages and abilities.*
- 2. Encourage a diversity of future housing forms, types, and designs that respect the existing character of the Fox Ridge Road plan area including both single-dwelling and multi-dwelling development.*
- 3. New developments should promote inclusion and interaction within the right-of-way.*

DRAFT

4. *Encourage neighborhood serving, oriented, and scaled commercial uses that is easily accessible to residents within the Neighborhood Activity Center.*
5. *Limit the location of any commercially zoned land to the Neighborhood Activity Center.*

GOAL 2: OPEN GREEN SPACES – Create well programmed and connected parks, trails, and open spaces that aim to help preserve and protect existing natural resources and scenic views.

The plan area contains several natural and community resources including the Rock Quarry Pond, Masonic Cemetery, significant tree groves, and a large natural area along the northern ridge. This also includes scenic views of natural scenery and landscapes, and scenic resources such as dark night skies that may be impacted by light pollution and design. This plan aims to preserve, protect, and enhance these identified resources while promoting both passive and active recreational opportunities that are connected throughout the area.

Policies:

1. *The built environment will be designed to provide and protect scenic views from the area.*
2. *The Rock Quarry Pond should be protected and enhanced as a Special Use Park with public access.*
3. *The Masonic Cemetery should be protected and respected by future developments.*
4. *Significant natural and community features should be inventoried and protected to the extent fullest.*
5. *Locate and acquire areas within the plan area that have been identified as open space for the development of parks, trail corridors, and open green spaces.*

GOAL 3: AESTHETICS AND DESIGN – Encourage well designed and aesthetically pleasing developments that help meet land use goals while preserving the character of the area.

The plan area contains existing rural residential developments at very low densities with small-town design characteristics. This plan aims to preserve the small-town character of the area by allowing development for future growth which reflects, preserves, and supports the existing character of McMinnville. Alternative proposals to design will be evaluated based on compatibility with the plan area.

Policies:

1. *The existing small-town character of the Fox Ridge Road plan area should be considered when designing residential, commercial, or institutional developments within the plan area.*
2. *Require future landscaping within the area to include native landscape plantings with seasonal variation and tree plantings that include deciduous trees to provide shade for the public streets.*
3. *Adopt design guidelines for the Neighborhood Activity Center that complement the small-town character of the Fox Ridge Road plan area and the City of McMinnville.*

GOAL 4: TRANSPORTATION – Enhance local connectivity and pedestrian accessibility throughout the area.

This plan aims to create a connected transportation and pedestrian network that serves the Fox Ridge Road plan area and its surrounding neighborhoods, ensuring safe access for residents of all ages and abilities.

Policies:

1. *The Fox Ridge Road Area will have safe shared pedestrian and bicycle routes for residents.*

DRAFT

2. *Planned multi-use paths should be at least 10 to 12 feet wide for utility purposes.*
3. *New street connections should connect to the existing local street grid consistent with the Local Street Connectivity map and comply with the Transportation System Plan standards.*

GOAL 5: NATURAL FEATURES AND HAZARD AREAS – Protect wildlife species, significant tree stands, and hazard areas that have been identified for mitigation or protection.

The plan area contains identified hazard areas for both mitigation and protection, as well as natural features. This plan is designed with consideration to both natural features and hazard areas. The Area Plan will be coordinated with future Natural Features and Hazards planning as part of implementation.

Policies:

1. *The plan should be coordinated with Natural Hazards and Natural Features Planning.*
2. *The plans should seek to protect areas of wildlife habitat.*
3. *The plan should be coordinated with planning for natural hazards to protect life and property from natural hazards.*
4. *Plan for the “ridgeline” natural areas to trails for connectivity or passive and active recreational opportunities.*
5. *Public improvements and private development should strive to protect existing significant tree stands and individual mature significant trees.*

Great Neighborhood Principles

In April 2019, the City of McMinnville adopted the Great Neighborhood Principles into the City’s Comprehensive Plan. Their purpose is to guide the land use patterns, design, and development of the places that McMinnville citizens live, work, and play. These 13 principles are listed below. Under each principle are specific policies that detail how these principles are expected to be expressed in a site and context-specific way within the Fox Ridge Road Area Plan:

1. *Natural Feature Preservation*
 - Protect the Rock Quarry Pond and Masonic Cemetery.
 - Protect existing significant tree stands and mature significant trees.
 - Protect riparian corridors and wildlife species of concern.
2. *Scenic Views*
 - Provide viewpoints and protect scenic vistas along the northern ridge of the plan area.
 - Gathering spaces will be designed to incorporate natural areas and scenic views.
 - Orient streets and open spaces towards scenic views.
3. *Parks and Open Spaces*
 - Protect existing natural resources in open spaces.
 - Create new gathering spaces within the proposed neighborhood.
 - Provide a nature-based community park.
 - Provide an open space park plaza within the Neighborhood Activity Center.
 - Provide a neighborhood park within ½ mile of all residences within the neighborhood.

DRAFT

4. *Pedestrian Friendly*
 - Provide a trail system and pedestrian corridors that provide connectivity throughout the plan area and safe access to the Neighborhood Activity Center.
 - Incorporate shade trees along pedestrian corridors.
5. *Bike Friendly*
 - Provide safe routes for residents and cyclists.
 - Utilize connected primary greenway system.
6. *Connected Streets*
 - Connect local street systems within Neighborhood Activity Center and School District site.
 - Connect to existing local street grid in the Fox Ridge Road plan area.
 - Improve Fox Ridge Road and local streets to better serve the plan area.
7. *Accessibility*
 - Design new developments with pedestrian corridors for ease of use by all ages and abilities.
 - Create connected and accessible secondary trail loops throughout the plan area.
8. *Human Scale Design*
 - Design based on small-town character—porches, balconies, prioritize outdoor and open spaces.
 - Promote inclusion and interaction within the right-of-way.
 - Design commercial uses to typical human scale.
 - Encourage shorter block lengths within new developments.
 - The public and private areas between land uses in the focus area should be intentionally designed to provide pleasant places for pedestrian and human interaction ensuring vehicular use and parking lots do not dominate street edges and park and common area interfaces.
9. *Mix of Activities*
 - Design the Neighborhood Activity Center to provide mixed-use developments where feasible.
 - Encourage neighborhood serving commercial and institutional uses easily accessible to residents.
10. *Urban-Rural Interface*
 - Preserve small-town character in development and design.
 - Consider existing agriculture and respect this heritage through careful transitions.
11. *Housing for Diverse Incomes and Generations*
 - Allow for a mix of housing types that serve a variety of household incomes.
12. *Housing Variety*
 - Encourage a diversity of housing forms and types for future housing developments that reflects the existing character of the plan area.
13. *Unique and Integrated Design Elements*
 - Unique public art, public furnishing, and design elements should be incorporated into public places, parks, and commercial areas.

DRAFT

Neighborhood Activity Center – Land Uses

Types of Residential Housing



Mixed-Use Commercial



DRAFT

Potential Features for Neighborhood Parks



Greenways and Shared Use Paths

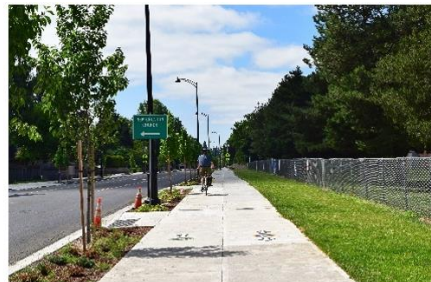

DRAFT

Trails and Natural Areas



Connecting Open Spaces



DRAFT

Relating Land Uses



The Area Plan Map

FINAL Preferred Land Use Concept

This concept maximizes capacity on the eastern and northern portions of the planning area, where the land is generally flatter, less constrained, and has closer access to NW Hill and Wallace Roads.

Parks and open spaces are distributed throughout the planning area with greenway connections, including those along the northern boundary, and parallel to Fox Ridge Road.

High Density: 4.4 ac
Framework Plan target: 2 acres

Medium Density: 10.6 ac
Framework Plan target: 2-5 acres

Low Density: 68.1 ac

Commercial: 4.9 ac
Framework Plan target: 1-2 acres

Neighborhood Park + Buffer: 8.7 ac
Framework Plan target: 3-5 acres
Parks Master Plan target: 5-13 acres

Natural Resource Park: 29.5 ac
Framework Plan target: unspecified

Special Use Park: 12.6 ac

NAC Park / Plaza: 5.0 ac

Greenway Area (between bldgs): 3.0 ac

Existing Public / Committed Use: 72.5 ac

Neighborhood Activity Center (NAC):
Shown within dashed white circles.

Note: Acreage is reported as gross and does not assume any rights-of-way deductions.

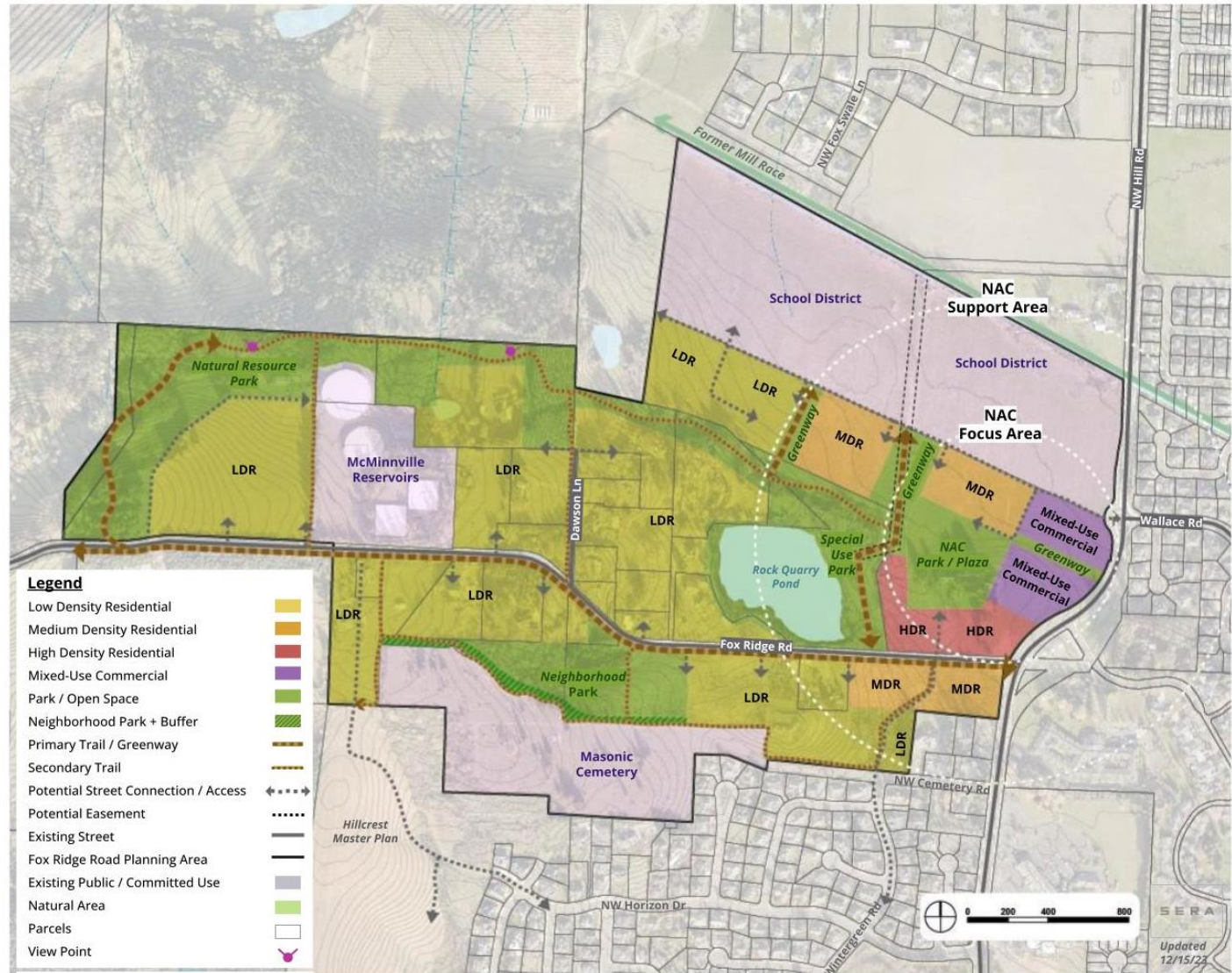

Figure 9. Preferred Land Use Concept.

DRAFT

Part 5: Implementation

Overview

As required by the area planning chapter of McMinnville’s Municipal Code, the Fox Ridge Road Area Plan reflects the long-range planning efforts intended to determine land use regulations, transportation and infrastructure plans, and community goals within the study area. This section responds to policies and regulations from McMinnville’s Comprehensive Plan, Development Code, Framework Plan, along with area and site-specific conditions. The following sections summarize the amendments that will be the primary implementation measures for the Fox Ridge Road Area Plan.

Land Use

The land use concept plan component of the plan will guide future Master Plans for properties as property owners pursue annexation and development. The Fox Ridge Road Area Plan includes a partial Neighborhood Activity Center, with a focus area and support area. Comprehensive Plan policies in Section 187.95 of the Comprehensive Plan apply to Neighborhood Activity Centers and will need to be addressed.

Water

There are three different water pressure zones with the Fox Ridge Road area, corresponding to different elevation contour bands.

- **Zone 1.** Zone 1 is currently serviceable.
- **Zone 2.** In the near-term, new pump station facilities will be needed to serve properties in Zone 2 in the Fox Ridge Road area and adjacent properties to the south which are already in City limits, which will need resolution of funding and allocation of those costs. In the longer-term, Zone 2 is proposed to be served with a new reservoir to be located west of the study area.
- **Zone 3.** A portion of the Fox Ridge Road Area located west of the reservoir site is above Zone 2 and would require Zone 3 facilities to serve. This will need to be addressed with the Water Distribution Plan update. Due to the limited acreage and lack of other UGB properties in Zone 3, an interim solution may be necessary to service that property, subject to cost feasibility analysis.

Sanitary Sewer

- There are some downstream capacity considerations in the Michelbook basin to the east and the Cozine basin to the south. The Wastewater Conveyance Plan update will need to consider capacity improvements in these basins.
- In conjunction with a requested annexation and development proposal, a property owner may need to request a model run of the City’s sanitary sewer model and may need to upsize certain downstream pipe segments prior to or concurrent with development.
- Sanitary sewer facilities are most efficiently provided with gravity flow rather than pump stations. With the existing topography and top-of-ridge location of Fox Ridge Road, slopes in the areas, and parcelization, there should be consideration of where sanitary sewer can be extended from higher elevation areas to and through lower elevation areas to enable gravity sewer. This should generally be provided in public street right-of-way; however, where topography limits street connections, consideration should also be given to provisions of facilities along public, open space, and/or trail corridors to provide for gravity sanitary sewer alignment between and connecting to public street rights-of-way.

DRAFT

Stormwater

- In conjunction with a requested annexation and development proposal, a property owner will be subject to applicable state drainage law consistent with City policy. Due to soil conditions, new developments may be required to provide detention to offset new impervious area so the development doesn't increase downstream runoff flows.
- Forthcoming stormwater planning work may consider opportunities for fewer, larger detention facilities.

Transportation

- The size and location of the study area does not necessitate new collector or arterial streets through the area. Traffic within the study area will be predominantly local residential traffic.
- Within the study area, there are opportunities for good local street connectivity within the larger properties. Areas that are already parcelized and developed may limit opportunities for internal street connectivity. There may be limitations on connectivity between some of the higher elevation areas and lower elevation areas due to topography. However, there may be opportunities for trail connectivity in those areas where street connections may be infeasible.
- Due to the location at the edge of the UGB and the presence of the cemetery, there are limited opportunities for street connectivity between the Fox Ridge Road Area and adjacent lands. However, there are opportunities for local street connectivity to City streets to the south, near the east side at Wintergreen Drive and near the west side at the future extension of the street in the Hillcrest Planned Development.
- The study area intersections are currently operating within the City's performance standards for peak hour traffic.
- For future year 2041 conditions, the traffic analysis considered not only assumptions for "build-out" of the Fox Ridge Road study area, but also assumed build-out of other lands added to the UGB (including the southwest area) and other undeveloped sites in the vicinity including the Baker Creek North Mixed Use site and the two sites on Hill Road owned by the School District assumed for future school development.
- The forthcoming Transportation System Plan (TSP) update will include analysis of the network needs including all new UGB areas. Based on the Fox Ridge Road Area Plan traffic analysis, study area intersections will meet the City's performance standard in the future year or are already identified for intersection improvements in the TSP. The one exception is Fox Ridge Road and Hill Road. The TSP update will need to evaluate if and when intersection improvements will be needed at this location. Options may range from separating left and right turn lanes off Fox Ridge Road onto Hill Road or other intersection improvement alternatives.
- The Fox Ridge Road Area Plan includes a preference for future improvements to Fox Ridge Road to be designed to a street standard that would have a separated multi-use path for bicycles and pedestrians, rather than a typical street section.

Natural Resources and Hazards

- In order to preserve and protect natural and community resources within the study area, such as the Rock Quarry Pond or significant tree groves, Natural Resource planning will need to be performed that inventories these resources and creates policies for protection.
- The City is currently engaged in Natural Hazards planning to identify potential areas that will require mitigation and protection from natural hazards, such as landslide areas that have been identified within the Fox Ridge Road study area. Adoption of the Natural Hazards Overlay Zone will be necessary to determine future development within these hazard areas.

DRAFT

Comprehensive Plan Amendments

The Fox Ridge Road Area Plan establishes land use, development, and transportation policies that will help the community realize their vision for future growth and urbanization of the area. The Area Plan will be adopted as a supplement to the McMinnville's Comprehensive Plan to guide future land use and development decisions, along with transportation and utility improvements. These changes to the Comprehensive Plan reflect the extensive community engagement process and land use decisions reached.

The proposed amendment to the Comprehensive Plan to include the Fox Ridge Road Area Plan will achieve the following goals:

- Preserve the natural resources within the planning area by enforcing appropriate development controls on lands with identified building constraints such as excessive slope or natural hazards.
- Preserve cultural and historical resources that provide positive impacts on the community and protect local sites that are significant to the City.
- Provide additional commercial land within the City of McMinnville to foster economic growth and ensure neighborhood-serving retail and services are accessible to the residents of Fox Ridge Road.
- Promote the development of quality, diverse, and affordable housing for all residents.
- Encourage the development of safe and efficient transportation including street improvements, complete streets, and pedestrian routes that connect the planning area.
- Provide necessary public and private facilities and utilities that help advance urban development.
- Ensure neighborhood parks, greenways, natural resource parks, trails and special use parks are connected and have minimal impact on environmentally sensitive lands.
- Encourage mixed-use developments within the Neighborhood Activity Center to create vibrant neighborhoods consistent with the Great Neighborhood Principles.

Comprehensive Plan Map

As a supplement to the Comprehensive Plan, the Fox Ridge Road Area Plan will require a map amendment that reflects the Area Plan Map (see Figure 9). Based on the vision of the community, the new Area Plan designates land uses within the Fox Ridge Road study area, currently indicated as Urban Holding (UH) on the City's Comprehensive Plan map. In order for the Fox Ridge Road Area to development consistently with the Area Plan Map, the City must update the Comprehensive Plan Land Use Map to reflect these newly designated land uses within the study area. This will change the Fox Ridge Road study area from UH to Residential, Commercial or Mixed Use Urban land uses.

Transportation System Plan

The Area Plan Map proposes potential street connections based on the City's development standards and the traffic analysis performed within the study area that anticipates future growth through 2041. In order to support these future connections, the City of McMinnville will need to update their current 2010 Transportation System Plan (TSP) to capture these improvements. These changes include improvements at key intersections to support future development within the Fox Ridge Road Area, and sidewalk or frontage improvements that enhance the safety and accessibility of pedestrian travel. Standards from the current TSP should be revised to ensure ease of multi-modal transportation. Pedestrian greenways should be required to have wider lanes for added safety, with added standards for shared use trails.

Utilities

Facilities for utilities that will encourage or support new development within the Fox Ridge Road Area will need to be considered and integrated as part of their relevant City master plans. An infrastructure funding plan should be considered to realize the vision of urbanization within the Study Area.

DRAFT

Policies

The policies developed within the Fox Ridge Road Area Plan act as a supplement to the existing Comprehensive Plan policies and support the implementation of the Area Plan. These policies are intended to aid in the implementation of the community vision and goals. Additional policies outline how the Comprehensive Plan's Great Neighborhood Principles are expected to be expressed in the future growth and development of the Fox Ridge Road Area.

Zoning Ordinance Application

The future development of the Fox Ridge Road Area will require zone changes within the study area subject to the designated land uses shown in the Area Plan Map. Land uses and development in the study area is regulated by the City's Zoning Ordinance which governs the permitted uses, density, dimensional requirements, site design, and permitting requirements for individual zoning districts. As properties annex into the City, they will be required to rezone into urban zones that fall under their designated Comprehensive Plan land use and fulfill the goals and policies of the Fox Ridge Road Area Plan.

Master Planning Process

Properties greater than 10 acres in size must undergo a Master Planning process prior to annexation or development within the City. The Master Plan must comply with the submittal requirements and review criteria outlined within the City's Zoning Ordinance. These developments must:

- Be consistent with the Framework Plan, Area Plan, and Comprehensive Plan in terms of land use, density, transportation systems and networks, and open space;
- Be suitable for the area, considering existing and planned neighborhoods, retail and employment areas, and natural resource and hazards;
- Be integrated with existing developed or planned areas;
- Meet the City's adopted Great Neighborhood Principles.

Development of Properties Less Than 10 Acres

Land less than 10 acres in size may be annexed into the city and rezoned without the adoption of a master plan, however, are subject to the comprehensive plan map amendment and zone change review processes. These developments must:

- Be consistent with the uses identified in the area plan;
- Meet the City's adopted Great Neighborhood Principles;
- Include a local street plan that complies with the Area Plan, the McMinnville TSP, and other local street block length and connectivity requirements;
- Be consistent with all other required policies and standards of the McMinnville Comprehensive Plan and Zoning Ordinance.

Neighborhood Activity Center (NAC) Overlay District

The NAC Overlay may be applied to the partial Neighborhood Activity Center, which would require less than the average acreages for each land use portion listed in the overlay zone because it is only a partial NAC. The NAC Overlay permits mixed-use developments such as ground floor commercial with above ground residential or office space. The Neighborhood Activity Center Planned Overlay enables lands designated as activity centers to develop as integrated, high-quality, mixed-use, pedestrian-oriented neighborhoods. Utilizing this district overlay will help minimize traffic congestion, suburban sprawl, infrastructure costs, and environment degradation. Specifically, the policies and procedures section of the chapter provides guidelines for Mixed Land Use that promotes easy access among store and services for pedestrians.

DRAFT

Shown on the Area Plan Map, the NAC follows the location guidelines implemented by the overlay chapter. This includes the following requirements (shown in Figure 9 as radiuses around the focus area):

- Maximum distance that nonresidential uses may radiate outwards from the center – 1/4 mile
- Maximum distance from the edge of the focus area for HDR within the support area – 1/8 mile
- Maximum distance from the edge of the focus area for MDR within the support area – 1/4 mile

By providing mixed-use developments and meeting the location requirements for high-density and medium-density housing, the NAC Overlay helps achieve accessible, attractive, and safe development.

Recommended Amendments

Design guidelines for the neighborhood commercial zone.

At the present time, McMinnville has adopted Residential Design Standards for new housing developments within the City. However, design guidelines for commercial developments have yet to be adopted. After adopting the Fox Ridge Road Area Plan, the City should work towards developing and implementing commercial design standards for the Neighborhood Commercial Zone that help achieve the goals and policies of the Area Plan and the Great Neighborhood Principles.



**City of
McMinnville**

APPENDIX A



FOX RIDGE ROAD AREA PLAN

DOCUMENT REVIEW AND EXISTING CONDITIONS REPORT
DECEMBER 2023

DOCUMENT REVIEW AND EXISTING CONDITIONS REPORT

Contents

1.0	BACKGROUND	4
2.0	PROJECT GOALS	6
3.0	EXISTING CONDITIONS	9
3.1	PROPERTY AND DEVELOPMENT PATTERNS	9
3.2	LAND USE AND ZONING	9
3.4	NATURAL FEATURES	11
3.4.1	HABITAT AND NATURAL FEATURES	11
3.4.2	HAZARDS	11
3.4.3	TOPOGRAPHY	12
3.4.4	LANDSCAPE AND VIEWS	12
3.5	INFRASTRUCTURE AND SERVICES	12
3.5.1	TRANSPORTATION	12
3.5.2	UTILITIES (WATER, SEWER, STORMWATER, AND OTHER)	14
3.5.3	COMMUNITY FACILITIES AND PROXIMITY	18
4.0	REGULATORY CONTEXT AND PLANNING FRAMEWORK	19
4.1	MCMINNVILLE GROWTH MANAGEMENT AND URBANIZATION PLAN	19
4.2	MCMINNVILLE FRAMEWORK PLAN	19
4.3	COMPREHENSIVE PLAN – VOLUME II: GOALS AND POLICIES	21
4.4	TRANSPORTATION SYSTEM PLAN AND TRANSPORTATION ISSUES	21
4.5	TRANSIT PLAN	26
4.6	MCMINNVILLE MUNICIPAL CODE	28
4.5	PLAN UPDATES	30
5.0	FINDINGS AND KEY ISSUES	30

MEMORANDUM

City of McMinnville – Fox Ridge Road Area Plan



Date: December 22, 2023
To: Tom Schauer, City of McMinnville
From: Thuy Cao, HHPR
Subject: **City of McMinnville Fox Ridge Road Area Plan**
Task 1.2: Document Review and Existing Conditions Report

INTRODUCTION AND PURPOSE OF THIS PLAN

This project will adopt an area plan for the Fox Ridge Road Area which is consistent with the Comprehensive Plan and with the Framework Plan that was adopted in 2020. Appendix G of the MGMUP provides the Framework Plan and describes the Area Planning process.

PURPOSE OF THIS DOCUMENT

Development of the Fox Ridge Road Area Plan includes consideration of technical issues and community engagement and input. This document includes a review of data and existing plans, policies, standards, and regulations that need to be considered in development of the Fox Ridge Road Area Plan. It also includes a summary of other planning documents that are in the process of being updated. The work with this area plan will also help inform coordination with those planning efforts. This document review and existing conditions report will identify issues and parameters that guide development of the plan and inform community engagement. With the community engagement efforts, valuable information about existing conditions and neighborhood assets also supplements this report.

This document also includes a discussion of the existing conditions and characteristics of the Fox Ridge Road Area to be considered in development of the plan. Existing conditions are summarized graphically in an Existing Conditions Map attached as Exhibit 1. The above information has been analyzed to identify issues affecting development of the plan. That analysis is summarized in Section 5.0 of this document and in the Opportunities and Constraints Analysis map attached as Exhibit 2.

There may also be aspects of this work that will help inform coordination with other plans which are in the process of being updated, including public facility plans, the Parks, Recreation and Open Space Master Plan, and the Transportation System Plan.

1.0 BACKGROUND

The City of McMinnville adopted the McMinnville Growth Management and Urbanization plan (MGMUP) in conjunction an amendment to its urban growth boundary (UGB). Between two phases, the MGMUP amended McMinnville’s UGB by 924 gross buildable acres. The MGMUP was originally adopted in 2003 and refined in 2005. The original UGB expansion included 1,052 acres. Of this, 259 acres was able to become part of the UGB, and the remainder was challenged on appeal. The City addressed a remand order in 2013, removing some areas from the UGB that were previously added to the UGB and approved by DLCD and LCDC in 2005. In 2020, the City added 665 gross buildable acres to the UGB as Phase 2 of the amendment, which was approved, totaling 924 gross buildable acres between Phase 1 and 2.

The original 2003 UGB amendment included all of the property currently in the Fox Ridge Road area and additional contiguous property to the north. A portion of that was subsequently removed in the 2005 refinement, which resulted in the same boundary of the Fox Ridge Road area as now exists. Part of that was subsequently removed in 2013 as a result of the appeal and remand, being added back again with the 2020 UGB amendment.

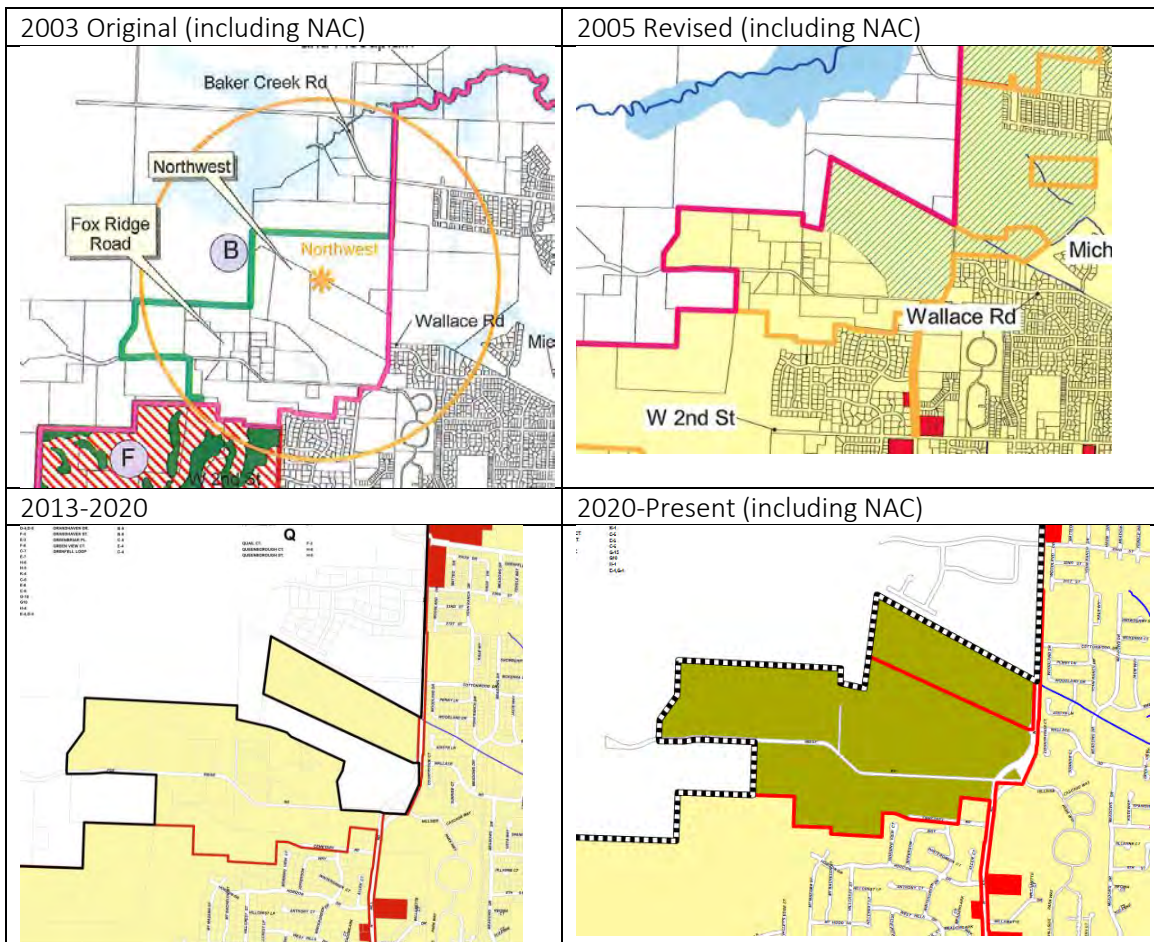

Therefore, the boundary in this area is the same in 2020 as it was in 2005, which also included planning for a portion of a Neighborhood Activity Center (NAC). Much of the public facility planning was conducted after the 2005 plan was adopted and approved by DCLD and LCDC and before the 2013 amendments in response to the remand. As a result, much of the public facility planning

which was conducted after the 2005 UGB amendment occurred before the 2013 amendment and was therefore based on the same boundary for the Fox Ridge Road area boundary that currently exists following adoption of the 2020 UGB amendment.

Most of the land added to the UGB has been placed into an Urban Holding (UH) comprehensive plan designation. All land within a UH comprehensive plan designation must undergo an area planning process prior to annexation into the city limits, rezoning, or development. The City of McMinnville has committed to investing and processing one area plan each year. The first area plan initiated by the City is the Fox Ridge Road Area Plan. The Fox Ridge Road Area is known as the area around Fox Ridge Road, as well as the property of about 41 acres in City limits owned by the School District for a future high school site (see Framework Plan). Collectively, the Fox Ridge Road study area is comprised of approximately 230 acres. With the exception of the property owned by the School District, which is in City limits, the other properties are within the UGB but outside City limits. Those properties continue to be subject to County zoning and land use regulations until property owners apply for annexation into City limits.

Fox Ridge Road Area Map



The Area Planning process and Area Plans guide future development as individual property owners within the UGB seek annexation to the City.



2.0 PROJECT GOALS

This project will adopt an area plan for the Fox Ridge Road Area which is consistent with the Comprehensive Plan and with the Framework Plan that was adopted in 2020. Appendix G of the MGMUP provides the Framework Plan and describes the Area Planning process. The Framework Plan also provides information regarding the area plans for the different areas in the UGB. It provides the following information for the Fox Ridge Road Area Plan:

The Fox Ridge Road Area Plan will primarily be housing. However the Fox Ridge Road Area Plan will include a significant land use within the site that is owned by the McMinnville School District and identified for the development of a future high school. The high school site will be within the northern portion of the Fox Ridge Road Area Plan.

The Fox Ridge Road Area Plan should also provide an opportunity for a partial or half of a Neighborhood Activity Center (NAC) along the area's Hill Road frontage between the Wallace Road roundabout and the intersection of Fox Ridge Road. This modified and reduced NAC should be approximately 5 – 10 acres, with approximately 1 - 2 acres of neighborhood serving commercial and office development, approximately 2 acres of high density residential development (R-5), and approximately 2 – 5 acres of medium density residential housing. The remainder of the residential land within Fox Ridge Road Area Plan will likely be suitable for lower density residential housing, where the lands begin to exhibit steeper slopes within the southern and western portions of the Fox Ridge Road area.

To further provide services to support this residential area and to accommodate the park land need identified in the MGMUP, the Fox Ridge Road Area Plan should incorporate one neighborhood park of approximately 3 - 5 acres in size. The neighborhood park should be placed to ensure that every residence is within a ½ mile of a neighborhood park, and due to slopes should likely be placed in the northern portion of the area. The Fox Ridge Road Area also includes several natural and geographic features that provide an excellent opportunity for a natural resource community park. Natural greenspaces or greenways should be considered that could connect the Fox Ridge Road Area to the West Hills and Redmond Hill Road area, potentially in the form of a ridgeline greenway/greenspace. A greenway/greenspace could also serve to preserve the tree stands in the Fox Ridge Road and West Hills areas that currently provide habitat for protected avian species.

Connectivity and coordination with the development of the high school site will be important in the Fox Ridge Road Area Plan. Land uses should anticipate the development of this major community feature, and land uses should transition appropriately to surrounding areas. Any trail networks considered should incorporate connectivity to the high school site. Bike and pedestrian connectivity should also be considered in the Area Plan, with consideration of connecting to the existing trails and linear parks (BPA and Westside trail systems) that are located just east within the existing UGB and may be able to be linked via Wallace Road.

The following illustrative map from the Framework Plan provides a high-level concept of these provisions:

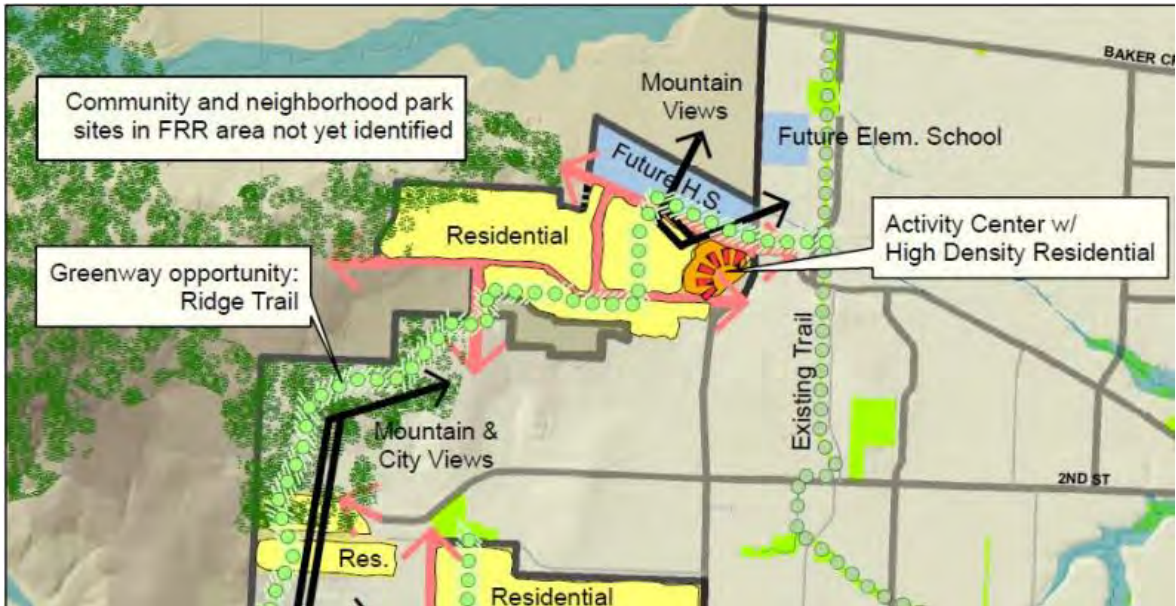

The Framework Plan also outlines the potential assignment of land needs associated with the UGB amendment to the different areas, as shown below:

Potential Assignment of Land Need:

Land Need		Southwest	Fox Ridge Road	Riverside South	Redmond Hill Road	Booth Bend Road	Riverside North
Residential							
R-5	36 acres						
Parks							
Neighborhood Park	88.11 acres						
Community Park	58.84 acres						
Greenways/Natural Areas	106.81 acres						
Schools	43 acres						
Commercial	39.3 acres						
Industrial	Surplus						

The Parks, Recreation, and Open Space Master Plan is currently in process of being updated. However, the adopted 1999 Plan defines park types, provided in Table 1, which provides information regarding typical sizes of different types of parks. Neighborhood Parks are typically 5-13 acres and Community Parks are typically larger than 12-13 acres.

Table I
PARK SYSTEM DEFINITIONS

Types of Facility	Definition	Benefits	Size Criteria	Includes	Does Not Include	Site Selection Criteria	Maintenance Level and Standard
Mini-Park/Playlot	Mini-parks, urban plazas, or playlots provide recreation opportunities for residents in areas not adequately served by neighborhood parks, such as town centers or areas of high density development.	Provides for the day-to-day recreational needs of residents; provides space for community events; balances high density development and communicates neighborhood character.	2500 square feet to 1 acre	Mini-parks or playlots may include passive or low intensity activities, such as children's play areas, pathways, multi-purpose paved areas, public art, small scale sports facilities, seating, picnic areas, community gardens, multipurpose performance space, and landscaping.	Mini-parks would generally not include high intensity sports facilities, restrooms, or off-street parking.	Mini-park sites are generally level, and the site should have physical characteristics that are appropriate for its intended use, such as well-drained soils and desirable topography. The parks should be accessible by sidewalks and/or interconnecting trails, and bike lanes or low traffic streets.	Maintenance standards will vary depending on design features. Urban plazas in high density areas should utilize NRPA Maintenance Mode I - frequent to very frequent maintenance. In low density residential areas, mini-parks should utilize NRPA Maintenance Mode III - moderate level maintenance.
Neighborhood Park	Neighborhood parks are the foundation of the parks and recreation system, providing accessible recreation and social opportunities to nearby residents. When developed to meet neighborhood recreation needs, school sites may serve as neighborhood parks.	Provides access to basic recreation activities for nearby residents of all ages; contributes to neighborhood identity.	5 to 13 acres	Neighborhood parks should include both passive and active recreation opportunities, such as children's play areas, informal sports areas, picnic facilities, public art, open turf areas, landscaping, community gardens, and pathways. Security lighting may be provided if needed.	Neighborhood parks generally do not include facilities for large groups, such as sports tournaments, off street parking, or permanent restrooms. Activities that result in overuse, noise, parking problems and congestion should not be provided.	Neighborhood parks should be located within a 1/2 mile radius of residences without crossing a major street for easy pedestrian and bicycle access. Neighborhood park sites are generally level, and sites with natural aesthetic appeal are most desirable. Locating neighborhood parks next to other park system components, such as greenways, increases use and desirability. Neighborhood parks should be located adjacent to schools and fire stations whenever possible.	Neighborhood parks should utilize NRPA Maintenance Mode III - moderate maintenance to maintain the appearance and functional use of facilities and to support public safety.
Community Park	Community parks provide a variety of active and passive recreational opportunities for all age groups. These parks are generally larger in size and serve a wider base of residents than neighborhood parks. Community parks often include developed facilities for organized group activity as well as facilities for individual and family activities.	Provides a variety of accessible recreation opportunities for all age groups; provides environmental education opportunities; serves recreation needs of families and provides opportunities for community social activities.	Greater than 12 to 13 acres	In addition to those amenities provided at neighborhood parks, community parks may include sports facilities for team play, group picnic areas, skateboard and rollerblade facilities, natural areas, botanical gardens, amphitheaters, festival space, swimming pools, interpretive facilities and community centers. Higher quality children's play areas may be provided to create a family play destination.	Facilities that do not meet recreation needs.	The site should have physical characteristics appropriate for both active and passive recreation, such as suitable soils, positive drainage, varying topography, and a variety of vegetation. A naturally attractive site character is highly desirable. Land within the flood plain should generally be considered only if facilities are to be located above the 100-year flood elevation.	Community parks should utilize NRPA Maintenance Mode II - high level maintenance - in developed portions to maintain the appearance and functional use of facilities, and to support public safety. In natural areas, NRPA Maintenance Mode IV - moderately low maintenance - should be utilized.
Linear Park	Linear parks may be developed along built or natural corridors to provide opportunities for trail-oriented activities and nature-oriented outdoor recreation. Linear parks may also provide some active and passive recreation facilities to meet neighborhood needs, especially in areas not adequately served by traditional neighborhood parks. Linear parks connect residences to major community destinations.	Protects natural resources; provides environmental education opportunities; provides opportunities for trail-oriented activities and provides access to basic recreation opportunities for nearby residents of all ages to encourage an active, healthy lifestyle, reduces automobile dependency.	Of adequate size to protect natural resources and accommodate intended uses.	Linear parks can include paved or soft-surfaced trails to accommodate jogging, biking, walking, skateboarding, dogwalking, horseback riding, canoeing or rollerblading. Active and passive recreation facilities may include small-scale sports facilities, such as basketball hoops, children's play equipment, off-leash dog areas, seating, public art, picnic tables, lighting, community gardens, and landscaping.	Recreation facilities intended for large groups, permanent restrooms, and off-street parking are generally not provided.	Although natural corridors, such as creeks and rivers are preferred, opportunities to create built corridors should be strongly encouraged. Built corridors are constructed during development or redevelopment, such as corridors created in residential subdivisions, revitalized waterfronts, abandoned railroad beds, roadway right-of-ways, boulevards, utility right-of-ways and drainage-ways. The minimum corridor width should accommodate a multi-use trail plus buffer planting (approx. 24 feet).	Linear parks should utilize NRPA Maintenance Mode II - high level maintenance - in developed portions to maintain the appearance and functional use of facilities, and to support public safety. In natural areas, NRPA Maintenance Mode IV - moderately low maintenance - should be utilized to support the natural character of the area, to maintain functional use of facilities, to provide fire and hazard mitigation, and to support public safety.
Special Use Park	A special use park is a facility for a specialized or single recreational activity, including historic and cultural sites, and recreation facilities.	Meets the recreational needs of the community; preserves historic, natural, and cultural resources; provides life-long educational opportunities and provides opportunities for community wide social events.	Size should be suitable for its use.	Historic and Cultural Sites: these may include local historical resources, arts facilities, public gardens, nature centers and amphitheaters. Recreation Facilities: many of these facilities may be located in park facilities, especially in community parks, some single purpose facilities may be freestanding, such as community centers, senior centers, theaters, golf courses, sports facilities, and aquatic parks. In addition, compatible support facilities, such as seating, interpretive signage, public art and picnic tables should be provided to increase function, use and attractiveness.	Facilities that do not meet recreation needs.	The physical site should be appropriate for the intended use. The site should be accessible by arterial and collector streets, and by public transportation and the Citywide trail system. A central location is preferred. Depending on the facility type and adjacent uses, locating special use facilities in parks or adjacent to other public facilities may be preferable for increased safety and security.	Maintenance will vary according to facility type. In general, high use may require NRPA Maintenance Mode I or II - high level maintenance to maintain functional use of facilities and support public safety.
Greenspace / Greenway	A greenspace or greenway is an area of natural quality that protects valuable natural resources and provides wildlife habitat. It also provides opportunities for nature-related outdoor recreation, such as viewing and studying nature and participating in trail activities.	Protects valuable natural resources; protects wildlife; contributes to the environmental health of the community and provides opportunities for outdoor recreation, environmental education, and trail-oriented activities.	Size should be adequate to protect the resource.	Developed features that support outdoor recreation and trail-oriented recreation may be provided, such as trails, picnic areas, benches, interpretive signs, and native landscaping. Trail-head amenities, such as small scale parking, portable restrooms, bike racks and trash enclosures, may be included.	Facilities that do not directly support outdoor recreation and trail-oriented recreation should not be included, such as ornamental plants, lawns, and active recreation facilities.	The quality of the resource is the most important determinant for site selection. In addition, sites that provide medium to high potential for environmental education, aesthetics or buffering qualities, and outdoor or trail-oriented recreation are preferred. The minimum corridor width is approximately 100 feet.	NRPA Maintenance Mode IV - moderately low maintenance - should be utilized to support the natural character of the area, to maintain functional use of facilities, to provide fire and hazard mitigation, and to support public safety.
Trails and Connectors	A public access route for commuting and trail-oriented recreational activities, includes sidewalks, bikeways, multi-use trails and paths.	Provides opportunities for trail-oriented activities; reduces auto-dependency; and connects community facilities and neighborhoods.	Width of the trail and right-of-way depends on its intended use and location.	A variety of pathways types are needed to accommodate activities, such as walking, running, biking, dogwalking, rollerblading, skateboarding, and horseback riding. Trails can be located within parks, within linear parks and greenways, or be designed as a part of the Citywide transportation system. Waterways can provide trail-like facilities for boating and canoeing. Each type of trail should be designed to safely accommodate users, and meet recognized design standards.	Active recreation facilities and facilities that do not directly support outdoor recreation and trail-oriented recreation should not be included, such as ornamental plants, lawns, and active recreation facilities.	McMinville's trail system should be coordinated with the City's Transportation Master Plan to create a pedestrian and bicycle system that connects all components of the park system and major community destinations. The trail system should provide access for people with disabilities and accommodate diverse recreational needs. Trail development is guided by site opportunities and constraints, such as pedestrian access, slope, natural resources, views and drainage.	Hard surfaced trails should utilize NRPA Maintenance Mode II - moderate level maintenance - in developed portions to maintain the appearance and functional use of facilities, and to support public safety. For soft surfaced trails , NRPA Maintenance Mode IV - moderately low maintenance - should be utilized to support the natural character of the area, to maintain functional use of facilities, to provide fire and hazard mitigation, and to support public safety.

Reference: *Park Maintenance Standards*, National Recreation and Park Association (NRPA), 1996.

3.0 EXISTING CONDITIONS

3.1 PROPERTY AND DEVELOPMENT PATTERNS

Among other data collected for UGB areas as part of the MGMUP, data was collected and analyzed for the buildable land analysis. Properties were classified as part of the analysis. With a few exceptions, most of the properties with rural-residential zoning have been divided and developed consistent with the rural residential lot sizes authorized by county zoning. Other than the School District property, the properties with AF-10 and EF-80 zoning are generally the largest properties in the area which are predominantly vacant, at approximately 33 acres and 24 acres respectively.

3.2 LAND USE AND ZONING

The Fox Ridge Road Area is within McMinnville’s Urban Growth Boundary (UGB). Most of the area is unincorporated, outside City limits. However, the property owned by the School District, approximately 41 acres, was previously annexed to the City, and is the only property within the Fox Ridge Road area already in City limits.

Comprehensive Plan Map. The properties in the area have a Comprehensive Plan Map designation of Urban Holding (UH), which means the Area Planning/Master Planning process applies prior to annexation, to address the different land uses planned for the area.

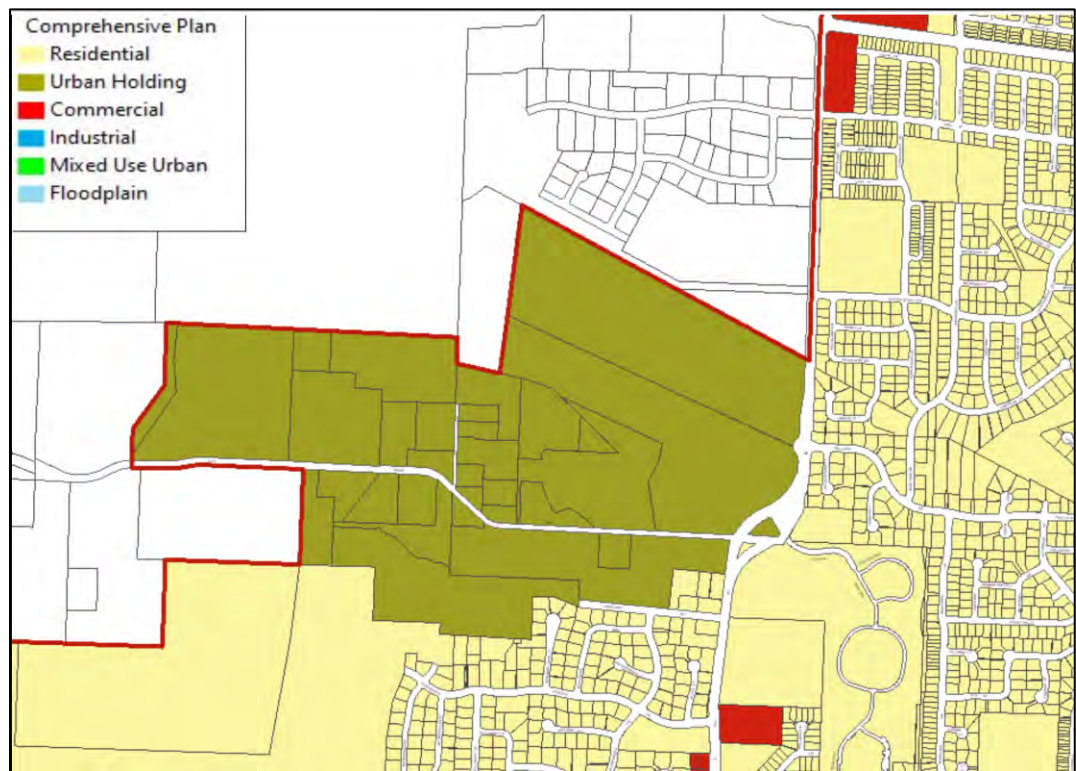

Zoning Map. The School District property was annexed and was rezoned to R-4 PD in 2005, applying a Planned Development Overlay to the property (Ordinance 4829). That ordinance specifies the use of the property is limited to a public high school and ancillary use, subject to an approved conditional use permit.

The other properties in the Fox Ridge Road area are unincorporated. Therefore, they are currently subject to the County zoning and county land use regulations which continue to apply to those properties unless/until they are annexed and rezoned to City zoning. Therefore, any land use and building permit applications for those properties are processed by the County prior to annexation.

The predominant county zoning of the area is rural residential (VLDR-2.5) in the central area, with agricultural zoning (AF-10 and EF-80) of properties near the west end of the Fox Ridge Road area and south of the School District property. Public and institutional use zones apply to the McMinnville Water and Light property and the cemetery.

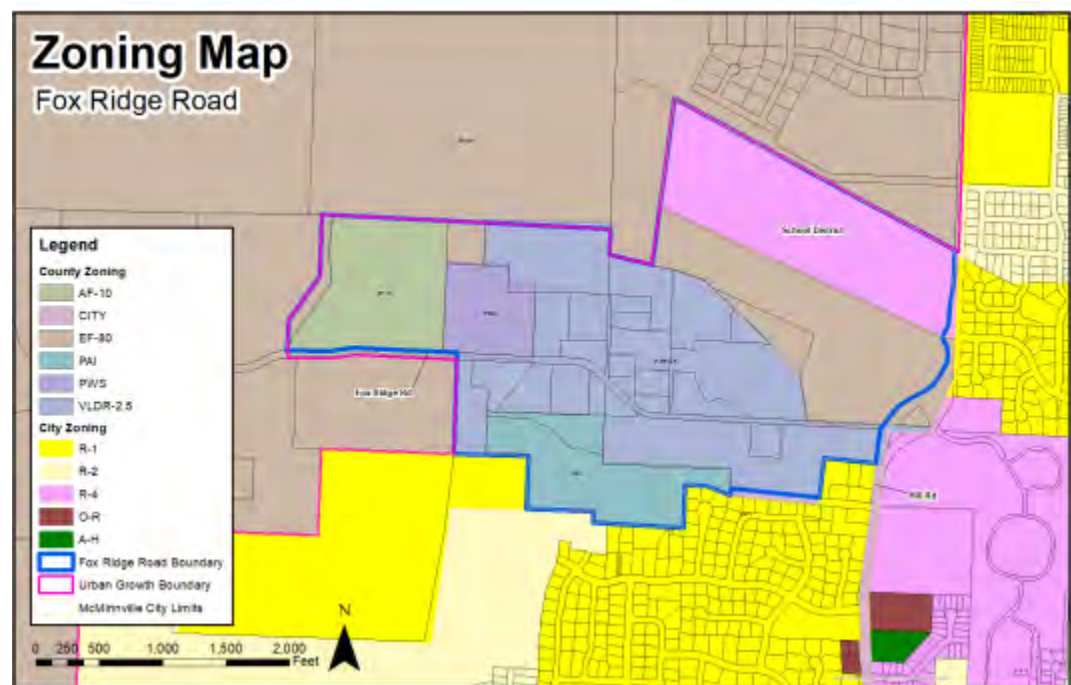

Existing Land Uses. The properties with VLDR-2.5 zoning are predominantly developed with single-detached homes, with approximately 19 developed homesites, with most situated to take advantage of the views of McMinnville, the Willamette Valley, and the surrounding hills and mountains. Most of these residential sites have existing barns, storage buildings, workshops, or other assorted outbuildings.

Other existing uses in the area include the Masonic Cemetery, McMinnville Water and Light facilities, the Christmas tree farm, and the quarry.

The MGMUP and Framework Plan, adopted as part of the Comprehensive Plan in 2020, outline the planned land uses for the Fox Ridge Road area, summarized above in this document.

3.4 NATURAL FEATURES

Data regarding natural features was inventoried as part of the MGMUP planning work. The City has also initiated work on a “Goal 5” (Natural Resources) per state law.

3.4.1 HABITAT AND NATURAL FEATURES

The Fox Ridge Road Area includes several existing natural and geographic features. Existing tree groves are shown on the Opportunities and Constraints Diagram. The area also includes winter, summer, and year-round habitat for three avian species identified by ODFW as Species of Concern: Western Bluebird, White-Breasted Nuthatch (Slender-Billed), and Olive-Sided Flycatcher. The quarry pond is also used by wildlife. There are opportunities to coordinate natural greenspaces or greenways to connect the Fox Ridge Road Area to the West Hills and Redmond Hill Road areas. Greenway/greenspace features could also be located to minimize impacts to the significant tree stands in the Fox Ridge Road and West Hills areas that currently provide habitat.

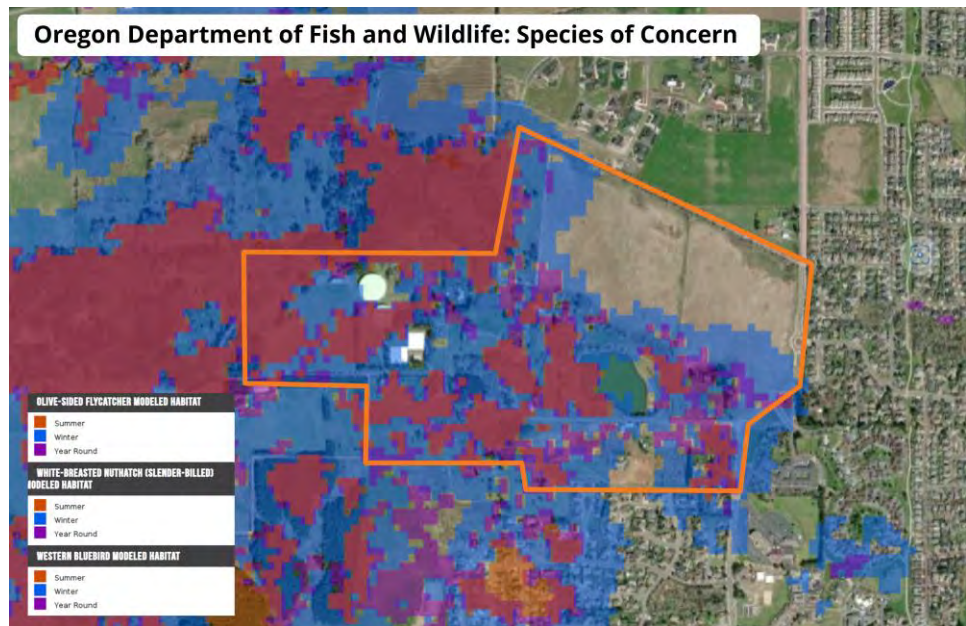

3.4.2 HAZARDS

As part of the analysis of study areas conducted for the UGB study areas, the City inventoried hazards. The predominant hazards in the Fox Ridge Road area are geologic and wildfire hazards. There is no mapped floodplain within the Fox Ridge Road area. Following the 2020 UGB amendment, the City initiated planning for “Goal 5” (Natural Resources) and “Goal 7” (Natural Hazards). The Natural Hazards Planning work is in the public hearing process. The plan includes proposed implementation measures that establish two overlay zones based on a composite hazard rating: a mitigation zone (NH-M) and a protection zone (NH-P). **See map below.** Areas within the NH-P overlay would be subject to limitations on further land division and development. The implementation measures also include a proposal for transfer of density to allow density/development rights to be transferred to portions of the property or to other properties outside of the NH-P overlay area.

The overlays won't apply to properties unless/until they annex into City limits. Properties remain subject to county land use regulations unless/until annexed.

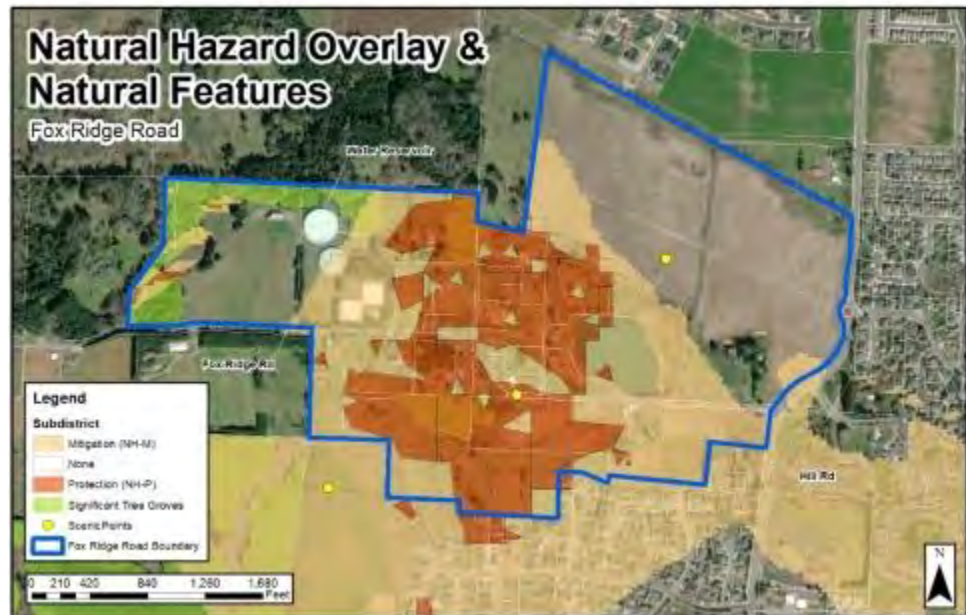

3.4.3 TOPOGRAPHY

The City made findings describing the topography of areas, including, the Fox Ridge Road study area, as part of the MGMUP work, including analysis of slopes. Mapping of moderate (15-25%) and steep (>25%) slopes was conducted. The steep slopes are shown as part of the information on the attached Opportunities and Constraints diagram.

3.4.4 LANDSCAPE AND VIEWS

The Fox Ridge Road area is characterized by its moderate to steeply sloping terrain, dense stands of mature tree groves and the expansive views of the surrounding lands. The north and northeast portions of this study area are larger parcels that have historically been agriculture. The area slopes upwards from NW Hill Road to the west, affording some of the best views of McMinnville within the area. In addition to encouraging the preservation of the existing landscape to the extent possible, the Fox Ridge Road Area Plan intends to incorporate one neighborhood park of approximately 3 – 5 acres in size, as well as greenways or trails throughout the area for both passive and active recreational opportunities within the area.

3.5 INFRASTRUCTURE AND SERVICES

3.5.1 TRANSPORTATION

Fox Ridge Road itself is a paved, County rural road with no sidewalks, curb or gutter. The road extends westward from Hill Road providing the only means of public vehicular access into the study area. Fox Ridge road generally travels along the ridgeline that cuts east-west through the study area's midsection. Additional access to individual parcels within the study area is provided by long and narrow private driveways and Dawson Lane. The right-of-way dimension for Fox Ridge Road measures 40-feet in width, and includes a constructed paved surface that

averages 25-feet in width with narrow gravel shoulders on either side. The road will require improvements as the area urbanizes to meet City design standards. The City’s complete street standards provide for curb, gutter sidewalk, and planter strips on both sides of the street. The standard for a local street specifies 28 feet paved width within a 50-foot right-of-way. The plan may consider an alternative section that provides for a separated multi-use path.

Hill Road was recently constructed with curb, gutter, sidewalk, bike lanes and landscaping. The intersection with Wallace Road was constructed with a roundabout, designed to accommodate a fourth leg to the west. The intersection at Hill Road and Fox Ridge Road is currently a through movement on Hill Road with stop-sign control on Fox Ridge Road. Information regarding the Transportation System Plan is provided below in the “Planning and Regulatory Framework” section. Please see information in that section below.

The County adopted an updated transit plan in 2018, and the City subsequently adopted this as part of the transportation plan. Transit service is not currently present along Hill Road, but the transit plan identifies future transit service areas. The City should continue to coordinate with Yamhill County regarding coordination of transit to serve Hill Road. The plan identifies potential future service along Hill Road which could ultimately benefit the Fox Ridge Road study area. See the figure below (*Figure 2-11 from the YCTA plan identifying areas that would potentially benefit from future transit service*). The Fox Ridge Road study area is located between areas 1b and 1c. Higher densities and other plan elements within the area would potentially increase the demand for these services sooner than later.



The City will also be coordinating with Yamhill County Transit as part of the Fox Ridge Road Area Plan in order to better understand the potential for future public transit services to connect Baker Creek Road, Hill Road, and 2nd Street. Yamhill County Transit updated their transit plan in 2018, with future short- to long-term service expansions discussed within the region. The transit plan indicates that,

“McMinnville’s R-3 residential zoning district allows nearly 12 units per acre and the R-4 residential district allows for higher-density developments (over 20 units per acre), which could support transit service that is more frequent than today; however, current residential density in the city is relatively low, even in areas currently zoned for medium- or higher-density housing.”

Connectivity and coordination with the development of the high school site will be important in the Fox Ridge Road Area Plan. Any trail networks considered will incorporate connectivity to the future school site. Bike and pedestrian connectivity will be considered in the Area Plan, with consideration of connecting to the existing trails and linear parks (BPA and Westside trail systems) that are located just east within the existing Urban Growth Boundary (UGB). The trail system may potentially be linked via Wallace Road.

3.5.2 UTILITIES (WATER, SEWER, STORMWATER, AND OTHER)

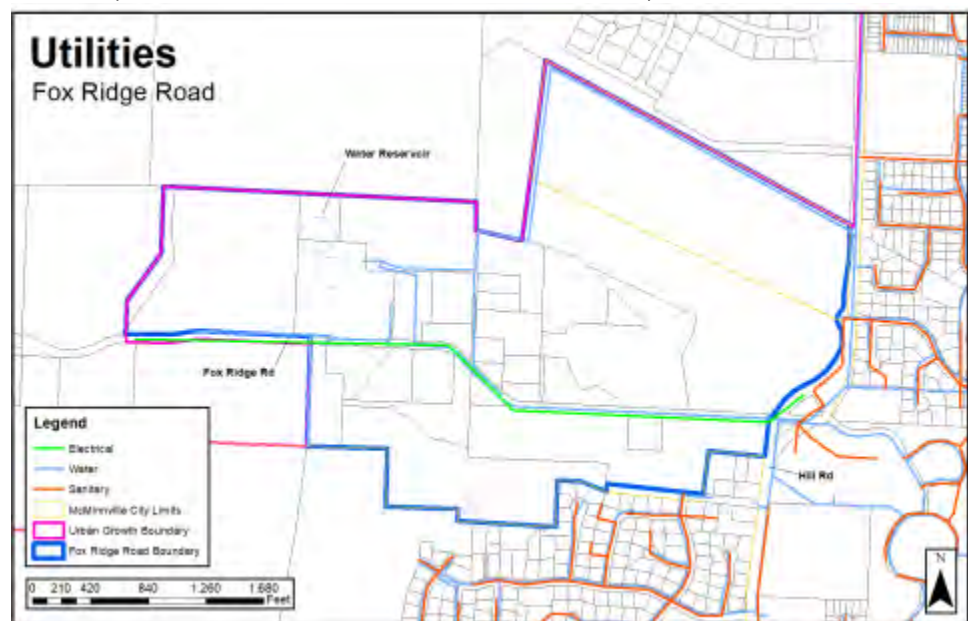

Because the property is still unincorporated and developed under county land use regulations, urban services haven’t generally been extended outside of City limits. Properties within the area are generally served by wells and private on-site septic systems, and Fox Ridge Road is constructed as a rural road. Because of the MWL facilities located in this area, there is municipal water infrastructure within this area which is extended to serve McMinnville with legacy connections to some nearby properties. Where the Fox Ridge Road area is adjacent to city limits, there are locations where urban services are present along the street frontage of the area and/or are already stubbed or planned to be stubbed to the area in public right-of-way from adjacent developments.

When properties annex to the City, they are rezoned to city zoning and develop to city standards with developer-installed provision of urban services including municipal sewer and water, and streets improved to city standards for new development. The key public facility plans are currently in the process of being

updated, including water; wastewater; stormwater; transportation; and parks, recreation, and open space.

Water

McMinnville Water and Light (MWL) is in the process of updating the Water Distribution Plan. Provision of municipal water service requires a system that meets domestic needs, provision of water for fire-fighting, and adequate flows and minimum and maximum water pressures. This requires a system designed with different water pressure zones based on the elevation range of the area being served. Nearly all of McMinnville is in Water Pressure Zone 1, and the system is designed to serve this zone. Serving higher elevation zones requires separate storage, gravity, and/or pumping facilities for the higher elevation zones. Properties in the Fox Ridge Road Area include elevations corresponding to pressures Zones 1, 2, and 3. The corresponding elevations are:

- Zone 1: 0'-250'
- Zone 2: 250'-400'
- Zone 3: 400'-538'

These are shown on the map below.

Approximate Water Pressure Zone Boundaries

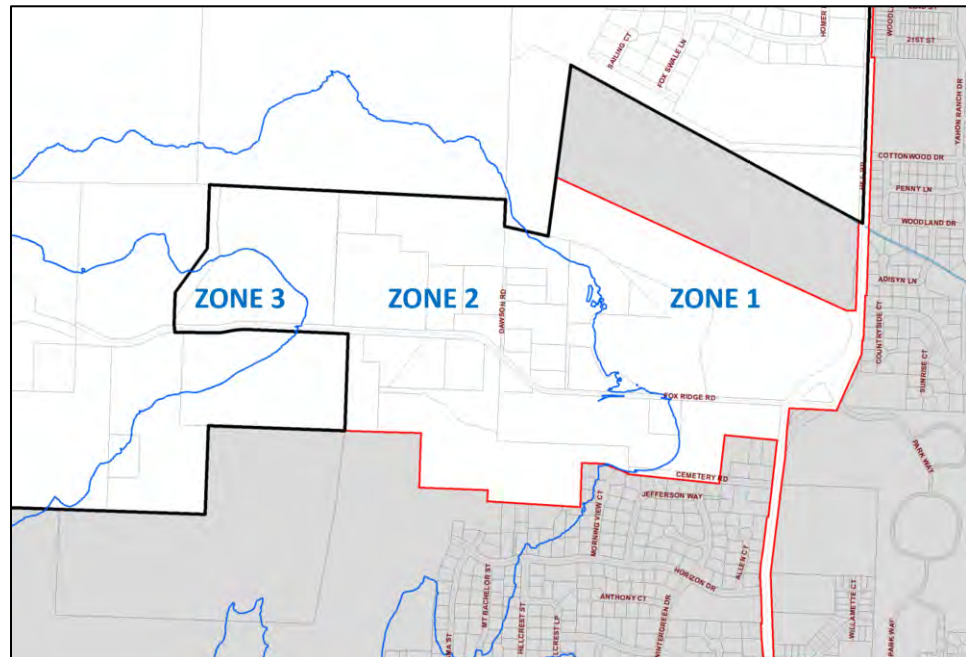

The Zone 1 properties can be served without the need for a higher level reservoir or a pump station which will be needed to serve Zones 2 and 3. To date, properties in Zone 2 and 3 have generally not yet been served with water, with limited exceptions. (A few homes at the threshold between Zones 1 and 2 were previously developed using private booster pumps, but that is not an option for serving an entire service area within a pressure zone). MWL owns a site intended for a future reservoir to serve Zone 2 west of this area. In the interim, there can be consideration of how to best phase service to serve smaller/phased developments

and address the funding of the necessary pump station or reservoir improvements if there isn't initially a critical mass or economy of scale sufficient to distribute fixed costs among new homes to be served in the early development phases or when properties aren't contiguous.

Sanitary Sewer

The Sanitary Sewer Conveyance System Mater Plan was adopted in 2008. The City of McMinnville is currently in the process of updating the plan. The 2008 master plan addressed future growth within the UGB including the Fox Ridge Road area.

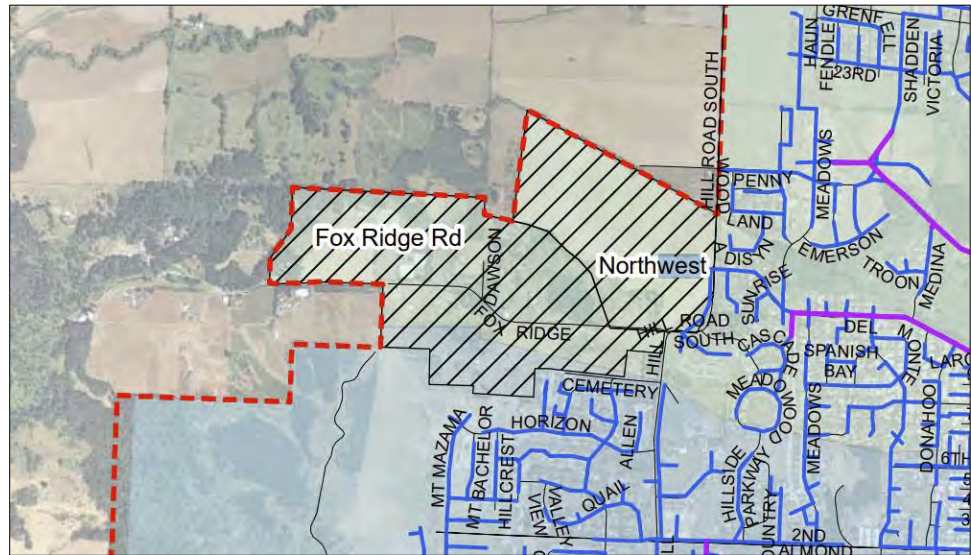

Table 3-5. Developed Land Within Proposed UGB – Future Additional

Basin	Residential		Commercial/Industrial		Total EDUs
	Acres	EDUs	Acres	EDUs	
Airport	261	831	231	2,772	3,603
Cozine	500	2,209	16	192	2,401
Downtown	11	48	28	336	384
Fairgrounds	361	1,307	192	2,304	3,611
High School	5	25	8	96	121
Michelbook	400	1,590	14	168	1,758
Yamhill	1	3	0	0	3
Total	1,539⁽¹⁾	6,013	489	5,868	11,881

(1) Includes approximately 531 acres containing residential land designation that has been identified for use other than for housing—schools, parks, religious, government, semi-public services, and infrastructure.

Table 3-6 summarizes the total area distribution of developed land within the planning area at buildout.

Table 3-6. Developed Land Within Proposed UGB – Buildout Total Net Area

Basin	Residential (Acres)	Commercial/Industrial (Acres)	Total Acres
Airport	373	396	769
Cozine	1,097	64	1,161
Downtown	208	169	377
Fairgrounds	655	661	1,316
High School	332	126	458
Michelbook	640	19	659
Yamhill	53	19	72
Total	3,358	1,454	4,812

Gravity flow is more cost-effective than pumping. Due to the site's topography, sanitary sewer effluent would gravity flow in two general directions: to the east into the Michelbook basin; and, to the south into the Cozine basin. There are opportunities to connect to the existing system where conveyance pipes are present to the east at Hill Road and to the south at the northerly terminus of the sewer main in Wintergreen Drive at Cemetery Road. Public sewer mains are typically installed in public right-of-way, and some of the upper elevation areas generally slope to the northeast and could gravity flow in that direction if there are adequate opportunities for public right-of-way connections or possible use of easements over public lands. Provision of a sewer line in the future street extension which is part of the Hillcrest Planned Development master plan will also provide an additional opportunity for connection to the sewer system to the south near the southwest corner of the Fox Ridge Road area.

The City conducted additional flow monitoring in 2019 and identified potential downstream capacity limitations that will be addressed in the stormwater master plan update and could require upsizing of some sections downstream pipe prior to or concurrent with development in the Fox Ridge Road area above a certain threshold.

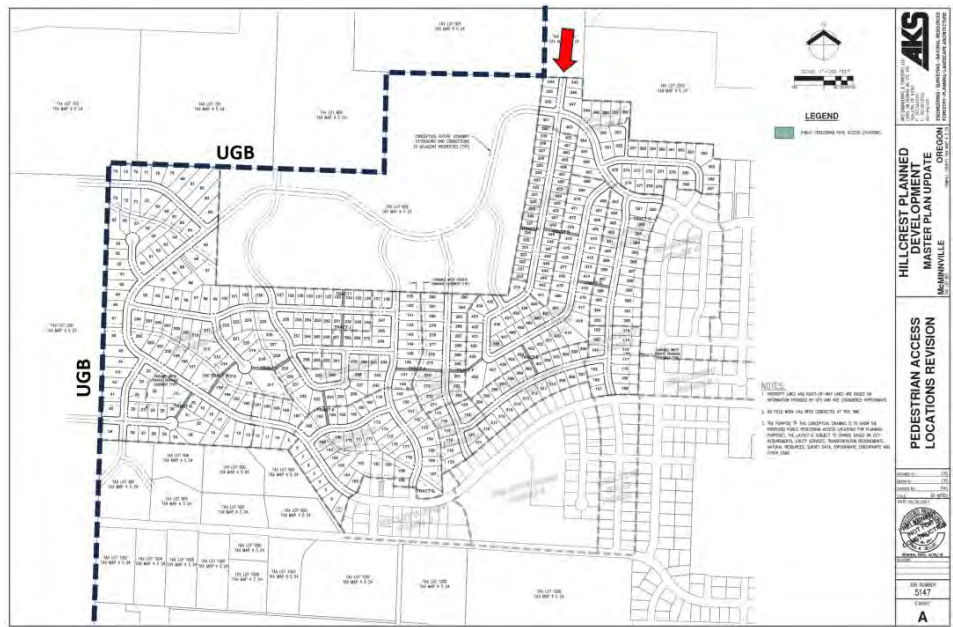

Stormwater

The City is in the process of updating the 2009 stormwater master plan. Stormwater runoff in the study area is predominantly to natural drainageways and in part to the quarry pond. Stormwater treatment facilities are present along Hill Road and stormwater conveyance pipe is present in the adjacent neighborhoods within city limits abutting the Fox Ridge Road area to the south and east of the Fox Ridge Road area that may be connected to any new storm pipes extended as part of the area plan. There is some surface water runoff to the existing quarry pond. The water rights for the quarry are separately owned from the land. The water collected in the quarry pond currently provides irrigation water to the golf

course property and the West Wind development to the north. As part of new development, stormwater management plans are required.

Electric

There are existing feeders on North Hill Road that would have to be upgraded to accommodate the additional projected load.

3.5.3 COMMUNITY FACILITIES AND PROXIMITY

Resource	Facility	Address	Location
Schools	Newby Elementary School	1125 NW 2 nd St	1 mile – East
	Duniway Middle School	575 NW Michelbook Ln	1 mile – East
	Memorial Elementary School	501 NW 14 th St	1.5 miles – East
	McMinnville High School	615 NE 15 th St	2 miles – East
Higher Education	Linfield University	900 SE Baker St	2 miles – SE
	Chemeketa Community College	288 NE Norton Ln	3.5 miles – SE
Parks	Jay Pearson Neighborhood Park	2120 NW Yohn Ranch Dr	0.6 miles – NE
	Westside Bicycle and Pedestrian Greenway	Runs north/south NW Baker Creek Rd to SW 2 nd St	0.5 miles – East
	McMinnville Linear Park	Runs east/west S. Agee St to SW Westvale St	0.6 miles – SE
Hospitals	Oregon Whole Health	349 SE Baker St	1.6 miles – SE
	Physicians Medical Center	2435 NE Cumulus Ave	3.3 miles – SE
	Willamette Valley Medical Center	2700 SE Stratus Ave	3.3 miles – SE
Police Stations	McMinnville Police Department	121 SE Adams St	1.6 miles – SE
	Yamhill County Sheriff's Office	535 NE 5 th St #143	1.8 miles – SE
Fire Station	McMinnville Fire Department	175 E 1 st St	1.6 miles – SE
Playground	Scotty's Playhouse Indoor Playground	700 NW Hill Rd	0.1 mile – East
Senior Care	The Manor at Hillside Retirement Community	900 NW Hill Rd	0.1 mile – East
	The Village at Hillside Assisted Living Facility	440 Hillside Pkwy	0.3 mile – SE
	Traditions at Hillside Retirement Community	300 Hillside Pkwy	0.3 mile – SE
	Vineyard Heights Assisted Living Facility	345 SW Hill Rd	0.5 mile – South
	McMinnville Memory Care	320 SW Hill Rd S	0.5 mile – South
Cemetery	Masonic Cemetery	NW Cemetery Rd	0 miles

4.0 REGULATORY CONTEXT AND PLANNING FRAMEWORK

The Fox Ridge Road Area Plan will be adopted as a supplement to the McMinnville Comprehensive Plan and adopted by the City Council as a guiding land use document. The Area plan must embody the development principles of the McMinnville Comprehensive Plan, including the MGMUP, the Framework Plan, and other applicable City land use policies. The MGMUP provides guidance for the planning and development of fully integrated, mixed-use, pedestrian-oriented neighborhoods. The Area Plans are expected to be developed consistent with:

- 1) The guidelines of the Traditional Neighborhood model, as described in the McMinnville Growth Management and Urbanization Plan.
- 2) Neighborhood Activity Centers (NACs) to meet neighborhood commercial land needs as identified in the MGMUP Framework Plan, and support surrounding residential development.
- 3) The City's adopted Great Neighborhood Principles, as described in Comprehensive Plan Policies 187.10 through 187.50.

4.1 MCMINNVILLE GROWTH MANAGEMENT AND URBANIZATION PLAN

Traditional Neighborhood Model Guidelines

As highlighted in the MGMUP, McMinnville's plan for urbanization is modeled around the planning and development of a "traditional neighborhood," designed to be fully integrated, mixed-use, and pedestrian oriented. This type of development includes narrower streets that emphasize pedestrian orientation and scale, highly connected street patterns with small blocks or grids, streets lined with trees and sidewalks on both sides, and diverse housing types and lot sizes that are intermixed throughout the neighborhood. Uses and housing types are mixed and in close proximity to one another, with public spaces such as neighborhood parks or plazas serving as focal points for community interaction. As an essential feature, the McMinnville model for a traditional neighborhood calls for a neighborhood activity center at the heart of the neighborhood to provide opportunities for social interactions, structure to surrounding land uses, and neighborhood identity. The concept of a traditional neighborhood aims to minimize traffic congestion, suburban sprawl, infrastructure costs, and environmental degradation.

To be consistent with the MGMUP, the Fox Ridge Road Area Plan will follow the guidelines set forth for the development of a traditional neighborhood model. As the Area Plan is conceptually planned and refined, key considerations for the subarea include mixed-use planning that integrates diverse commercial and residential developments, pedestrian oriented and connected streets, and public green spaces as social gathering opportunities. A partial neighborhood activity center is expected to be a focal point of the subarea.

4.2 MCMINNVILLE FRAMEWORK PLAN

The Framework Plan is Appendix G of the MGMUP, adopted in 2020 as part of the Comprehensive Plan.

Neighborhood Activity Centers (NACs)

The MGMUP emphasizes Neighborhood Activity Centers as the most critical element of the City's growth management and land use plan. Accordingly, the Framework Plan identifies general locations for NACs. Surrounding the neighborhood activity center are residential uses with the highest-density housing developments that progressively decrease in density outward from the activity center.

According to the MGMUP:

- The location of a neighborhood activity centers should be selected based on their proximity to vacant buildable land.
- Have the ability to accommodate higher intensity development.
- Provide local context with the ability to foster the development of a traditional neighborhood.
- Located at major street intersections with their service areas extending to a group of neighborhoods ranging from a one (1) to three (3) mile radius.
- The focus area of a neighborhood activity center should contain facilities necessary for day-to-day activity (such as personal services, grocery and convenience shopping, schools, places of worship, limited office space, public plazas or parks) and ideally located within close proximity to one another in the focus area so that all essential services for the subarea are easily accessible in a single stop.
- The support areas that surround the activity center's focus area should contain the neighborhood's high- to medium-density housing options and enables the highest concentration of population to easily access the focus area within walking distance (reducing the number of automotive trips for daily needs or services and allows for a single transit stop to serve the shops, services, and adjacent higher-density housing in the subarea).

Shown in the MGMUP Framework Plan, the Fox Ridge Road Area Plan is planned to provide an opportunity for a partial Neighborhood Activity Center. The development of the neighborhood activity center allows for a traditional neighborhood that will be livable, healthy, social, inclusive, safe and vibrant, meeting all the Great Neighborhood Principles within the Comprehensive Plan.

Fox Ridge Road Area as shown in MGMUP Framework Plan:



As described in the Framework Plan, the partial Neighborhood Activity Center will be approximately 5 – 10 acres, with approximately 1 – 2 acres of commercial and office development to serve the neighborhood, approximately 2 acres of high-density residential development (R-5), and approximately 2 – 5 acres of medium density residential housing. This mixed-use center is proposed to be located along the area's Hill Road frontage

between the Wallace Road roundabout and the intersection of Fox Ridge Road. The remainder of residential land within the Fox Ridge Road study area is most suitable for lower density residential housing due to the presence of steep slopes and natural hazards (i.e., areas subject to landslides). The location, uses, and accessibility of the Neighborhood Activity Center ensure the study area's consistency with the City's adopted Great Neighborhood Principles described in the MGMUP.

4.3 COMPREHENSIVE PLAN – VOLUME II: GOALS AND POLICIES

Volume II of the Comprehensive Plan provides goals and policies in nine chapters by topic. Among the most critical provisions for area planning are the Great Neighborhood Principles.

Great Neighborhood Principles

Adopted in 2019, the Great Neighborhood Principles are incorporated as policies in the Urbanization Goal of Volume II of the Comprehensive Plan as Policy 187.10, described as a means to guide the land use patterns, design, and development of the places that McMinnville citizens live, work, and play. These principles ensure the livability, accessibility, safety and beauty of all new development or redevelopment. The following are the 13 principles described in the policy:

1. Natural Feature Preservation
2. Scenic Views
3. Parks and Open Spaces
4. Pedestrian Friendly
5. Bike Friendly
6. Connected Streets
7. Accessibility
8. Human Scale Design
9. Mix of Activities
10. Urban-Rural Interface
11. Housing for Diverse Incomes and Generations
12. Housing Variety
13. Unique and Integrated Design Elements

In order for the Fox Ridge Road Area Plan to be consistent with these principles, Comprehensive Plan Policy 187.50 provides policies on how to achieve each of the listed principles as it refers to design, location and orientation of these necessary neighborhood resources. By following the model of a traditional neighborhood and planning around the centralization of a partial neighborhood activity center, the overall development of the area plan is intended to achieve each individual principle.

4.4 TRANSPORTATION SYSTEM PLAN AND TRANSPORTATION ISSUES

The City's Transportation System Plan (TSP) was adopted in 2010. The plan was adopted prior to the 2013 UGB remand, and therefore the TSP was based on the same boundary for Fox Ridge Road that exists following the 2020 UGB amendment, and the MGMUP in place at that time also planned for a Neighborhood Activity Center in this area. See Exhibit 3-1 from the TSP below. At that time, the Comprehensive Plan designation was Residential (R). It is now Urban Holding (UH).

The Comprehensive Plan and the Transportation System Plan are plans for the UGB overall, not just the portion within City limits, so the 2010 TSP included planning for the Fox Ridge Road Area.

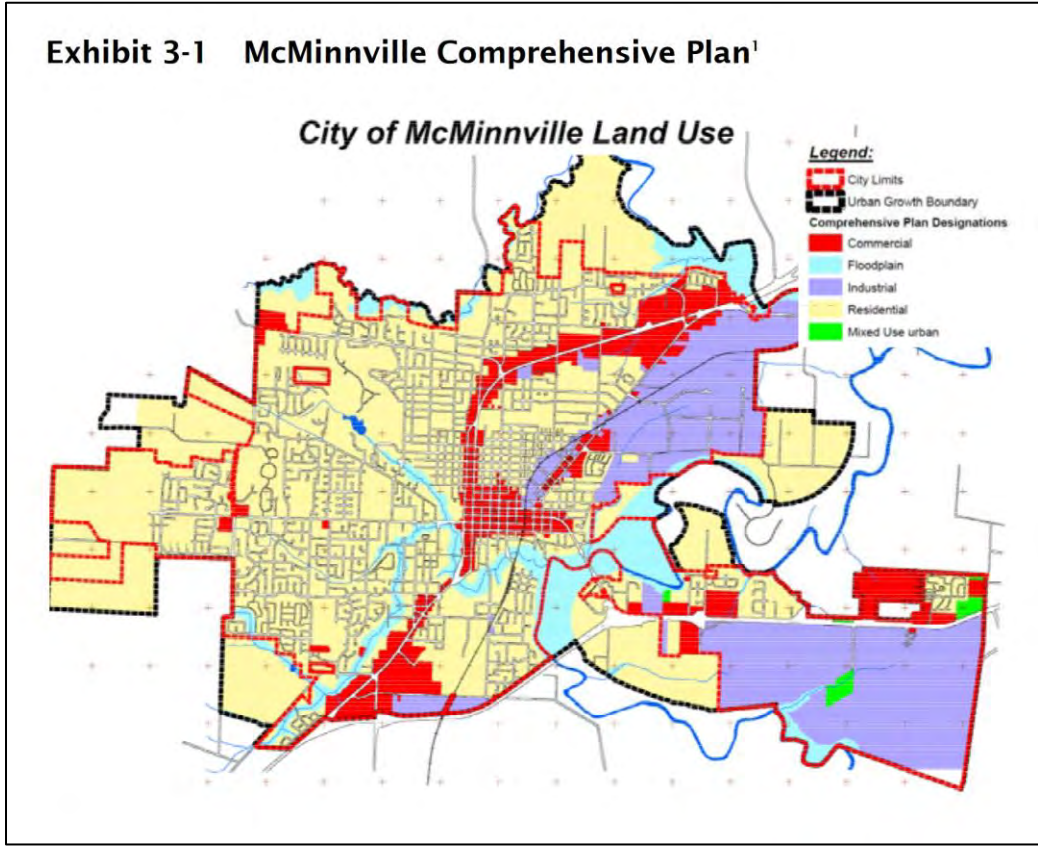

Exhibit 2-3 of the TSP, below, shows existing and planned functional classification of streets. Hill Road is classified as a Minor Arterial. The other streets in the study area are classified as local streets. These classifications are used to determine issues such as complete street design standards, access management, etc.

Complete Streets

Development per city standards includes street designs for complete streets for all modes.

Access Management

Because Hill Road is classified as a Minor Arterial, access management policies will likely limit direct access to Hill Road to the existing public streets at the west leg of the Wallace Street roundabout and the Fox Ridge Road intersection.

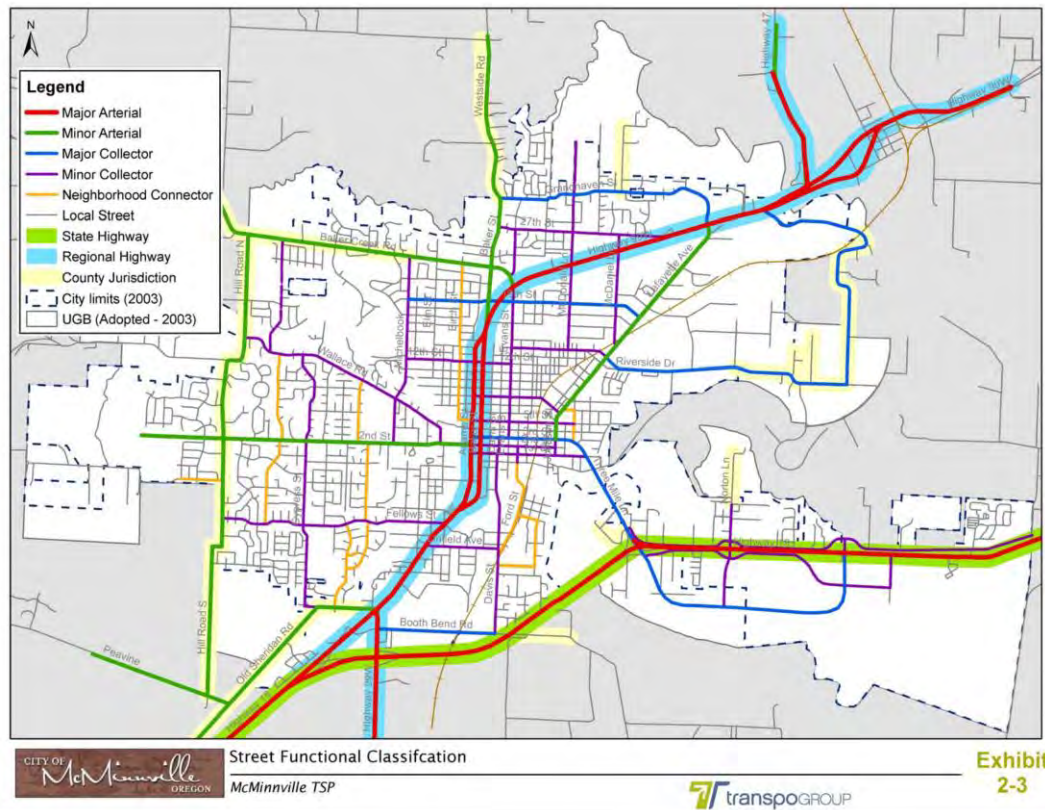

Connectivity

Transportation policies outline the need for a well-connected street network to serve all modes of transportation and to provide multiple routes for public safety ingress and egress. In part, this is achieved by street connectivity standards for land divisions that specify maximum block length and perimeter standards, limitations on the use of cul-de-sac and permanent dead-end streets, etc. In addition, the TSP includes a map which identifies where certain local street connections are critical. See Exhibit 2-1 below. This shows the approximate location of connection that are needed for local streets, without showing specific local street alignments. Connectivity for existing and future streets of higher classifications are shown on Exhibit 2-3, which also indicates general alignments needed.

Due to topography, existing parcelization, and location of existing land uses such as the cemetery and McMinnville Water and Light property, there may be some limitations to achieving street connectivity in some locations. Exhibit 2-1 identifies needs for at least local street connections from the westerly extension of Wallace Road to the south and allowing for an extension of Wintergreen Drive from Cemetery Drive north to Fox Ridge Road. Additional street connectivity to the south is limited by the location of the cemetery and the westerly extent of the UGB. There may also be limitations for street connectivity due to topography between the lower elevation northerly properties and the higher elevation southerly properties further to the west. If topography limits the extent of street connectivity in that vicinity, there is also the potential to instead provide non-vehicular connectivity for pedestrian and/or bicycle connections in those locations, as addressed in Chapter 17.53 of the Zoning Ordinance.

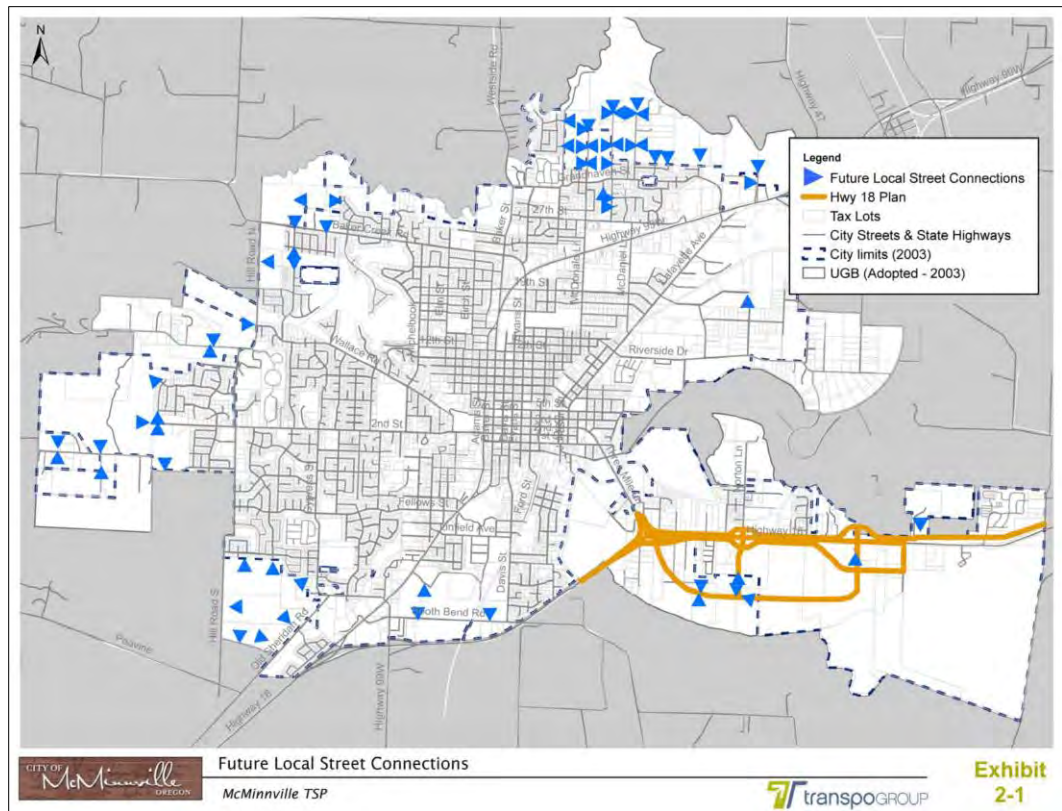

It is also noted that the Hillcrest Planned Development is located in City limits to the southwest of the Fox Ridge Road Area. The Planned Development has an approved master plan which includes a street connection to the Fox Ridge Road area west of the cemetery, just inside the UGB. See below.

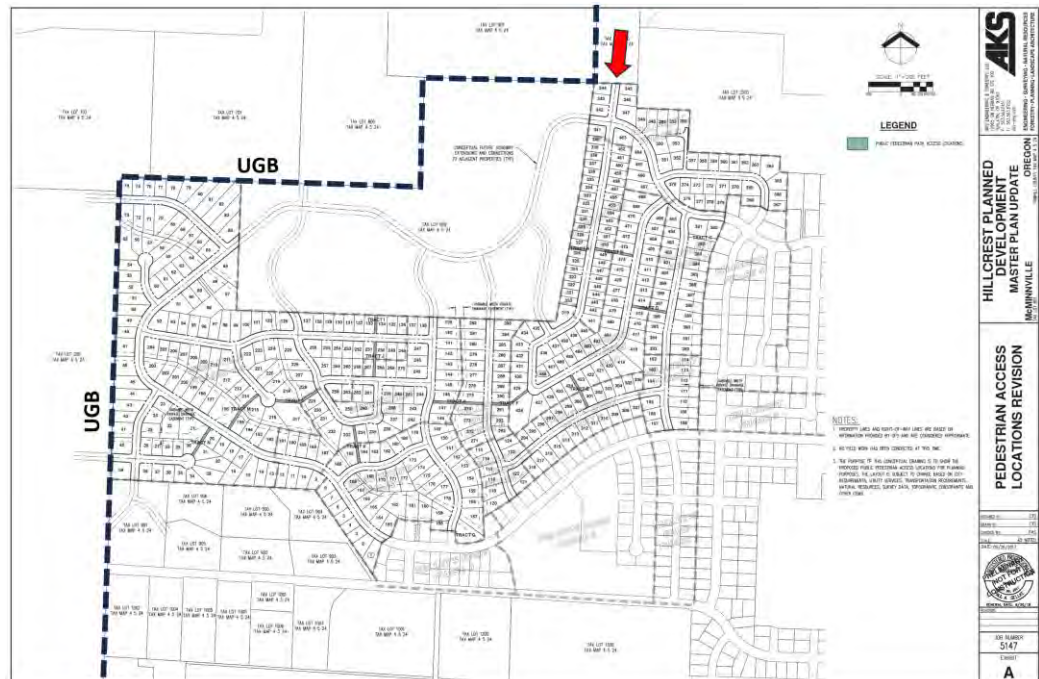

Traffic

In the TSP, the City has established performance standards for transportation facilities. In advance of construction of the Hill Road improvements, traffic analysis was conducted in 2016, including evaluation of different intersection designs and traffic control options. The analysis evaluated the capacity of the roundabouts at Wallace Road and Baker Creek Road including traffic from projected growth. Table 6, excerpted below, summarizes the results. With existing traffic and projected growth, the roundabouts were projected to operate at Level of Service(LOS) A during both the am and pm peak hours.

Table 6. Peak-Hour Intersection Analysis (2035 Alternative Roadway/Intersection Configuration)

Intersection Name	2035 (Existing Channelization)			2035 (With Improvements)			
	Average Vehicle Delay (sec)	Level of Service	V/C Ratio	Improvement Type	Average Vehicle Delay (sec)	Level of Service ¹	V/C Ratio
AM Peak-Hour							
1 NW Hill Road/ NW 2nd Street	32.9	D	0.86 (EBL/T/R)	Complete Streets, Stop-control	24.0	C	0.80 (EBL/T/R)
				Complete Streets, Signalization	12.5	B	0.62 (Int)
				Roundabout	9.7	A	0.63 (Int)
2 NW Hill Road/ Wallace Road	59.7	F	0.77 (EBL/R)	Complete Streets, Stop-control	55.3	F	0.75 (EBL/R)
				Complete Streets, Signalization	9.5	A	0.42 (Int)
				Roundabout	7.6	A	0.51 (Int)
3 NW Hill Road/ NW Cottonwood Drive	17.4	C	0.40 (WBL/R)	Complete Streets, Stop-control	17.3	C	0.40 (WBL/R)
				Complete Streets, Signalization	8.1	A	0.48 (Int)
				Roundabout	5.0	A	0.38 (Int)
4 NW Hill Road/ NW Baker Creek Road	29.0	D	0.80 (NBL/R)	Complete Streets, Stop-control	16.6	C	0.61 (NBL)
				Complete Streets, Signalization	12.9	B	0.43 (Int)
				Roundabout	6.6	A	0.62 (Int)
PM Peak-Hour							
1 NW Hill Road/ NW 2nd Street	49.8	E	0.93 (SBL/T/R)	Complete Streets, Stop-control	30.0	D	0.92 (WBL/T/R)
				Complete Streets, Signalization	8.4	A	0.53 (Int)
				Roundabout	9.2	A	0.63 (Int)
2 NW Hill Road/ Wallace Road	24.4	C	0.39 (WBL/R)	Complete Streets, Stop-control	23.9	C	0.38 (WBL/R)
				Complete Streets, Signalization	10.2	B	0.46 (Int)
				Roundabout	5.5	A	0.47 (Int)
3 NW Hill Road/ NW Cottonwood Drive	18.6	C	0.31 (WBL/R)	Complete Streets, Stop-control	18.3	C	0.30 (WBL/R)
				Complete Streets, Signalization	5.2	A	0.36 (Int)
				Roundabout	4.9	A	0.40 (Int)
4 NW Hill Road/ NW Baker Creek Road	52.2	F	0.92 (NBL/R)	Complete Streets, Stop-control	44.6	E	0.48 (NBL)
				Complete Streets, Signalization	10.2	B	0.43 (Int)
				Roundabout	6.5	A	0.51 (Int)

¹ Level of service is based on vehicle delay, and not on volume-to-capacity ratio.

Average vehicle delay reported in seconds.

Int. = intersection (result is reported for overall intersection operations).

Two-way stop-controlled analysis results are reported for the worst operating movement and based on HCM 2010 methodology.

All-way stop-controlled analysis results are based on HCM 2010 methodology.

Roundabout analysis results are based on HCM 2010 methodology.

Additional traffic analysis is also being conducted as part of the scope of work for the Fox Ridge Road Area Plan.

Public Safety

The City has adopted street standards designed to ensure adequate access for public safety vehicles including fire trucks. Street standards specify maximum grades. In addition, fire sprinklers are required for residential and commercial structures accessed from roads with grade exceeding 12 percent slope.

4.5 TRANSIT PLAN

Yamhill County adopted a new transit plan in 2018: the Yamhill County Transit Area Transit Development Plan. In 2021, the City of McMinnville adopted this plan as a supplemental document to the McMinnville Transportation System Plan (TSP) and amended Chapter 7 of the TSP accordingly.

Figure 6-19 McMinnville Map with Near-Term, Short-Term, and Mid-Term Changes

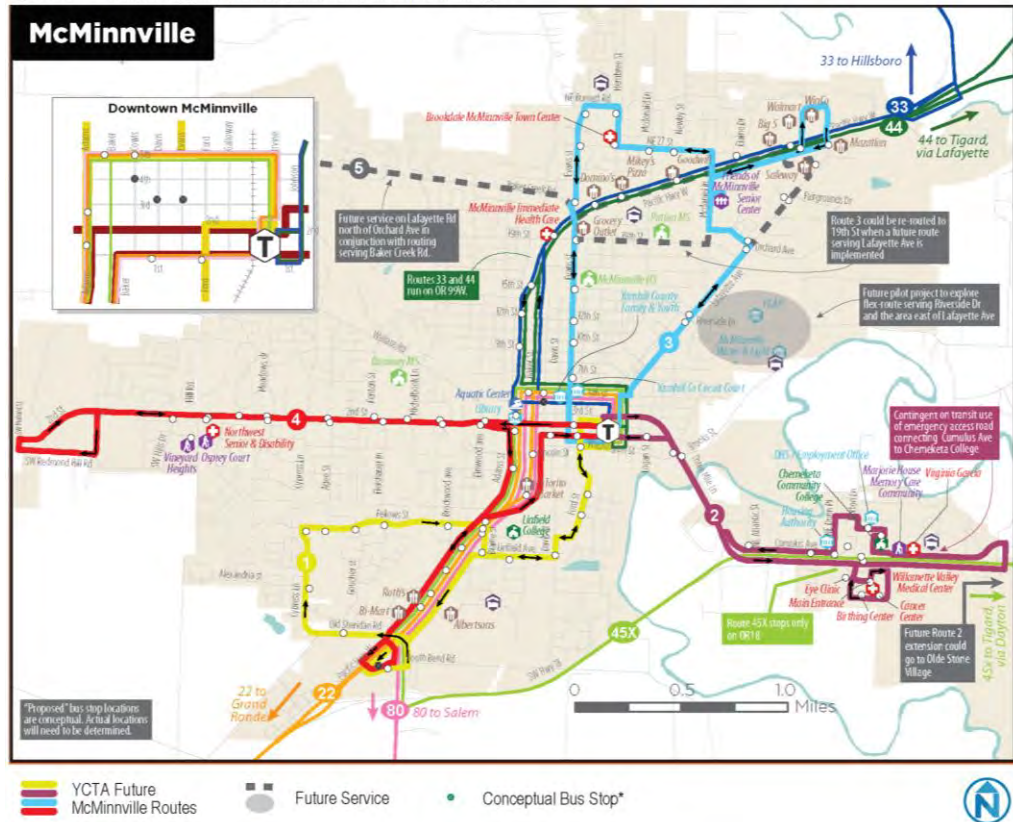
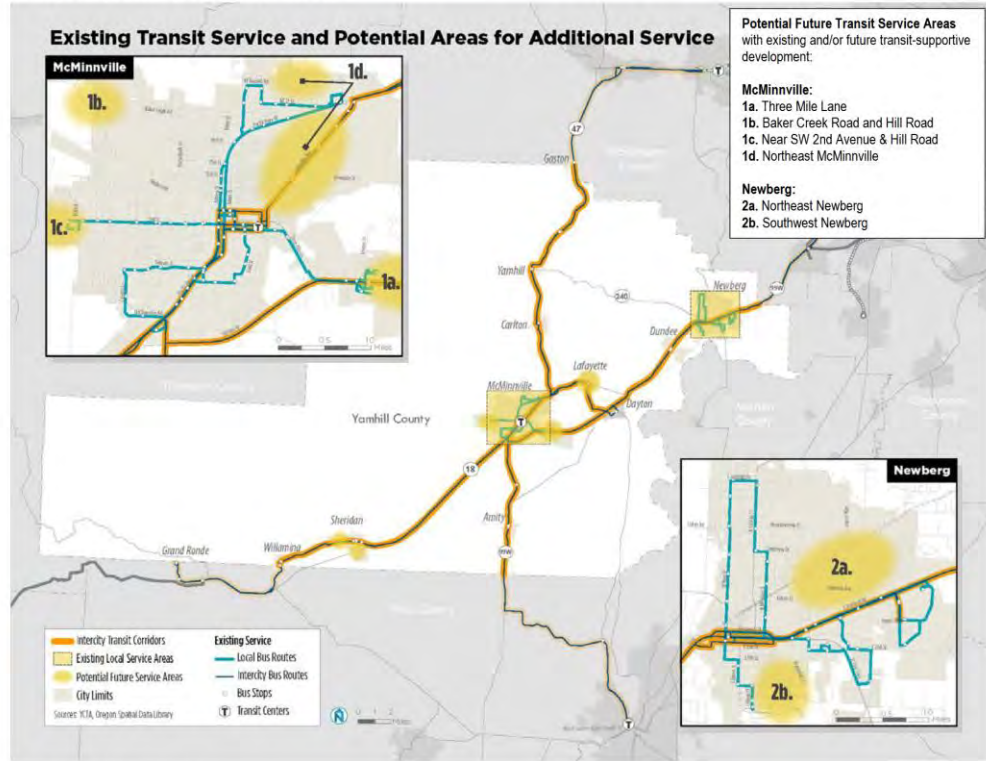

Figure 2-11 Potential Future Transit Service Areas



Source: TM #3, Fig 3-12 (Minor Updates)

Yamhill County Transit Area | 2-18



4.6 MCMINNVILLE MUNICIPAL CODE

Key provisions of the McMinnville Municipal Code include Title 16 which outlines the process for annexation, and Title 17, which is the Zoning Ordinance. Chapter 17.10 outlines the master planning process that applies as specified in Title 16. The Zoning Ordinance also provides the procedures, land use regulations, and standards that apply to rezoning property from rural zoning to urban zoning and development of property that apply when property is within City limits.

Title 16: Annexations

The purpose of the annexation of land is to bring a property into city limits where the city is able to ensure consistency with the McMinnville comprehensive plan while providing a complete range of public services and public facilities to the annexed territory. Currently, the Fox Ridge Road area is undergoing the area planning process required by MMC Chapter 17.10 in order to identify new comprehensive plan designations that will ultimately be applied to subject properties at the time of annexation. These new comprehensive plan designations will identify the future city zoning classifications of properties that will apply in conjunction with annexation to the city. Prior to development of properties within the Fox Ridge Road area, annexation must be completed.

Chapter 17.10: Area and Master Planning Process

Urban Holding Overlay District

As part of the City's UGB expansion areas, the Fox Ridge Road subarea has been assigned the urban holding (UH) comprehensive plan map designation. The Fox Ridge Road subarea must undergo area planning to identify appropriate land uses, their locations, and their relationship to public facilities, natural resources, and other existing urban uses nearby to remove the urban holding designation. Land uses should be consistent with the framework plan. The final Fox Ridge Road Area Plan will be consistent with the Traditional Neighborhood Model, include a Neighborhood Activity Center, and comply with the Great Neighborhood Principles to ensure equitable access to a livable, egalitarian, healthy, social, inclusive, safe and vibrant neighborhood for all of McMinnville's current and future citizens. The final area plan will be adopted by the city council and utilized as a guiding land use document for development within the area. Once adopted, properties within the urban holding zone may annex and assume developable city zones as specified in Title 16 and Chapter 17.10. This initial area planning process has been initiated by the City with the guidance of the Project Advisory Committee appointed by City Council.

Master Planning Process

Within the Fox Ridge Road area, properties with 10 acres or more are required to undergo a master planning process prior to or concurrent with annexation. Several of the properties within the subject area would be subject to the master planning process due to this requirement. Properties over 10 acres looking to develop must demonstrate that they are able to extend services to make urbanization of the area orderly and efficient.

Chapter 17.11: Residential Design Standards

The City of McMinnville has recently amended Title 17 of the McMinnville City Code, adopting a new Chapter (17.11) that includes residential design and development standards. This chapter provides new residential development and design standards for all housing types in McMinnville's residential and commercial zones and reflects the City's vision for housing and development, including the Great Neighborhood Principles. All new development in the Fox Ridge Road study area would be expected to comply with the provisions of Chapter 17.11.

Chapter 17.53: Land Division Standards

In order for annexing properties to urbanize effectively and contiguously with city standards, developable lots planning to subdivide, partition land, or adjust property lines must comply with the regulations of Chapter 17.53 which provides procedures and standards for all land divisions within the city. Partitioning and subdividing of land, and adjustment of property lines within the Fox Ridge Road study area must be able to ensure adequate width and arrangement of streets, coordinate proposed development with plans for utilities and other public facilities, and provide adequate health, sanitation, safety, services, and recreation outlined in the goals and policies of the McMinnville comprehensive plan. These regulations include the following standards for:

- Lot Layout
- Block Length and Perimeter
- Street Connectivity Standards
- Maximum Street Grades
- Utility provision
- Fire Access Standards

Chapter 17.57: Landscaping and Chapter 17.58: and Trees

Landscaping, tree coverage, and tree preservation are all integral components of a complete comprehensive development plan. The purpose of Chapters 17.57 and 17.58 are to both encourage and require the use of landscape elements, tree planting, and tree preservation within new developments that will enhance, protect, and promote the economic, ecological and aesthetic environment of McMinnville.

These chapters address standards for landscaping and street tree planting plans for new development and land divisions, and they address tree preservation for development sites. These standards would apply to development upon annexation of property to the City. The purpose statement of Chapter 17.57 summarizes some of the key objectives of the standards.

1. Reduce soil erosion and the volume and rate of discharge of storm water runoff.
2. Aid in energy conservation by shading structures from energy losses caused by weather and wind.
3. Mitigate the loss of natural resources.
4. Provide parking lot landscaping to reduce the harmful effects of heat, noise and glare associated with motor vehicle use.
5. Create safe, attractively landscaped areas adjacent to public streets.

6. Require the planting of street trees along the city's rights-of-way.
7. Provide visual screens and buffers that mitigate the impact of conflicting land uses to preserve the appearance, character, and value of existing neighborhoods.
8. Provide shade, and seasonal color.
9. Reduce glare, noise, and heat.

4.5 PLAN UPDATES

The above information summarizes key provisions of plans and polices which are adopted as part of the Comprehensive Plan. As noted above, the City has also initiated updates to elements of the Comprehensive Plan, including those noted below. The work on this and other Area Plans will also inform coordination with that work.

- Natural Hazards Planning (Oregon Land Use Goal 7) several plans and updates
- Natural Features Planning (Oregon Land Use Goal 5)
- Parks, Recreation, and Open Space Master Plan Update
- Public Facility Plan Updates (water, wastewater, stormwater)
- Transportation Systems Plan (TSP) Update

5.0 FINDINGS AND KEY ISSUES

A summary of study area plan implications, based on the existing conditions, are provided below:

Land Use and Zoning

- The Fox Ridge Road Area Plan is expected to be adopted in reference to the MGMUP to ensure the study area complies with the goals and objectives established through the area planning process
- A significant land use within the area will be the 41-acre site owned by McMinnville School District that is slated for the potential development of a future high school.
- The plan will include a Neighborhood Activity Center that allows for small scale commercial and office development, NAC park/plaza, and high-density residential development within the center.
- The Neighborhood Activity Center should be strategically located to provide services and amenities to the diverse residential developments proposed within the study area.
- A neighborhood park is to be located within ½ mile of all residences within the neighborhood.

Natural Features

- Topographically, the majority of the study area consists of gradual to steeply sloping land that may affect the constructable residential densities and related utilities.
- A majority of the area's soils are of moderate to poor permeability which limits the types of stormwater facilities that can be utilized in support of future urban development.
- The area plan will need to plan for a useable open green space network that includes greenways and trails throughout the area to improve the walkability and accessibility of the study area.
- Two ridges running parallel to Fox Ridge Road, one on the north side and one to the south, further divide the properties along Fox Ridge Road from flatter areas at the northeast corner of the study area and land immediately to the south.
- Recent mapping conducted by the City of McMinnville to identify natural hazards and natural features in conjunction with Statewide Planning Goals 5 and 7 identified significant tree groves

at the western edge of the study area, and scenic viewpoints along ridgelines to the north and south of Fox Ridge Road. It will be important to conserve natural greenspaces and greenways that may also serve to protect the dense stands of mature trees that provide habitat for protected avian species.

- Relatively flat properties at the northeast corner of the study area and at the base of Fox Ridge Road, near its intersection with NW Hill Road, are less impacted by slopes and closer to existing utilities.
- A large remainder of land within the Fox Ridge Road Area Plan is most suitable for lower density residential housing development due to steep slopes.
- Preliminary mapping of potential NH-P and NH-M overlay zones indicate that development may be limited by natural hazards on the middle portion of Fox Ridge Road, above the cemetery and tree farm properties at the base of the hill, and below the westernmost edge of the study area. In combination with other development constraints (parcelization, serviceability), new residential development along the higher portions of Fox Ridge Road may take place later than other portions of the area, or at a lower intensity. These areas could be evaluated in conjunction with identified natural features and habitat areas for possible designation of open space areas and/or transfer of development rights.

Infrastructure and Services

- If a different street standard is applied to Fox Ridge Road, future development would require road frontage improvements to meet City standards, including improvements to the right-of-way, remove and reconstruction of the existing subgrade, construction of paved travel surfaces, as well as 5-foot minimum sidewalks along both sides of the street, curbs and gutters.
- Connectivity and coordination with the development of the high school site, adjacent to the proposed mixed-use concept plan development, will be critical to the area plan.
- Bike and pedestrian connectivity should occur between the Fox Ridge Road area and existing trails and linear parks throughout McMinnville.
- Coordination with Yamhill County Transit should occur to provide public transit services, especially in conjunction with the proposed partial Neighborhood Activity Center location.

Wallace Road Extension

- The three-legged roundabout at the intersection of NW Hill Road and Wallace Road provides an opportunity to extend Wallace Road westward for access to the location of the Neighborhood Activity Center and the McMinnville School District property.
- A Wallace Road extension would provide access for the future high school site and the Neighborhood Activity Center on TL 700. Due to these adjacent uses, the Wallace Road extension will likely be the most used street in the study area, by all modes of travel, making the design and alignment of the road particularly important.

Regulatory Context and Planning Framework

- The Area Plan will be adopted as a supplement to the McMinnville Comprehensive Plan, and act guide for future urbanization of the land located within the Fox Ridge Road Area Plan.
- The Area Plan will reflect the principles of the MGMUP, MGMUP Framework Plan, McMinnville Comprehensive Plan and other applicable City land use policies and standards including:
 - The guidelines of the Traditional Neighborhood model
 - Standards for a partial Neighborhood Activity Center
 - The adopted Great Neighborhood Principles (Comprehensive Plan Policies 187.50)

- The MGMUP Framework plan identifies potential planned uses such as a partial or half Neighborhood Activity Center (5 – 10 acres) with commercial and office development (1 – 2 acres), medium-density residential development (2 – 5 acres) and high-density residential development (2 acres) located at the perimeter of the Neighborhood Activity Center. This will also include a Neighborhood Park located within a ½-mile distance from all residences in the study area, and a natural resource park.

School District Property

- McMinnville School District owns a 41-acre site at the northern edge of the study area, intended for a future high school. The site is a parallelogram, extending only about 700 feet in depth from the anticipated future extension of Wallace Road.
- The future high school site occupies a significant portion of the flat land at the northeast corner of the study area that is most easily accessed and serviced by existing utilities. Depending on the size of the high school, utility needs may vary. The timeline for development is uncertain.
- The district has not adopted specific programming or plans for a high school at this time, pedestrian, bicycle, and vehicular connectivity to the school will need to anticipate the future layout of the site.
- The shape of the property may pose challenges for configuring a high school, depending on the eventual programming intended for the facility.

Other Permanently Occupied Sites

- Two of the larger properties within the southern portion of the study area are occupied by uses that have been committed to specific uses that make them unlikely to redevelop at any time in the future:
 - The Masonic Cemetery occupies a 21-acre site, occupying nearly 70 percent of the southern boundary of the study area.
 - McMinnville Water and Light owns 13-acres near the center of the study area, along Fox Ridge Road, that houses four above-ground water reservoirs.
- These sites do not directly impact the development potential of neighboring properties but could interrupt the continuity of annexation and utility extensions, as property is urbanized from the existing City limits at the base of the hill. Annexations contiguous to City limits could occur relative to the City limits to the east or the south.

Rock Quarry Pond

- A large gravel quarry, now filled with water, is centrally located within the study area, near the base of Fox Ridge Road and adjacent to the approximate location suggested in the Framework Plan for the Neighborhood Activity Center. The gravel pit currently stores runoff from uphill lands and provides supplemental irrigation to properties outside of the study area.
- The pond created on the gravel pit site could provide a feature to a future park site or amenity for development in the vicinity.
- A park site or public park at the gravel pit site would occupy a possible connection point between the higher ground along Fox Ridge Road and potential future locations for a high school and Neighborhood Activity Center. However, the pond itself is not visible from either of these lower elevation sites.
- The pond currently plays a role in stormwater drainage and retention, and changes in configuration may have impacts in and around the site.

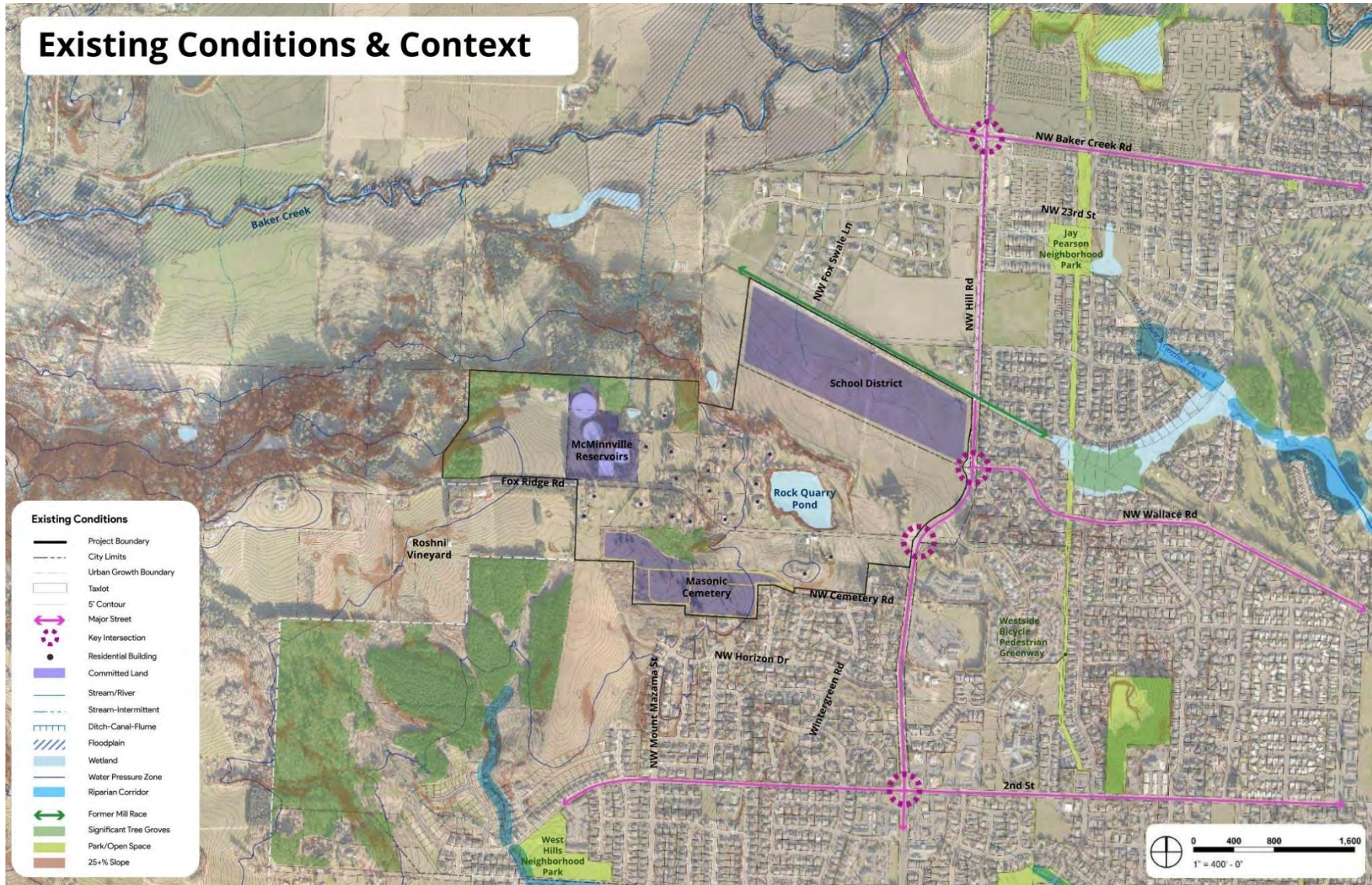

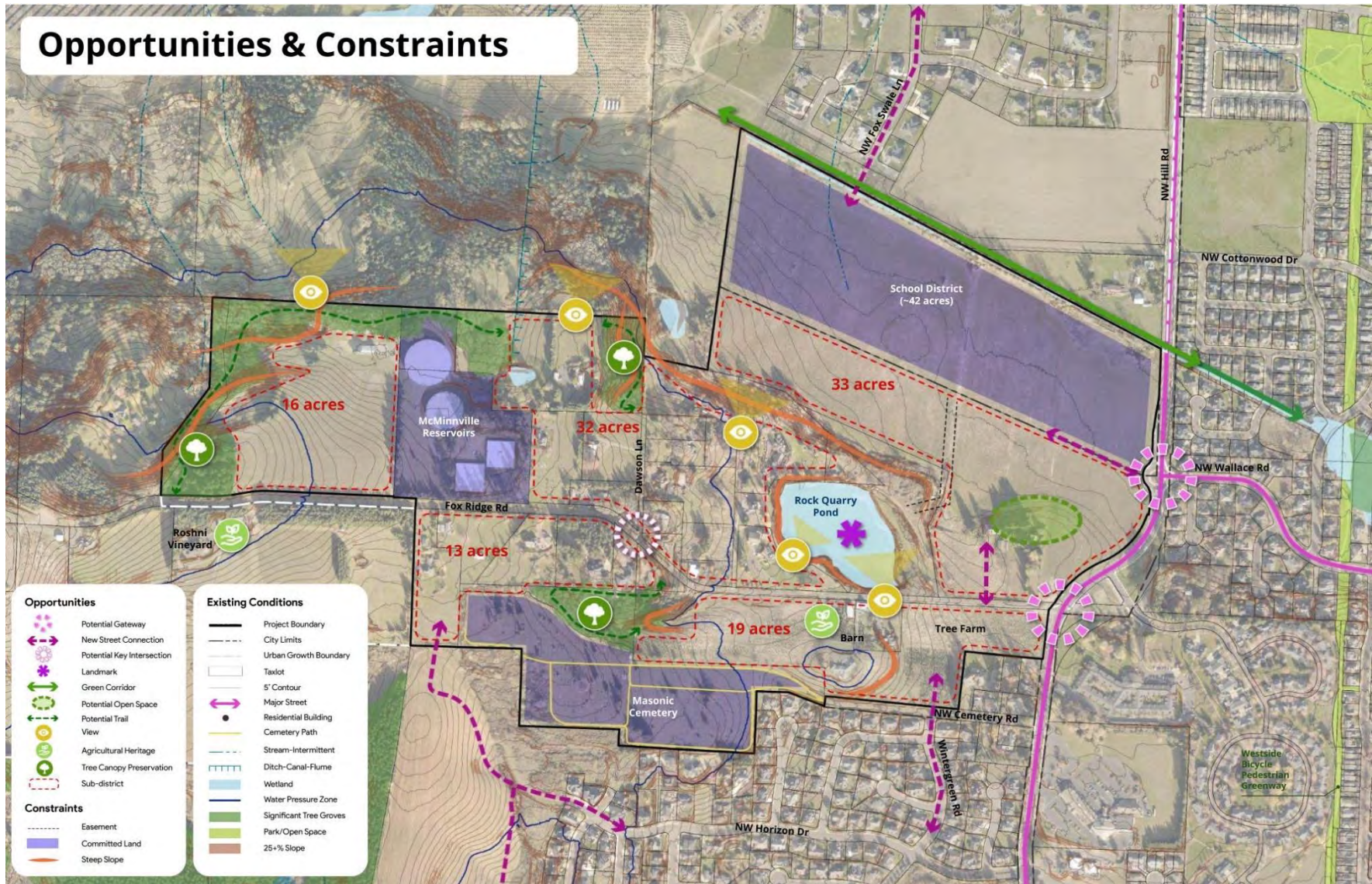

APPENDIX B

FOX RIDGE ROAD COMMUNITY SURVEY SUMMARY

City of McMinnville Fox Ridge Road Area Plan



Harper
Houf Peterson
Righellis Inc.

ENGINEERS ♦ PLANNERS
LANDSCAPE ARCHITECTS ♦ SURVEYORS
205 SE Spokane Street, Suite 200, Portland, OR 97202
PHONE: 503.221.1131 www.hhpr.com FAX: 503.221.1171

Date: April 13, 2023

To: Tom Schauer, City of McMinnville

From: Chris Green, HHPR

Subject: Fox Ridge Road Community Survey Responses and Summary

QUESTION 1 – How are you familiar with the Fox Ridge Road Area? [146 responses]

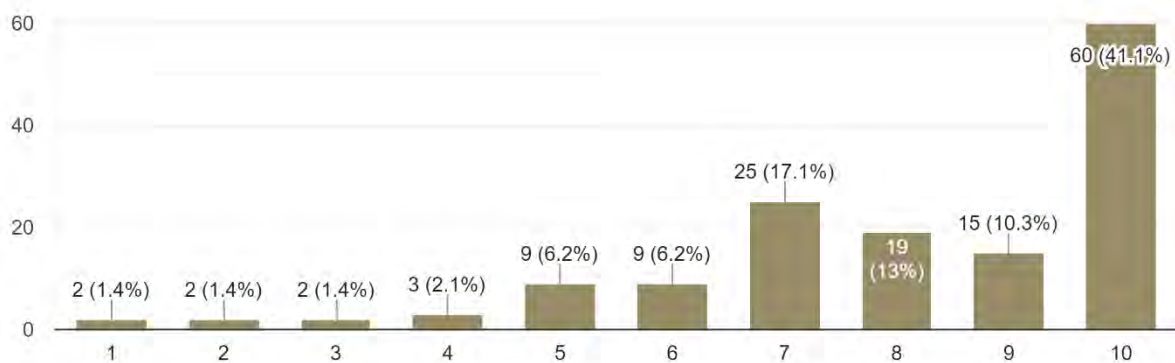

QUESTION 2 – What is your relationship to the Fox Ridge Road Area? Select all that apply. [147 responses]

[147 responses]

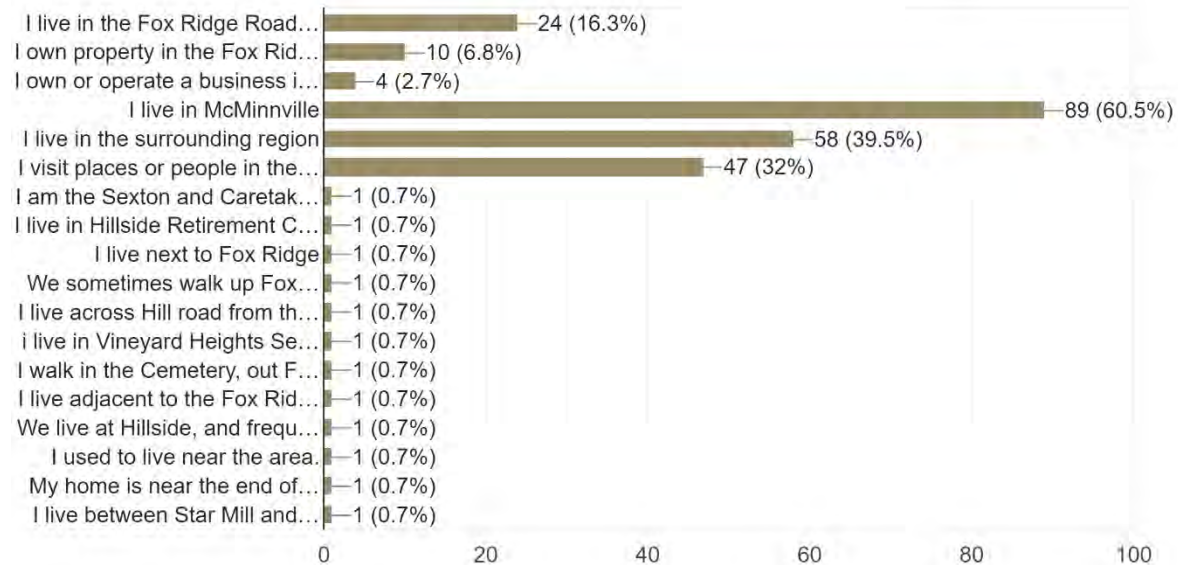

QUESTION 3 - Imagine 20 years from now there are new neighborhoods and features in the Fox Ridge Road Area, as shown on the Framework Plan. What would you like to see? [143 responses]

- Parks/trails/open space
- Housing (wide range of opinions on density/affordability)
- Neighborhood-serving retail
- Preserving views

Many of the responses from residents included reoccurring themes such as the need for additional community spaces, achieving walkability with appropriate neighborhood retail development and the need for green open spaces incorporated throughout the area plan with connecting trails and pedestrian passages. Generally, those who participated in the survey want to see walkable neighborhoods that eliminate the need for cars, as there is an already existing concern for traffic in the surrounding area. The wide range of housing opinions included the preservation of low-density housing to the inclusion higher density, multi-unit housing options that are affordable for residents. Many survey responses mentioned the location of any medium to high-density housing developments should remain in or near the proposed Neighborhood Activity Center area at the intersection of Fox Ridge Road and Hill Road. Several responses also mentioned the need for a grocery store in the area to serve the existing and any new neighborhood residents and prevent additional traffic impacts. In addition to a grocery store or neighborhood-serving retail, most responses to this question have mention of parks, open space, and trails to make the area more walkable and accessible. Many residents of McMinnville walk within the area, and with observed increases in surrounding traffic, responses appear to prioritize the walkability of the neighborhood. Recreational opportunities and community spaces were also mentioned in several responses.

The responses from residents who live in the Fox Ridge Road Area highlighted the preservation of open space and natural habitats that currently exist or surround the area, especially the scenic views that the area's higher elevation is able to afford. More specifically, residents who live in the Fox Ridge Road Area would like to see careful attention to architectural features and details for any new development, as there were mixed responses regarding the density of housing for the area. Some examples of specific features include parkway and landscaping, requiring undergrounded utilities to preserve the scenic landscape, or the requirement of architectural standards that may break up building planes, add neighborhood character and preserve the unique features of the area.

Question 4 — As this area transitions from rural to urban uses over time, are there assets or distinctive features within the area that you think should be conserved and/or incorporated into the plan? [136 responses]

- Impacts on nature, wildlife and mature tree stands
- Preservation of rural lifestyle, local views
- Conservation of rock quarry, masonic cemetery and tree farms
- Incorporate community parks, green spaces as buffers

Generally, many responses to this question pose a concern for impacts due to urban development. Many of the responses have the same themes that include the preservation of nature, wildlife, and the areas rural charm and lifestyle. Distinctive features of the area were notably the existing dense

tree stands, open rural land, and several responses specifically mention the conservation of the rock quarry with potential use as a community park, as well as the existing masonic cemetery. Along the theme of rural preservation, new commercial development was suggested to be appropriate for the area in scale and use, such as small-scale or multi-use retail development with attention to architectural features. Residents also mentioned creating buffers between development of neighborhoods with green spaces, preserving existing trees that line the area and provide natural habitat for wildlife. This also includes the incorporation of open green spaces throughout the majority of the Fox Ridge Road Area Plan.

Question 5 — What else should we know or consider as we move forward with the Fox Ridge Road Area Plan? [116 responses]

- Traffic impacts
- Walkability and pedestrian/bike paths
- Open green spaces
- Various opinions about housing affordability
- Concerns for new development density, utilities and aesthetics

Moving forward with the Fox Ridge Road Area Plan, residents expressed their concerns for traffic impacts from new urban development. There is existing concern for traffic near the roundabout on Hill Road, and the general increase of traffic on Hill Road. Responses specified consideration to traffic impacts as the plan moves forward, with suggestions on how to mitigate existing and new traffic conditions. Much of these suggestions also revolve around increasing the walkability of the area through the inclusion of carefully planned pedestrian and bike paths that connect the existing features of the Fox Ridge Road area. These connections were also suggested to include neighborhood green spaces in order to consider connectivity between open space and any new development. Especially considering the potential future development of the high school site, residents expressed further concern for traffic impacts and circulation along Hill Road.

There were also many varying opinions about housing affordability, whether or not new units should be market rate or primarily affordable. Some responses expressed the need for affordable housing options for residents within the City of McMinnville, while others expressed concerns for density and a desire to preserve the rural nature of the area. Overall, there is consistent responses regarding the overall density of new units in their appearance, ensuring that any new development does not appear to be out of place from the existing neighborhood character. When discussing medium to high-density developments, considerations to new utilities and their impacts, and overall aesthetics were noted. The survey responses emphasize community and neighborhood-oriented development for residents of Fox Ridge Road the surrounding area.

Memorandum



Date 3/28/2023
Project Name Fox Ridge Road Area Plan

To Chris Green, HHPR
cc Tom Schauer, City of McMinnville
From Margaret Raimann, SERA Design

Subject Fox Ridge Road Area Plan Community Design Workshop #1 Summary

As part of the planning process for the Fox Ridge Road Area Plan, the City of McMinnville hosted a community design workshop on March 21st, 2023 from 6 to 8 p.m. SERA Design led the workshop with assistance from the prime consultant on the project, Harper Houf Peterson Righellis Inc. (HHPR). The purpose of the workshop was to present the findings from the opportunities and constraints analysis and gather feedback from community members on the preferred development scenarios for the Fox Ridge Road area. Over 50 people attended and participated in the design workshop, and community members also have an opportunity to provide input through a survey open through April 10th, 2023. This memorandum summarizes the workshop event and the key themes that emerged from the community input.

Workshop Summary

The format of the workshop included a 30-minute presentation with an opportunity for questions from community members. The City of McMinnville and HHPR started the presentation with an introduction to the project and previous planning efforts that led to the development of the Fox Ridge Road Area Plan. They provided an overview of the consultant team and the project phases. This event was the first of two community design workshops with the first focusing on development scenarios and the second focusing on plans for parks, open space, and connectivity.

SERA Design presented background information that helped to guide community members in the workshop activity following the presentation. This section of the presentation included an overview of potential development typologies for the area; land use guidelines provided in the Fox Ridge Road Framework Plan; an overview of existing conditions in the area; and a draft of an opportunities and constraints area for consideration in the development scenarios. Prior to starting the small-group workshop activity, community members were welcomed to ask questions to help clarify the purpose and potential development scenarios.

Following the presentation, City staff and the consultant team facilitated small-group discussions in table groups with about 8-10 community members at each table. Each table was provided with a map of the Fox Ridge Road area, precedent imagery with potential development typologies, and tools for drawing and envisioning the location of land uses for future development. Facilitators asked questions to guide the discussion including:

- Are there opportunities or constraints we missed in the draft map?
 - What opportunities are you excited about?
 - What other ideas do you have for this area?
- Given the opportunities and constraints where would you like to see the following land use development typologies?
 - High-density residential
 - Medium-density residential
 - Low-density residential
 - Neighborhood-service commercial / office
 - Parks / open space

After about one hour of small group discussions, the workshop concluded with a representative from each group sharing a few ideas with all workshop participants. The key themes that emerged from the workshop activity are summarized in the next section, and images of each map that the groups produced are provided in Appendix A. Community Design Workshop #1 Notes.

Key Themes

The key themes that emerged from the community design workshop are summarized below. The project team will use these themes to guide the draft development scenarios and further discussions with the Project Advisory Committee.

- **Offer a range of housing types.** The Framework Plan outlines minimum acreages for medium and high-density housing. Some groups stated they preferred to meet the minimum acreage for these housing types while other groups proposed exceeding these minimums. One rationale given for exceeding these limits was to bring a greater variety of housing density to an area of McMinnville with existing residential densities that are generally lower than other areas of the city.
- **Locate medium higher density housing types near eastern boundary of area.** Most groups agreed that the medium and high-density housing types would fit best along Hill Road or other areas along the eastern boundary of the Fox Ridge Road area, given physical constraints and limited capacity of Fox Ridge Road.
- **Focus on design of new development.** Many groups raised concerns about creating well-designed developments with the new housing proposed for this area. They asked whether certain design standards could apply to the planning area to ensure this goal is achieved.
- **Connect open spaces.** This area will include substantial acreage for parks and open space due to the constraints that may restrict development and overall community need for more areas for recreation. The workshop participants suggested that the open spaces should also be connected via greenways and include connections to the existing multimodal network in the City of McMinnville. Open green spaces were suggested to preserve existing community resources including the masonic cemetery, rock quarry pond, and key viewpoints. Many groups proposed that the neighborhood park should be accessible by a range of residents living in all housing types. The second community workshop will focus on open spaces and will provide another opportunity for the community to provide input.
- **Consider traffic impacts of new development.** Many of the concerns related to increased development along Hill Road focused on increased traffic demand and the existing function of intersections along Hill Road that border the area. A future task of this planning effort will include analysis of transportation infrastructure and an identification of needs for the preferred development scenario.
- **Provide alternative access and connectivity.** Related to the traffic concerns, some groups suggested alternative access points to reduce demand on Hill Road and Fox Ridge Road. Community members raised concerns about the existing capacity and condition of Fox Ridge Road as a narrow right of way with sight distance issues and no shoulders. Future work on this project will include a more detailed look at these potential connections as well as another opportunity for the community to provide input on this topic.

Next Steps

The next step in this process is for the SERA team to develop the draft development scenarios based on the community input provided in the design workshop and the survey (open through April 10th). City staff and the Project Advisory Committee will provide further input on the development scenarios, leading to a preferred scenario for the Fox Ridge Road Area Plan. The community will have another opportunity to provide feedback at the second community design workshop in June 2023.

Memorandum

APPENDIX A. COMMUNITY DESIGN WORKSHOP #1 NOTES

This appendix includes images of notes taken on maps for the small-group activity at the March 21, 2023 workshop.

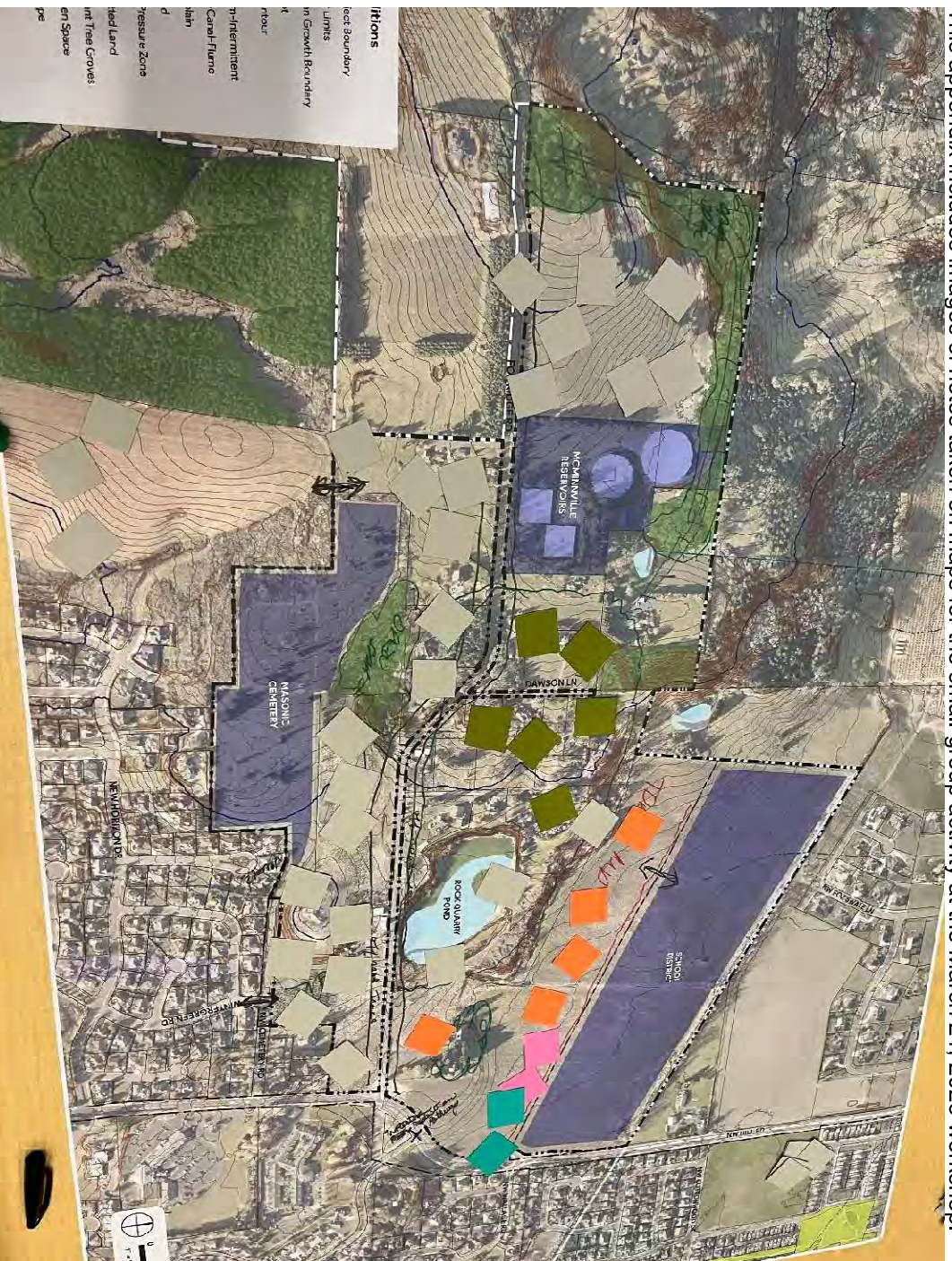

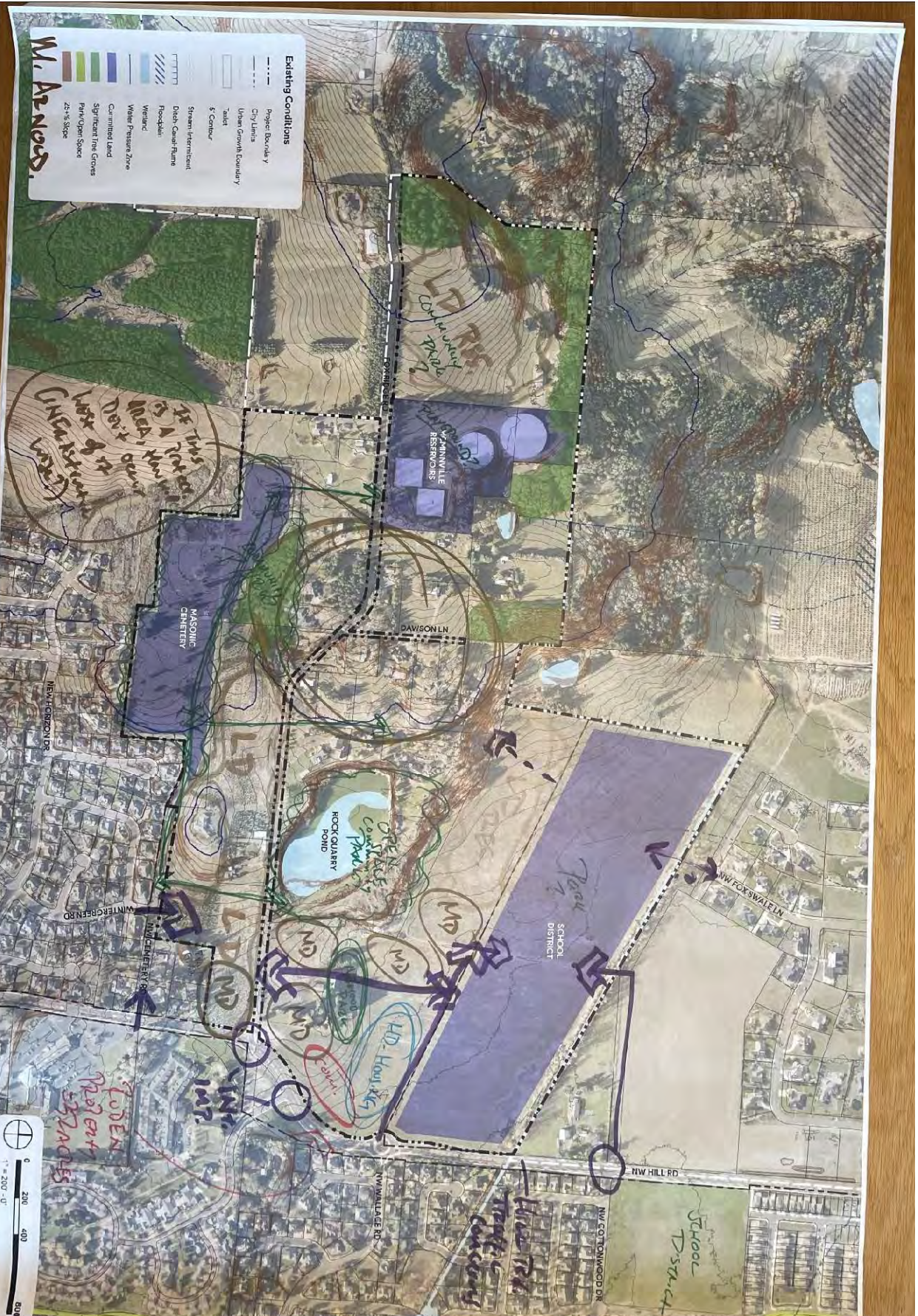



Opportunities & Constraints

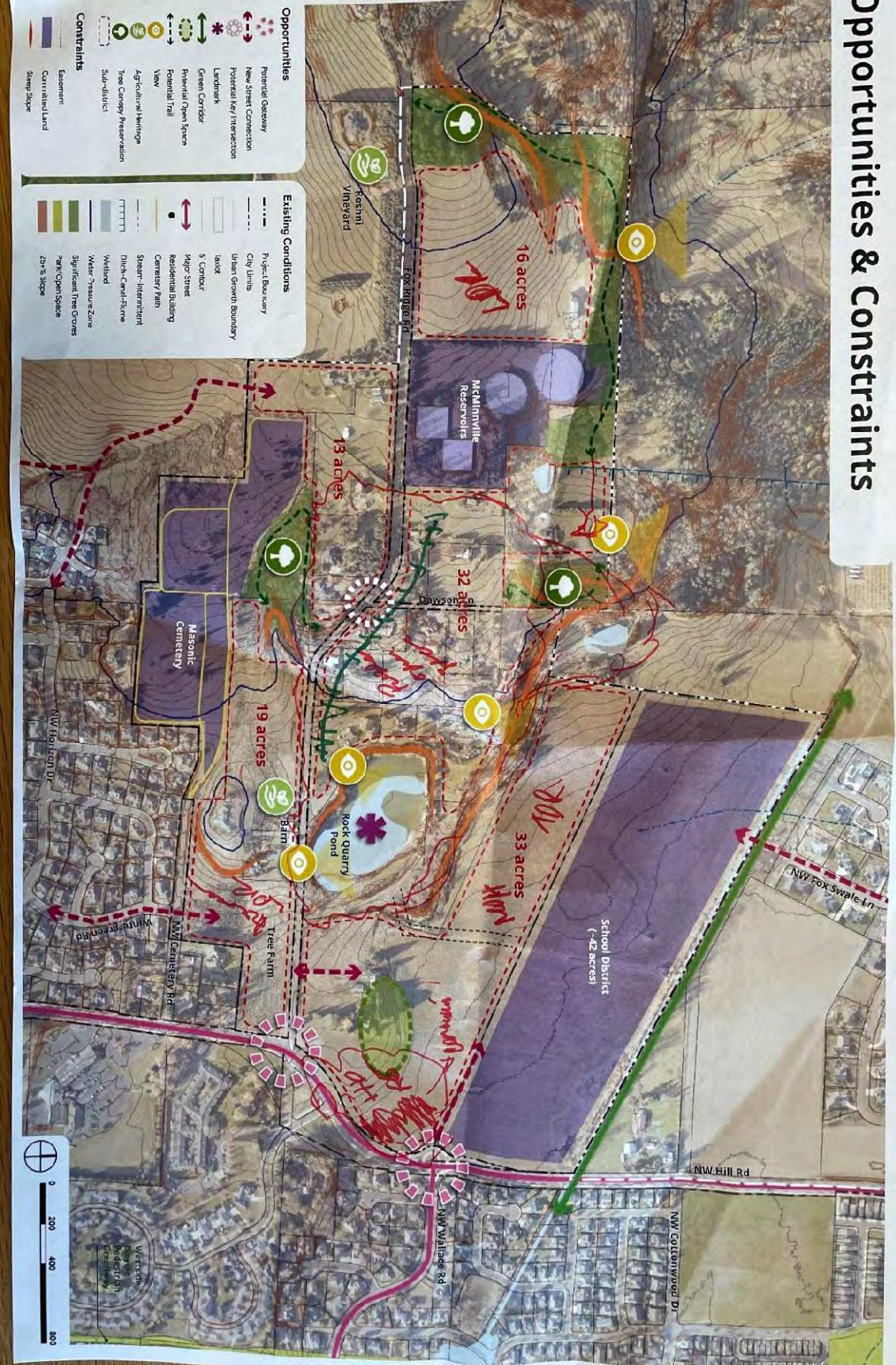

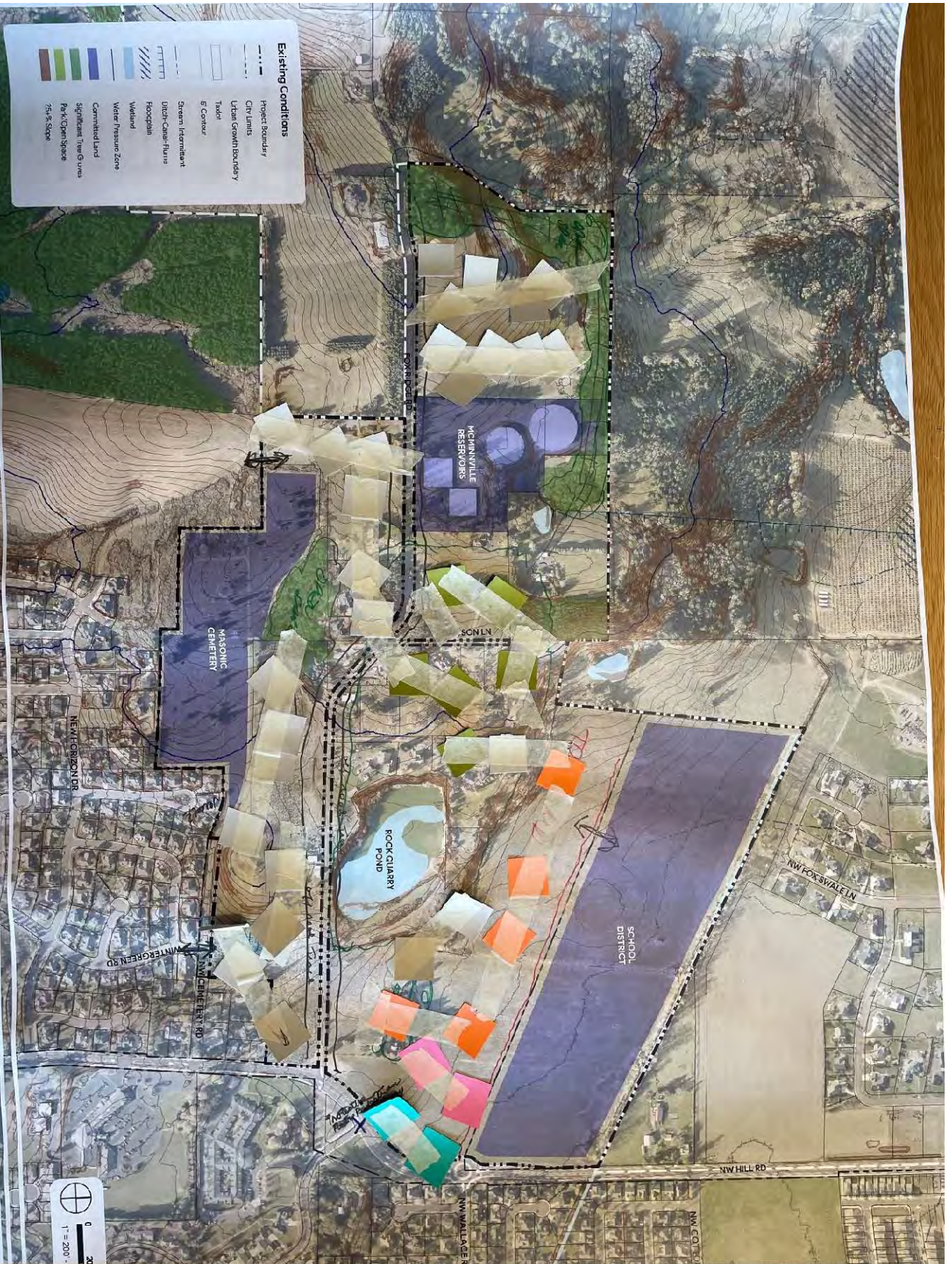

City of McMinnville
Fox Ridge Road Area Plan
Memorandum



ENGINEERS ♦ PLANNERS
LANDSCAPE ARCHITECTS ♦ SURVEYORS
205 SE Spokane Street, Suite 200, Portland, OR 97202
PHONE: 503.221.1131 www.hhpr.com FAX: 503.221.1171

Date: June 14, 2023
To: Tom Schauer, City of McMinnville
From: Chris Green, HHPR
Subject: Community Design Workshop #2 Summary

COMMUNITY DESIGN WORKSHOP #2

On June 6, 2023, City of McMinnville hosted a second Community Design Workshop to gather feedback on opportunities for potential park sites and connection points in the Fox Ridge Road Area and begin developing concept plans for future parks, trails, and connections. Planners and landscape architects from Harper Houf Peterson Righellis Inc. (HHPR) led the workshop with assistance from City staff. Over 30 people attended and participated in the design workshop. Building from the workshop feedback and land use concepts developed in the first Community Design Workshop (March 21, 2023), the project team will develop concept plans for future parks, trails, and connection opportunities in the Fox Ridge Road Planning Area. This memorandum summarizes the workshop event and the key themes that emerged from the community input.

WORKSHOP FORMAT

The format of the workshop included a 30-minute presentation by HHPR with opportunities for questions from community members. Workshop attendees were presented with the background of the project, the project timeline, goals, and the purpose of the workshop. Following the presentation, the consultant team and City staff facilitated small-group discussions with about 8-10 community members at each table.

Each table was provided with one base map of the draft preliminary land use concept for the Fox Ridge Road area, one base map of the neighborhood activity center (focused on the neighborhood park site identified in the preliminary land use concept), and smaller maps for reference of the opportunities and constraints, existing conditions, and natural hazard overlays of the area. Tools such as markers, trace paper, and sticky notes were provided for participants to draw and annotate the base maps with suggestions for future parks, trails, open space and connections within the Fox Ridge Road area. Facilitators guided the small groups through two exercises with 30 minutes allocated for each exercise. The first group exercise focused on looking at the neighborhood park centered within the neighborhood activity center, ensuring that the park was both well-connected and accessible. The second exercise focused on open space and trail opportunities throughout the overall Fox Ridge Road area based on the draft preferred land use concept map, including potential features and linear parks. Both exercises sought out input for suggested amenities and important features to preserve in the area plan.

After discussion, a representative from each small group shared their ideas with all workshop participants for consideration. The workshop concluded with final questions from the community and a regroup of the PAC to review the results of the community design workshop.

KEY THEMES

The key themes that emerged from the community design workshop are summarized below. Images of each annotated map produced by the workshop groups are provided in Appendix A. The project team will use these themes to guide the park, trails, and open space concepts for the area.

Neighborhood Park

- **Pedestrian connections.** Among all the groups, bike and pedestrian friendly connections were agreed to be a priority of the neighborhood park. These pathways were discussed as pedestrian only connections and accessible for all age groups and uses such as bikes, pedestrians, strollers, and wheelchairs. All groups also mentioned that these connections should connect the proposed residential units adjacent to the neighborhood park within the neighborhood activity center, as well as the school district site and Fox Ridge Road area. However, it was also discussed that the neighborhood park should primarily serve the community within the neighborhood itself.
- **Community gathering area.** Most groups mentioned the need for a community gathering area or space within the neighborhood park. Ideas that were proposed include a large gazebo, auditorium built into the topography of the park landscape, or other picnic and barbeque areas for community members to gather.
- **Amenities.** Each group had their recommendations on different amenities that should or needed to be provided. Restrooms and potable water stations were considered necessary within the park, and other recreational amenities were suggested such as smaller sport courts (tennis, basketball, pickle ball, etc.), casual outdoor games (horseshoe, bocce ball, etc.), large children play areas and play structures, shade structures, and even a bicycle repair station was proposed for passing bicyclists. All groups notes that amenities should be accessible to all age groups and provide diverse uses in activity types.
- **Tree preservation and shade trees.** There are many existing mature trees within the proposed neighborhood activity center area, which each group noted as an important natural feature of the area and should be made as a priority to preserve as many mature trees as possible. The additional planting of shade trees was also mentioned as another priority of the neighborhood park. Additional tree planting would not only provide shade but also a buffer to the surrounding residential uses as well.
- **Community garden.** Several groups mentioned using available open green areas as community garden space for the neighborhood activity center. Specifically, for residents who may live in future medium- to high-density residential units that may not have access to private yard space.
- **Traffic safety/traffic calming on surrounding streets.** Among the largest concerns for the neighborhood park was traffic safety and parking. Many groups voiced their concerns with the existing traffic issues within the area and expressed that those issues should not be exacerbated by visitors to the neighborhood park. Several groups expressed that no parking or parking lots should be proposed for the park and that access to the parks should be primarily through pedestrian connections.

Other Opportunities for Parks, Trails, Open Space, and Connectivity

- **Pedestrian connections.** Most workshop groups shared that pedestrian and bike friendly connections are a priority for the Fox Ridge Road area. These proposed trail or pathway connections should provide safe access to all users and connectivity to both the Fox Ridge Road area and the surrounding neighborhoods. Groups discussed the concept of a trail or sidewalk connection along Fox Ridge Road further, and many groups proposed a pedestrian connection

further south, at the north boundary of the Masonic Cemetery rather than along Fox Ridge Road itself, due to traffic safety concerns along the roadway.

- **Trails and viewpoints.** All groups were asked to consider natural trails and open spaces throughout the project area, with many groups agreeing with the proposed location of trails along the northern boundary and connecting back to the neighborhood activity center to the east. Many groups emphasized prioritizing the viewpoints along the trail loop at the northern end where expansive views of McMinnville can be seen and enjoyed by the community. Amenities such as trail benches for seating and potable water stations were recommended at these scenic viewpoints. Some groups also suggested that north to south connections should be considered throughout the project area, especially for the areas marked for low-density residential north of Fox Ridge Road in order to connect the trails back to the public street system and provide varying levels of trail opportunities.
- **Park around the Rock Quarry.** Each group considered the rock quarry pond for possible preservation as a notable natural feature, or even for development as a natural park space with a trail surrounding the pond, with access to the area from both Fox Ridge Road and the bottom of the slope where the neighborhood activity center is proposed, and some smaller amenities such as benches for additional seating opportunities. Some groups expressed safety concerns about topography around the pond, both for accidents around the water and lack of visibility to allow monitoring from other public spaces.
- **Preserve natural topography.** Along with the preservation of natural features, the general topography of the area was discussed and favored for preservation. Ensuring that the land is not graded in a way that diminishes the natural landscape and that park or open spaces work to preserve that topographical feature.
- **Traffic safety and parking.** Again, among the largest concerns for the area was traffic safety and parking. Many groups voiced their concerns with the existing traffic issues along Hill Road and Fox Ridge Road, stating that drivers not only exceed the speed limit creating dangerous conditions, but also the increasing traffic impact of congestion to the area. Many groups emphasized that pedestrian connections through linear parks and trails should be utilized to encourage access to the area, rather than parking lots that would only increase existing traffic issues and concerns. Specifically along Fox Ridge Road, groups agreed that any potential park features at the top of Fox Ridge Road to the west should be very careful about providing parking, if any, at all.

NEXT STEPS

- Project Advisory Committee (PAC) Meeting #3 – June 21, 2023
- Project Advisory Committee (PAC) Meeting #4 – August 2, 2023

ANNOTATED BASE MAP NOTES

[Refer to Appendix A]

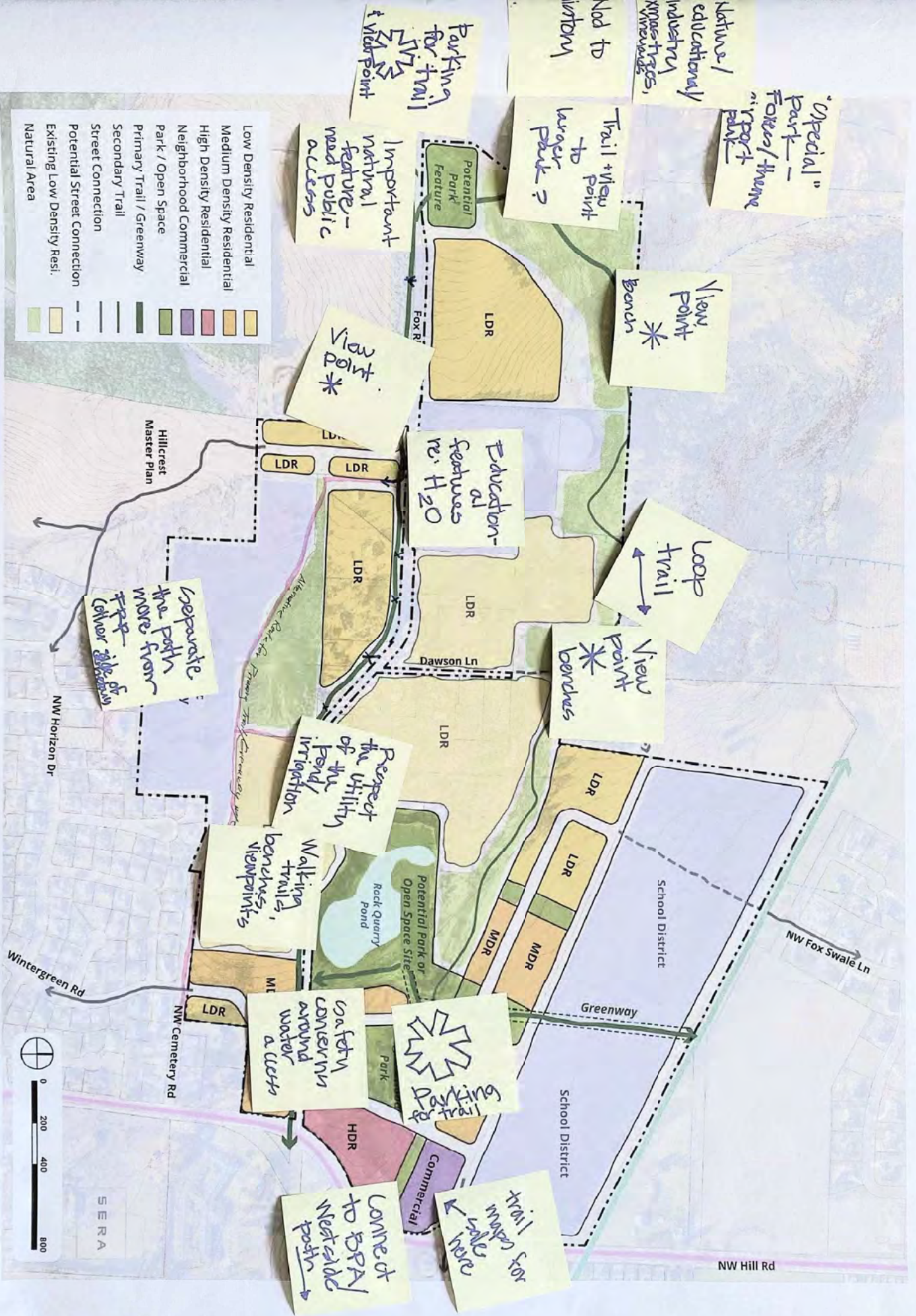

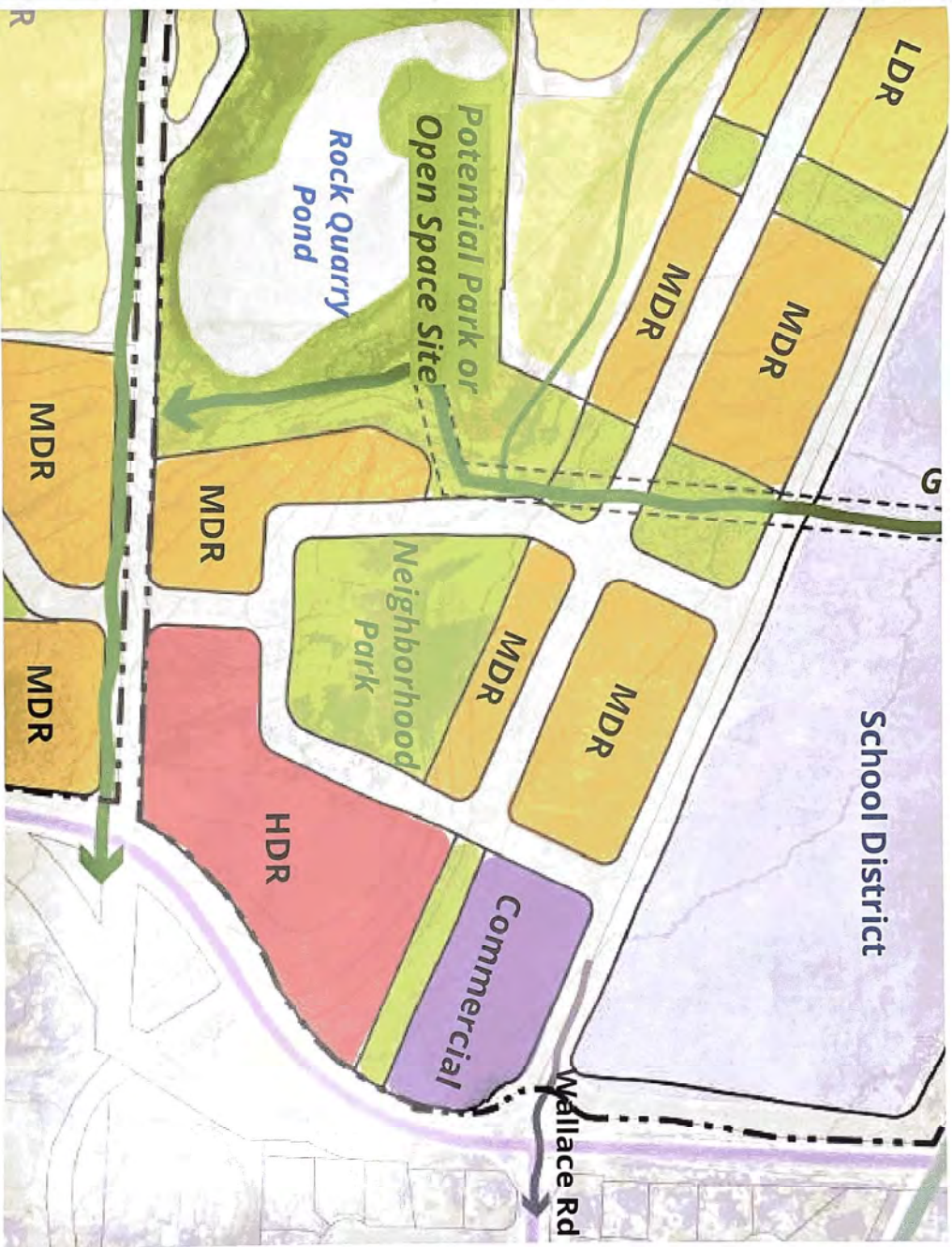

- MIXED AGE / MIXED AGE ACTIVITIES

- WATER FEATURES
- VIEW OF M.D.
- DOGS PARK
- BASKET BALL
- PLAYGROUND
- PICKLE BALLS?
- GARAGE
- TREES / SHADE
- OUTDOOR ROOMS / PICNIC
- SAFE PLAY/STORAGE (BAG)
- AS BIG AS POSSIBLE
- WIDE STREETS / SAFE STREET
- VAULT PARKS / LITTLE ROOMS
- MULTIPLE DECK AND AWNINGS VS. A SINGLE LARGE SPACE
- CUMBRINGS
- REST ROOMS
- HOUSE SHOP

SAFETY
FOR
MULTI-USE
ROADS

GREENERY
ALONG
ROADS

WORK
WITH
RIDGE
LINES +
TOPOGRAPHY

SOUTHWARD
CONNECTIONS

SETTING
ALONG
PARTS

POTABLE
WATER

ACCOMMODATE
DATE
THROUGH-
FARES,
SHOOTER LOOPS

SLOW/
MINIMIZE
TRAFFIC

GREEN
LINER
PARKS
ALONG
HILL

EASEMENTS
FOR
PEDESTRIAN
USE
ALONG
ROADS

AMEND
MDR TO
HDE.
EXPAND
PARKS

Idea: Make the MDR next to the
neighborhood park into a part of the park.

- Low Density Residential
- Medium Density Residential
- High Density Residential
- Neighborhood Commercial
- Park / Open Space
- Primary Trail / Greenway
- Secondary Trail
- Street Connection
- Potential Street Connection
- Existing Low Density Resi.
- Natural Area

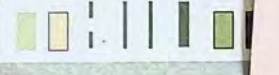

SERA



QUARRY

- WALKING LOOP
- COMMUNITY MEETING SPACE
- VIEWPOINTS
- SEATING/BENCHES
- MORE OF AN OPEN SPACE/NATURAL

SAFETY

- BIKE-FRIENDLY PATHS (STROULEAS, ETC.)
- CONNECTIVITY (PROMOTE NON-AUTO.)
- PRESERVATION OF NATURE, EXISTING TREES
- PARKING THAT IS APPROPRIATE FOR THE NEIGHBORHOOD/VISITORS PROJECTS
 - TO SCALE
- COLLABORATION WITH LOCAL ORGS. (EDIBLE LANDSCAPES, ETC.)
- COMMUNITY GARDEN
- MULTI-GENERATIONAL APPEAL
 - BOG PARK
 - SKATE PARK
 - AMPITHEATER, MUSIC
 - MOVIE NIGHTS, SPACES FOR MAINTAIN OPEN SPACES FOR MULTI-USE
- UTILIZE SMALLER GREENSPACES
 - POSSIBILITY FOR SMALLER SCHEMATA
 - EMPHASIS ON AREAS NEAR HDR
 - PLAN FOR FUTURE SHADE TREES
 - LOW-INTENSITY / IMPACT PLANTINGS
- PICNIC TABLES
- BATHROOMS, WASTE MANAGEMENT, WATER FOUNTAIN
- BIKE REPAIR STATION
- COMMUNITY-BASED ART INSTALLATIONS
- COMMUNITY/CENTRAL MEETING LOCATIONS
- GREEN SPACE PROPORTIONED TO MAX. DENSITY

- Low Density Residential
- Medium Density Residential
- High Density Residential
- Neighborhood Commercial
- Park / Open Space
- Primary Trail / Greenway
- Secondary Trail
- Street Connection
- Potential Street Connection
- Existing Low Density Resi.
- Natural Area

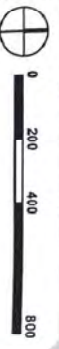
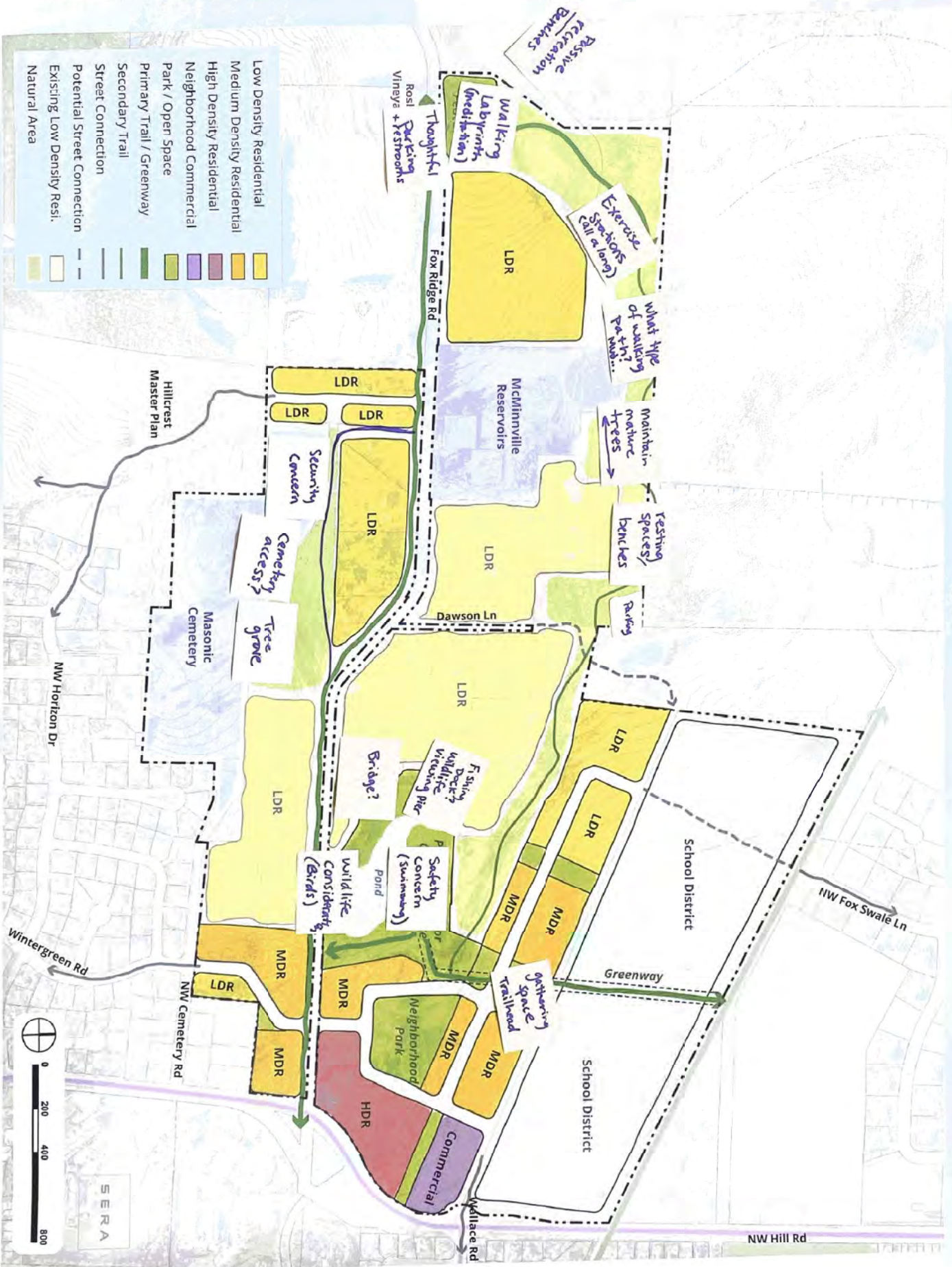

SERA

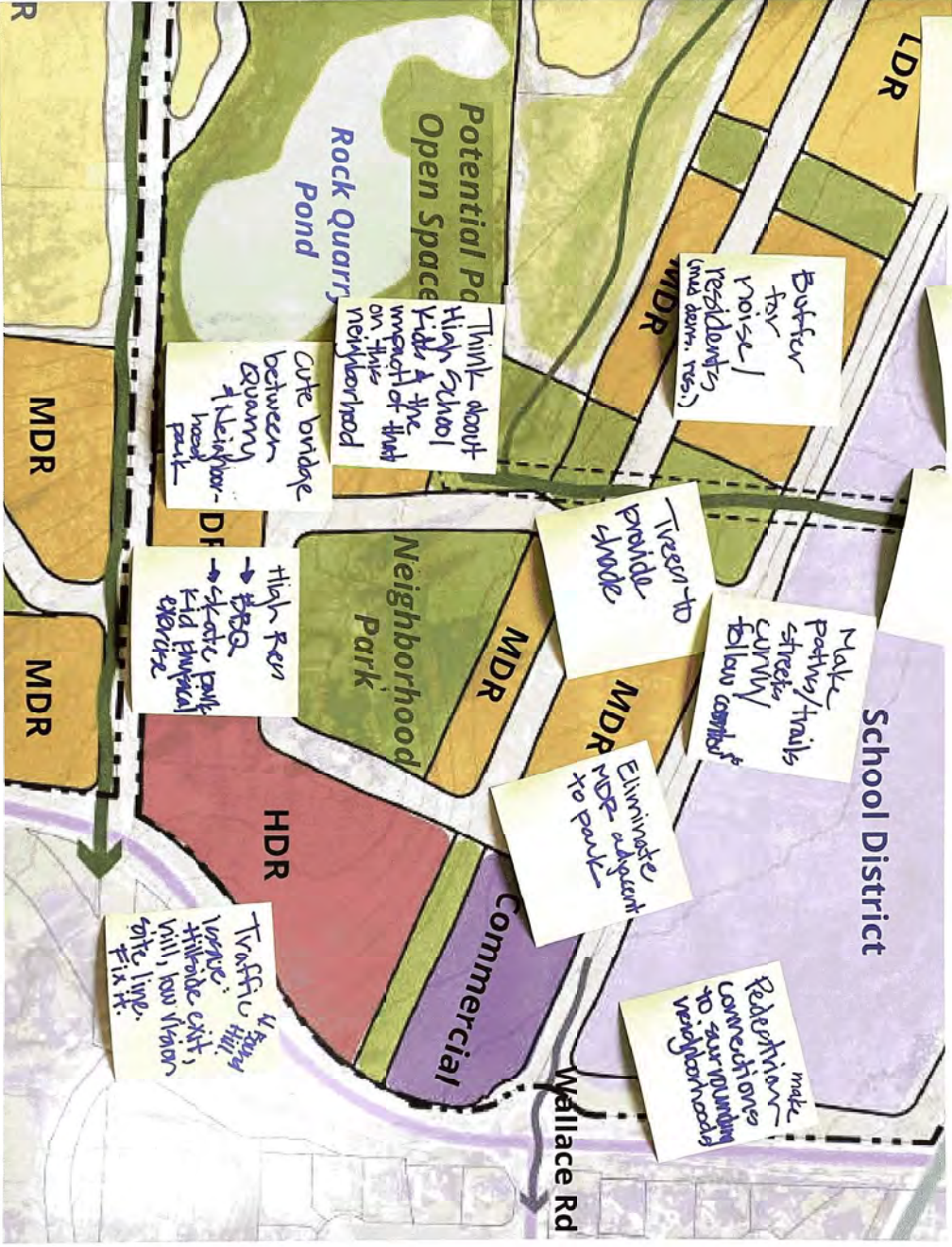

Community gathering area

Model shelter / play area

Like Jay Pearson

Buffer for residents (and down. res.)

Trees to provide shade

Make paths/trails streets curvy / follow contours

Eliminate HDR adjacent to park

Resistances make connections to surrounding neighborhoods

Think about High School kids & the impact of that on this neighborhood

Cute bridge between Quarry & Neighborhood park

High Res → BQ → skate park → kid friendly exercise

Traffic on Hill. Upgrade hillside exit, hill, low station on the line.



MEMORANDUM

City of McMinnville – Fox Ridge Road Area Plan



Date: December 1, 2022
To: Tom Schauer, City of McMinnville
From: Thuy Cao, HHPR
Subject: **City of McMinnville Fox Ridge Road Area Plan
PAC Meeting #1 Summary**

Agenda Items:

1. Call to Order / Roll Call
2. Welcome and Introductions
3. Minutes: None
4. Establishing the PAC
 - a. Committee Role and Ground Rules
 - b. Election of Chair and Vice-Chair
5. Information Sharing and Action Items: Project Overview
6. Action Items – Discussion and Direction
 - a. Evaluation criteria – how will success be measured?
 - b. Public engagement: survey & stakeholder interview
 - c. Existing conditions
 - d. Opportunities and constraints
7. Next Steps
 - a. Tour of planning area
 - b. Survey and stakeholder interviews: Dec-Jan
 - c. Community Design Workshop
 - d. Next PAC meeting
8. Citizen Comments
9. Task Force Member Comments
10. Adjournment

Next PAC Meeting: May 10, 2023

Summary:

This was the first Project Advisory Committee (PAC) meeting for the Fox Ridge Road Area Plan. At the meeting, staff and the consultant provided a PowerPoint presentation that reviewed the project purpose, the role of the PAC, and set ground rules including expectations for the PAC. A thorough overview of the project area reviewed the boundary of the Fox Ridge Road study area, the area planning process, and the MGMUP Framework Plan and its applicable requirements. Discussion was then held to develop the evaluation criteria for the area plan, examine public engagement strategies, and existing conditions including applicable plans and policies; natural features and hazards; and opportunities and constraints. This information and discussion provided the PAC with necessary context to the study area and clarified questions on the project boundary, methods of evaluation, intent of the area plan, and the role of the PAC.

Next Steps:

Following PAC Meeting #1, the HHPR team will:

- Schedule a tour of the Fox Ridge Road planning area with the PAC.
- Publish the online survey based on suggested topics from the PAC and perform stakeholder interviews throughout the months of December and January.
- Work with SERA to develop Opportunities and Constraints diagram prior to Community Design Workshop #1 where we will review housing typologies and land use concepts with the community.
- Report back findings and results from all public engagement at the next PAC meeting.

MEMORANDUM

City of McMinnville – Fox Ridge Road Area Plan



Date: May 10, 2023
To: Tom Schauer, City of McMinnville
From: Thuy Cao, HHPR
Subject: **City of McMinnville Fox Ridge Road Area Plan
PAC Meeting #2 Summary**

Agenda Items:

1. Call to Order / Roll Call
2. Welcome and Introductions
3. Minutes (forthcoming)
4. Selection of Chair and Vice-Chair
5. Information Sharing and Action Items:
 - a. Project Update
 - b. Review of Draft Concepts and Background Information
6. Citizen Comments
7. Task Force Member Comments
8. Adjournment

Next PAC Meeting: June 28, 2023

Summary:

The purpose of the meeting was as follows:

- To provide a project status update to the Project Advisory Committee (PAC),
- To present a summary of the work completed to date, key findings, and the results of public engagement activities.
- To review the three preliminary draft concepts that were prepared based on the work to date, and to obtain input and guidance from the PAC regarding aspects of this work to be developed into a preferred draft concept.

At the last meeting held on December 1, 2022, the Project Advisory Committee was presented with the project summary and schedule and asked to discuss key questions such as the criteria for measuring project success and development scenarios, identifying key stakeholders within the study area, and potential topics for questions to gather feedback for an online survey and stakeholder interviews. Since then, the online survey was conducted, and Community Design Workshop #1 was held on March 21, 2023 to reviewed the opportunities and constraints of the Fox Ridge Road Area and asked community members to provide input on land uses and the development of land use concepts appropriate for the study area. At PAC Meeting #2, Sara Tucholsky was selected as Chair for the Fox Ridge Road Project Advisory Committee, with Sid Friedman selected as the Vice-Chair to the committee. Following this selection, a summary of the work completed to date, key findings , and the results of all public engagement activities were shared with the PAC. Based on these findings and results, three land use concepts were created and presented to the PAC for discussion.



A summary of the key themes from this meeting based on the community design workshop findings and land use concept evaluations are provided below:

Key Themes:

- **Element 1: Neighborhood Park.** The PAC generally agreed that Concept 1 provided the greatest potential for the neighborhood park, centrally located within the Neighborhood Activity Center and allowing for a mix of passive and active recreational uses due to the flat, large, open space area. This open space would allow for sports courts and larger gathering spaces for the community. The Neighborhood Park would not require a parking lot and street parking would be provided within the adjacent higher density uses surrounding the neighborhood park location. This element sparked discussion of the Community Park at the west end, with some committee members sharing their concern for increased traffic due to the size and typical capacity of a Community Park.
- **Element 2: Location of Commercial/Mixed-Use.** Several committee members shared their concerns about the proposed commercial locations regarding access, safety, and traffic. The PAC ultimately agreed that the commercial location near the Wallace Road extension made the most sense when considering traffic and the proximity to the future high school site so that students may have safe access to commercial development. Alternative points and routes for access would need to be considered due to the existing limitations along Hill Road.
- **Element 3: Residential Development and High School Site.** Several committee members shared their concerns for the lack of housing units within the city, expressing their desire to maximize housing units within the concept plan. It was pointed out that the market analysis did indicate that there is market potential above the minimum requirements of acreage for multi-family residential within the study area. A majority of the PAC agreed that medium-density and high-density residential units should be maximized to provide diverse and affordable housing to the area.
- **Element 4: Rock Quarry Pond.** The Rock Quarry Pond had been identified as a key community feature to be preserved. Discussion around the use of the Rock Quarry Pond revolved around the impact of current private ownership and existing hazards surrounding the area. There was interest in preserving the quarry pond as a park that could potentially provide future access to residents, however, the Community Park designation in Concept 3 was not favorable due to the intensity of uses associated with community parks per the Parks Master Plan. A Special Use Park designation was suggested as a possible use to both preserve the quarry pond and provide some limited amenities or access to the natural area.
- **Element 5: Connection at Eastern Edge.** The eastern edge is key to the area plan as it contains the location of the Neighborhood Activity Center and one of the main thoroughfares of Hill Road. The PAC shared significant concerns regarding the speed of traffic and safety of Hill Road, and wanted to ensure that any connections along the eastern edge considered both accessibility and safety of Fox Ridge Road. The PAC expressed interest in the suggested pedestrian greenway that provided a shared use path protected from the street along Fox Ridge Road from Hill Road. North/south connections were discussed as pedestrian trails rather than auto-oriented street connections.
- **Element 6: West End of Fox Ridge Road.** The Community Park identified in Concept 1 was heavily discussed due to repeated concerns about traffic on Fox Ridge Road and impact to adjacent communities. The committee expressed their desire to maintain the natural area located along the northern ridge to preserve identified scenic views, while also agreeing that sports fields may not be appropriate at the west end park. The PAC reached a consensus that a smaller park feature with

benches, canopies and other passive uses would be suitable for the west end. The Community Park was suggested to be shifted towards the east end, however, no location was ultimately decided.

- **Element 7: Southern Ridge and Cemetery.** The Masonic Cemetery was another key community feature identified in the Opportunities and Constraints diagram. Because of its sensitivity, the PAC discussed the use of a buffer between the cemetery and any abutting uses. Specifically, committee members agreed that low-density housing should not be located adjacent to the cemetery.

At the conclusion of the meeting, it was noted that Concept 1 was favored for the provided housing typologies, commercial location, and neighborhood park allocation, with Concept 2 being preferred for the smaller west end park and natural open space designations. The PAC considered the relationship between land uses within the concept plan layouts, urban design components, and a mix of housing densities. The feedback provided by the PAC will be captured within one draft preferred plan that will be presented at the upcoming Community Design Workshop #2 and the following PAC Meeting #3.

Next Steps:

Following PAC Meeting #2, the HHPR team will:

- Work with SERA to create a draft preferred land use concept that reflects the feedback provided from the PAC at the meeting.
- Begin considering draft goals and policies for the Fox Ridge Road Area Plan.
- Prepare for Community Design Workshop #2 to discuss specific neighborhood park uses and opportunities for trails and connections.

MEMORANDUM

City of McMinnville – Fox Ridge Road Area Plan



Date: July 14, 2023
To: Tom Schauer, City of McMinnville
From: Thuy Cao, HHPR
Subject: **City of McMinnville Fox Ridge Road Area Plan
PAC Meeting #3 Summary**

Agenda Items:

1. Call to Order / Roll Call
2. Welcome and Introductions
3. Information Sharing and Action Items, *Exhibit 1:*
 - a. Project Status Update
 - b. Draft Preferred Concept
 - ~~c. Goals and Policies Discussion~~
 - ~~d. Next Steps~~
4. Citizen Comments
5. Task Force Member Comments
6. Adjournment

Next PAC Meeting: August 2, 2023

Purpose:

The purposes of the meeting were as follows:

- To provide a project status update to the Project Advisory Committee (PAC),
- To summarize the work completed to date, key findings, and the results of the most recent public engagement activities.
- To review the draft preferred land use concept developed following guidance from the PAC provided at PAC Meeting #2 and public input received through Community Design Workshop #2.
- To obtain input and guidance regarding draft goals, policies, and implementation measures for the area plan.

At the meeting, staff and the consultant provided a PowerPoint presentation that reviewed a summary of the items above and lead into a discussion regarding the preferred draft land use concept. Due to time restrictions and prolonged discussion regarding the preferred draft land use concept, feedback on potential draft goals and policies for the draft area plan document was not received during the meeting. A summary of the meeting is provided that includes key themes and comments from the Project Advisory Committee that will be taken into consideration when developing the draft goals and policies. An updated draft of the preferred land use concept and the draft goals and policies will be presented at the next PAC meeting on August 2, 2023, for additional comments and final recommendations.

(Graphics presented at reduced scale in this report and attachments were presented with full-sized graphics in the PowerPoint presentation, and large-format hard copies of graphics are available).



Key Themes:

- **Traffic impact from park location on west end of Fox Ridge Road.** When looking at the proposed park location on the west end, committee members shared their concerns for increased traffic impacts along Fox Ridge Road. The PAC agreed that a large community park use would not be appropriate due to the existing traffic concerns along both Hill Road and Fox Ridge Road. However, a smaller scale park feature was expressed to complement the area well.
- **Rock quarry pond discussion – Special Use Park.** Committee members further discussed changes to the draft preferred land use concept that included graphic updates to better reflect the vision for the area plan. Minor changes, such as the depiction of the rock quarry pond needing to be updated to the correct shape, were addressed. Several committee members raised concerns regarding the steep slopes and general terrain surrounding the rock quarry pond. However, many committee members expressed that the rock quarry pond should be designated as a special use park, rather than a community park, as the area is not appropriate for typical recreational uses of a community park but may serve the area better as a natural feature with trail access.
- **Clarification of all green area in Fox Ridge Road and green patches shown in NAC.** Other concept map updates requested by the committee included the distinction between open green spaces, neighborhood park space, and special use park space around the rock quarry pond or elsewhere. The shades of green used to depict these green spaces were noted to be too similar and therefore difficult to distinguish. Specifically, the committee discussed the green patches throughout the neighborhood activity center that were not directly part of the neighborhood park. Those identified green patches were intended to be open green space/buffers between residential buildings and should be separately identified on the draft preferred land use concept for clarification of use.
- **Trails, connectivity, and shorter loops.** The committee reviewed the proposed trails and connectivity of the draft preferred land use concept plan and shared additional feedback concerning both north and south side connections of the Fox Ridge Road area. The north expansion of the McMinnville reservoirs was brought to the committee’s attention, which may impact access through the north side of the area. On the south side of the area, trail access through the low-density residential areas and masonic cemetery were discussed as possible options. Concerns regarding trails being located on the steep topography of the Fox Ridge Road area led to discussion of providing short trail loops as options for accessibility. Alternative street access points for vehicular traffic were also discussed to help alleviate traffic along Fox Ridge Road and provide additional means of connection with the surrounding neighborhoods.
- **Housing densities and the NAC.** There was some discussion about the low-density residential (LDR) designations within a majority of the Fox Ridge Road area, with some committee members sharing their preference for the possibility of a community park designation on some of those areas rather than LDR. However, due to traffic impacts, the committee agreed that a special use park would be favored to a community park use. Within the neighborhood activity center, committee members drew attention to an area previously designated as high-density residential (HDR) that had been changed to medium-density residential (MDR) in the draft preferred land use concept. The committee agreed that due to the location of that specific area on the intersection of Hill Road and Fox Ridge Road, it should return to the HDR designation and be utilized for high-density residential under the plan. An additional update to the draft concept plan is to emphasize property lines of existing parcels to make it clear and legible for existing property owners.

Next Steps:

Following PAC Meeting #3, the HHPR team will:

- Work with SERA to update the draft preferred land use concept and reflect the feedback provided at the meeting.
- Create draft goals, policies and implementation measures based on comments and concerns from both community design workshops and all three Project Advisory Committee meetings for review at the next meeting (to be held August 2nd). These draft goals, policies and implementations will be informed by all community feedback received and will be the topic of discussion during the next Project Advisory Committee meeting (PAC Meeting #4).
- After PAC Meeting #4 the draft goals, policies, and implementation measures based on comments and feedback from the Project Advisory Committee will be refined before being presented at both Planning Commission and City Council work sessions.

MEMORANDUM

City of McMinnville – Fox Ridge Road Area Plan



Date: August 30, 2023
To: Tom Schauer, City of McMinnville
From: Thuy Cao, HHPR
Subject: **City of McMinnville Fox Ridge Road Area Plan
PAC Meeting #4 Summary**

Agenda Items:

1. Call to Order / Roll Call
2. Welcome and Introductions
3. Information Sharing and Action Items:
 - a. Project Status Update
 - b. Refinement of Draft Preferred Concept
 - c. Goals and Policies Discussion
 - d. Next Steps
4. Citizen Comments
5. Task Force Member Comments
6. Adjournment

Next PAC Meeting: September 19, 2023

Purpose:

The purposes of the meeting were as follows:

- To provide a project status update to the Project Advisory Committee (PAC),
- To review the regulatory requirements and planning framework for the area plan.
- To discuss the draft preferred concept highlights and deficiencies.
- To obtain input and guidance regarding draft goals and policies for the area plan.

At the meeting, staff and the consultant provided a PowerPoint presentation that reviewed a summary of the items above and led into a discussion regarding the preferred draft land use concept. In order to clarify the regulatory and planning frameworks of the Fox Ridge Road Area Plan, the regulatory standards and planning goals were carefully reviewed with the PAC, including the MGMUP, MGMUP Framework Plan, McMinnville Comprehensive Plan, and the Parks Master Plan. Using these set requirements, the draft preferred concept was evaluated against all applicable standards and a list of plan highlights and deficiencies was provided to the PAC for review. After discussion on amendments to the preferred concept plan, an open discussion was held regarding aspirational goals and policies the PAC felt the area plan should successfully accomplish. An updated draft of the preferred land use concept and the draft goals and policies will be presented at the next PAC meeting on September 19, 2023, for additional comments and discussion.

(Graphics presented at reduced scale in this report and attachments were presented with full-sized graphics in the PowerPoint presentation, and large-format hard copies of graphics are available).



Key Themes:

- **Community Park designation.** Based on the preferred land use concept map analysis, one of the plan deficiencies identified was the lack of a Community Park designation. The MGMUP Framework Plan calls out a need for a natural resource community park within the study area. After discussion regarding an appropriate location for the park, the PAC agreed that the large open space area located at the west end of the study area would be suitable for a Community Park. This area was selected due to its potential for protecting existing significant tree groves, large acreage to accommodate both passive and active recreational opportunities, and having a potential park feature already identified within the concept plan within that area. The location was also optimal as it connected to the northern ridge that the PAC has identified for natural resource protection and could be connected via primary greenway and secondary trail connections.
- **Neighborhood Park designation.** At the time of analysis, the draft preferred concept identified a Neighborhood Park central to the Neighborhood Activity Center (NAC). However, after analysis, the Neighborhood Park did not meet the maximum distance requirement of being no more than ½-mile away from all residences within the study area. Because of this requirement, the PAC discussed new potential locations for the park that could meet the minimum size and maximum distance requirements. Per staff suggestion, the natural area located north of Fox Ridge Road at the end of Dawson Lane, and the large open area south of Fox Ridge Road abutting the Masonic Cemetery were prime locations for potential neighborhood parks as they were centrally located and could meet all regulatory requirements. The PAC ultimately decided to designate both locations as two separate neighborhood parks within the study area that were accessible on either side of Fox Ridge Road.
- **Open Space/Natural Areas calculations.** The draft preferred land use concept did not include calculations for the areas designated as “natural area,” and the PAC requested that information to be provided within the concept map for reference.
- **Goals and Policies discussion.** The following are comments provided from the PAC regarding goals and policies for the Fox Ridge Road Area Plan:
 - Protect the Rock Quarry Pond.
 - Provide a variety of housing types for current and future residents.
 - High-Density Residential to exceed minimum acreage requirement and to be located at the east end of the study area.
 - Protect existing significant tree groves.
 - Preserve scenic view sheds along the northern ridge of the Fox Ridge Road study area.

Next Steps:

Following PAC Meeting #4, the HHPR team will:

- Work with SERA to update the draft preferred land use concept and reflect the feedback provided at the meeting.
- Create draft goals and policies based on PAC feedback and comments from previous online survey responses and community design workshops.

MEMORANDUM

City of McMinnville – Fox Ridge Road Area Plan



Date: September 19, 2023
To: Tom Schauer, City of McMinnville
From: Thuy Cao, HHPR
Subject: **City of McMinnville Fox Ridge Road Area Plan
PAC Meeting #5 Summary**

Agenda Items:

1. Call to Order / Roll Call
2. Welcome and Introductions
3. Information Sharing and Action Items
 - a. Project Status Update
 - b. Draft Concept Analysis and Refinement
 - c. Goals and Policies Discussion
 - d. Next Steps
4. Citizen Comments
5. Task Force Member Comments
6. Adjournment

Next PAC Meeting: November 29, 2023

Summary:

The purpose of the meeting was as follows:

- To provide a project status update to the Project Advisory Committee (PAC),
- To review the most recent land use concept map analysis.
- To obtain input on the draft goals and policies for the area plan.

At the last meeting held on August 30, the Project Advisory Committee was presented with deficiencies in the land use concept plan and asked to provide input on how to address those planning requirements that were not currently being met by the plan. Based on that feedback, SERA revised the plan and provided an updated concept plan for review at PAC Meeting #5. At this meeting, staff and the consultant reviewed an analysis of the updated preferred land use concept and the newly proposed locations for neighborhood parks within the area plan. The Project Advisory Committee was then asked to provide input based on the analysis for further refinement of the concept plan. After reaching consensus on those refinements, the draft goals and policies were then reviewed with comments being provided from the committee for revisions or additions to the goals and policies of the area plan. A summary of the meeting is provided that includes key themes and comments from the Project Advisory Committee that will be taken into consideration when developing the draft Area Plan.



Key Themes:

- **Neighborhood Park locations.** As a result of discussion during PAC Meeting #4, there were ultimately two neighborhood park locations identified to satisfy the park distance and minimum size requirements for the area. However, when reviewing the analysis for both locations in context of existing slopes, significant tree groves, and natural hazard overlays, the PAC was asked to reconsider the siting of two neighborhood parks. The PAC was asked to consider the incorporation of Neighborhood Park Location #1 (north of Fox Ridge Road at the end of Dawson Lane) as part of the open space network and removing the neighborhood park designation due to its limited use. Rather, Neighborhood Park Location #2 (south of Fox Ridge Road, above the Masonic Cemetery) would be expanded to the east to increase the designated size, allowing for a flatter area suitable for a mix of both active and passive recreation areas. The PAC agreed to these suggestions, acknowledging that Neighborhood Park Location #2 would exceed the minimum size criteria, meet the maximum distance of ½-mile from residences as it is centrally located within the study area, helped preserve identified significant tree groves, and would have flat areas for typical uses associated with neighborhood parks. The PAC also confirmed the establishment of a natural buffer along the area abutting the Masonic Cemetery.
- **Goals and Policies discussion.** Several comments were provided from the PAC regarding amendments to the Area Plan goals and policies. Specifically, suggestions for additional policies included clarifying language on aesthetics and design, lighting to accommodate dark sky practices, safety design features, or placement of specific amenities. Many of these suggestions are addressed through the City's development standards, Great Neighborhood Principles, and language within the draft goals and policies that will be considered at the time of new development prior to any new construction. Additional language has been added to the goals and policies to support the concerns and comments of the PAC where feasible.
- **Preferred Land Use Concept updates.** Concept map updates will need to include the updated Neighborhood Park location and natural buffer from the Masonic Cemetery, along with visual changes to make the map more legible such as differentiating the color of the primary and secondary trails.

Next Steps:

Following PAC Meeting #5, the HHPR team will:

- Update the draft preferred land use concept and reflect the feedback provided at the meeting.
- Amend the draft goals and policies based on comments and concerns from the PAC.
- Present the updated preferred land use concept map, goals and policies, and key findings at the joint Planning Commission and City Council work session scheduled October 10, 2023.

MEMORANDUM

City of McMinnville – Fox Ridge Road Area Plan



Date: November 29, 2023
To: Tom Schauer, City of McMinnville
From: Thuy Cao, HHPR
Subject: **City of McMinnville Fox Ridge Road Area Plan
PAC Meeting #6 Summary**

Agenda Items:

1. Call to Order / Roll Call
2. Welcome and Introductions
3. Information Sharing and Action Items:
 - a. Update on Joint Planning Commission/City Council Work Session
 - b. Recommendations on Draft Fox Ridge Road Area Plan.
4. Citizen Comments
5. Task Force Member Comments
6. Adjournment

Purpose:

The purposes of the meeting were as follows:

- To provide an update on the joint Planning Commission/City Council work session and associated updates to the draft Area Plan Map and Goals and Policies.
- To obtain a recommendation from the PAC on the draft area plan that will go to the Planning Commission in the legislative public hearing process.

At the meeting, staff and the consultant provided a PowerPoint presentation that reviewed a summary of the items above and lead into discussion regarding the draft Area Plan Map, goals and policies, and area plan document. A summary of the meeting is provided that includes key themes and comments from the Project Advisory Committee that will be taken into consideration when refining the draft Fox Ridge Road Area Plan document and Area Plan Map. Updated drafts will be presented to the Planning Commission at a public hearing scheduled for January 4, 2024.

Key Themes:

- **Area Plan Map.** Based on comments provided at the joint Planning Commission/City Council work session, the Project Advisory Committee agreed with the following changes to the Plan Map:
 - Increase the area designated for commercial/mixed-use within the NAC.
 - Rearrange the high- and medium-density residential configuration so that all high-density residential land use is located north of Fox Ridge Road.
 - Clearly delineate a multi-use path (Greenway along Fox Ridge Road).



- Better illustrate the NAC area on the Plan Map to clearly show the NAC boundary with labeled focus and support areas.
- **Goals and Policies.** The Project Advisory Committee considered comments provided from the joint Planning Commission/City Council work session and provided guidance on the following:
 - Include specific goals and policies for natural resource protection and conservation, especially relative to protected tree groves (including tree grove west of Dawson Lane along Fox Ridge Road). This will be accomplished during the Natural Resources Planning that is planned to occur in the near future for inventory and protection/mitigation.
 - Include specific goal and policy language regarding natural hazards and the planned reduction of density in areas with multiple natural hazards.
 - Ensure that the western park area (previously labeled as a Community Park) is developable and annexation timing/phasing issues will not prevent the realization of the natural resource park by removing the community park designation and identifying the whole area as a Natural Resource Park with trails for connections and scenic viewpoints.
 - Create a policy that planned multi-use paths should be a minimum of 10 – 12 feet wide for utility purposes.
 - Include language as a goal to protect dark night skies by preventing light pollution from new future developments.
- **Plan Narrative.** Additional narrative was discussed to help clarify specific comments and concerns raised by both the Planning Commission/City Council and the Project Advisory Committee:
 - Provide narrative in the plan equating LDR, MDR and HDR to specific city zoning (i.e., LDR is R1 (9,000 minimum lots) and R2 (7,000 minimum lots), MDR is R3 (6,000 minimum lots) and R4 (5,000 minimum lots) and HDR is R5 (multi-family only).
 - Provide narrative in the plan specifying that the Neighborhood Activity Center overlay is intended to be applied at the Wallace Road roundabout with the intent to encourage mixed-use development (ground floor commercial and upper floor residential) radiating out to high density residential and eventually medium density residential, utilizing language from the Comprehensive Plan and Zoning Ordinance.
 - Provide narrative in the plan specific to the planned Special Use Park/Rock Quarry Pond in terms of utilizing it as a nature resource park that serves the community with trail systems and interpretation for the ecosystem of the area.
 - Provide narrative about the Natural Resource Park as an intentional park to preserve natural resources that serve the community with trails systems, view sheds and protected ecosystems along the ridgeline such as significant tree groves.

Next Steps:

Following the final PAC Meeting #6, the HHPR team will:

- Revise the Draft Fox Ridge Road Area Plan document to submit to DLCD for noticing prior to the Planning Commission hearing.
- Update the preferred land use concept map or “Area Plan Map” to better illustrate the NAC including focus and support areas, as well as primary and secondary trails.
- Prepare for the Planning Commission hearing scheduled for January 4th, 2024.



**MARKET ANALYSIS FOR
HIGH DENSITY RESIDENTIAL AND COMMERCIAL USES
IN THE FOX RIDGE ROAD PLANNING AREA,
MCMINNVILLE, OREGON**

PREPARED FOR
CITY OF MCMINNVILLE,
APRIL 2023

JOHNSON ECONOMICS, LLC

621 SW Alder St, Suite 506
Portland, Oregon 97205



**JOHNSON
ECONOMICS**

TABLE OF CONTENTS

I.	INTRODUCTION	1
II.	EXECUTIVE SUMMARY	1
	RENTAL APARTMENTS	1
	OWNERSHIP HOUSING	2
	COMMERCIAL SPACE	3
	CONCLUSIONS	3
III.	RENTAL HOUSING	5
	MARKET TRENDS	5
	SURVEY OF COMPARABLES	7
	ACHIEVABLE PRICING	12
	ABSORPTION	13
IV.	OWNERSHIP HOUSING	14
	MARKET TRENDS	14
	SURVEY OF COMPARABLES	16
	ACHIEVABLE PRICING	21
	ABSORPTION	23
V.	COMMERCIAL SPACE	24
	MARKET TRENDS	24
	SURVEY OF COMPARABLES	26
	HOUSEHOLD SUPPORT	31
	ABSORPTION	36
	ACHIEVABLE PRICING	37
VI.	CONCLUSIONS	38
	FEASIBLE USES	38
	FEASIBLE BUILDING FORMATS	38
	LOCATION OF USES	40



I. INTRODUCTION

This report presents a market and feasibility analysis for residential and commercial uses in the Neighborhood Activity Center (NAC) envisioned within the Fox Ridge Road planning area in McMinnville, Oregon. The main objectives of the study are to provide market overviews; generate reliable assumptions with respect to achievable pricing and absorption; and outline feasible uses, scale, and development forms within the NAC. The residential analysis is focused on high-density uses, evaluating rental and ownership housing separately.

The market analysis is organized in three main sections: Rental Housing, Ownership Housing, and Commercial Space. For each use, we provide an overview of market trends, conduct a survey of comparable properties, and analyze achievable pricing and absorption within the NAC. Residential absorption estimates draw in part on conclusions from the most recent Housing Needs Analysis completed for the City of McMinnville (ECONorthwest, 2019). Identification of feasible uses, development forms, and scale is provided in the Conclusions.

II. EXECUTIVE SUMMARY

RENTAL APARTMENTS

MARKET TRENDS

Demand for rental housing increased over the last decade, reflecting higher thresholds to homeownership and strong millennial household formation. McMinnville has not seen the same development response to this demand as most other cities, and the city experienced a decline in multifamily development over the last decade. The apartment shortage has resulted in a low vacancy rate, currently 1.2% - well below the 5.0% that typically represents a balanced market. In comparison, vacancy rates in the Salem and Portland metro areas are currently 3.9% and 4.5%, respectively.

Rent levels in McMinnville are relatively low, with monthly averages of \$1,200 per unit and \$1.41 per square foot. This may have deterred some new development over the past decade. However, the low vacancy rates suggest that many properties are priced below market-clearing levels.

SURVEY OF COMPARABLES

JOHNSON ECONOMICS surveyed five apartment projects of relatively recent vintage in McMinnville for this analysis. Together, the properties have only three vacant units, representing a vacancy rate of 0.7%. This is unusually low, indicating capacity for additional supply and rent growth. The average rent level across the properties is \$1,524 per unit and \$1.66 per square foot. Some of the properties exhibit clear indications of underpricing.

ACHIEVABLE PRICING

We estimate that a new mid-market apartment project with surface parking in the NAC can achieve monthly rents in the range of \$1,380-\$1,750 per unit in today's market, depending on unit type and size, with per-square-foot (PSF) rents in the \$1.59-1.98 range. These rates are adequate to support traditional walk-up structures, but likely not adequate for more costly formats like elevator buildings with tuck-under or podium parking. We estimate that rental townhomes can achieve rents around \$2,000 per unit and \$1.59 PSF, plus premiums of \$100-150 for attached garages.

FIGURE 2.1: ACHIEVABLE RENTAL PRICING (1Q23)

Unit Type	Units	Unit Allocation	Average Unit Size	Rent per Unit	Rent per Square Foot
1B/1b Apt	50	30%	700	\$1,384	\$1.98
2B/2b Apt	70	42%	900	\$1,604	\$1.78
3B/2b Apt	30	18%	1,100	\$1,752	\$1.59
3B/2b TH	15	9%	1,300	\$1,957	\$1.51
Total/Avg.	165	100%	912	\$1,596	\$1.75

SOURCE: JOHNSON ECONOMICS



ABSORPTION

In the current low-vacancy market, we estimate that an apartment project in the NAC could achieve absorption of around 200 units in a year. Assuming a less pressured market in future years, we estimate that around 150 units can be absorbed in a year, plus around 15 rental townhomes. With two phases separated by 1-2 years of stabilized phase-one operations, we would assume that a project of twice this scale could be built within the NAC.

OWNERSHIP HOUSING

MARKET TRENDS

For-sale attached homes were harder hit during the 2008-09 recession than detached homes due to buyers in this segment generally being younger and more sensitive to layoffs and tightened credit standards. However, the market for attached homes has since recovered, though construction of new attached homes has been very limited in McMinnville. Thus, attached homes represent a smaller share (6%) of all homes sales in McMinnville currently than 10 years ago (10%).

Both attached and detached homes have been undersupplied in McMinnville over the past 10 years, resulting in significant declines in the market time for listed units. In 2022, the median market time was 10 days, while 60-90 days is generally considered to represent a balanced market. The undersupply has caused rapid price gains, as in all other parts of the region, with the median price of attached homes gaining 11.6% per year on average over the past 10 years. In 2022, the median price of attached homes in McMinnville was \$369,000, or \$264 PSF.

SURVEY OF COMPARABLES

JOHNSON ECONOMICS surveyed five subdivisions in McMinnville for this analysis. Three are townhome projects built out between 2004 and 2009, while two are newer detached-home projects with homes built over the past three years. Adjusting sales prices from the past three years to current values using the county median, the homes range from around \$243,000 to \$710,000, or \$188 to \$322 PSF. The average value is \$412,000 per home and \$243 PSF.

ACHIEVABLE PRICING

Based on the resale prices in the surveyed townhome subdivisions and new-home prices in the detached-home subdivisions (adjusted based on typical townhome discounts), we estimate that townhomes in the NAC in the current market would represent pricing in the range of \$360,000 to \$440,000, or \$243-258 PSF. This is likely adequate to support construction of suburban townhomes with a mid-market profile in the NAC.

FIGURE 2.2: ACHIEVABLE OWNERSHIP PRICING, 1Q23

2-STORY TH. Type	UNIT MIX				PRICING	
	Units (#)	Units (%)	Home Size	Lot Size	Per Home	Per SF
2B/2.5b	10	33%	1,400	2,000	\$361,400	\$258
3B/2.5b	10	33%	1,600	2,500	\$400,400	\$250
3B/2.5b	10	33%	1,800	3,000	\$436,600	\$243
Total	30	100%	1,600	2,500	\$399,467	\$250

SOURCE: JOHNSON ECONOMICS

ABSORPTION

Assuming a normalization of mortgage rates in future years, we estimate that around 15 for-sale townhomes can be absorbed annually in the NAC. This assumes that the supply of new townhomes continues to be limited elsewhere in the city.



COMMERCIAL SPACE

MARKET TRENDS

As in most other places, the shift to online shopping has constrained commercial development in McMinnville in recent years. 2006 was the last year with a substantial amount of new supply, when 81,000 square feet were added to the market. Over the past 10 years, only 34,000 square feet have been completed, according to CoStar. However, 87,000 square feet were absorbed on a net basis over this period, resulting in declining vacancy. The current vacancy rate is 1.8%, which is unusually low. This compares to 2.0% in Salem Metro and 3.5% in Portland Metro. Lease rates have risen in recent years, roughly in pace with general inflation.

SURVEY OF COMPARABLES

JOHNSON ECONOMICS surveyed six commercial properties with a neighborhood orientation for this study: two just south of the NAC at the 2nd Street/Hill Road intersection (built 1990 and 2009), and four from other parts of the Portland-Salem region (built 2008-22). The latter represent some of the most recent commercial developments in peripheral suburban locations in the region. Annual PSF lease rates at the two McMinnville properties are \$18 (modified gross) and \$27.36 (full service). The four regional comparables represent lease rates in the \$23.50-28.00 range (triple net).

ABSORPTION

Current traffic volumes and household counts around the NAC indicate inadequate support for new construction commercial space in the NAC. However, following the completion of 570 housing units in the Fox Ridge planning area, a commercial center in the NAC would be the closest shopping location for an estimated 1,500 households. At that point, we expect a small commercial project with 5,000-10,000 square feet to be feasible in the NAC, primarily with food/beverage and service tenants. Additionally, we expect a daycare center and possibly a gas station with a convenience store to be feasible around the same time.

ACHIEVABLE PRICING

The surveyed comparables and the households sales estimates for the area around the NAC indicate lease rates in the low end of what can support new construction, likely requiring cost-effective designs and features. Based on today's market rates, we would expect lease rates in the \$24-27 range (NNN) to be achievable, with somewhat lower rates for a daycare center.

FIGURE 2.3: POTENTIAL TENANTS AND ACHIEVABLE PRICING (1Q23)*, SUBJECT SITE

#	MAJOR CATEGORY	CATEGORY	SQ.FT.	FAR	ACRES	RATE LOW	RATE HIGH
1	Eating/drinking places	Restaurant	2,800	0.25	0.3	\$25.00	\$27.00
2	Eating/drinking places	Restaurant/coffee	1,500	0.25	0.1	\$25.00	\$27.00
3	Personal care	Hair/nail/spa salon	1,500	0.25	0.1	\$24.00	\$26.00
4	Health/medical services	Physician/chiropractor	1,500	0.35	0.1	\$24.00	\$26.00
5	Professional/financial services	Real estate/insurance	1,000	0.35	0.1	\$24.00	\$26.00
6	Education	Daycare/preschool	4,000	0.30	0.3	\$22.00	\$24.00
Total:			12,300		1.0	\$22.00	\$27.00

* Achievable lease rates are annual NNN rates per square foot.

SOURCE: JOHNSON ECONOMICS

CONCLUSIONS

FEASIBLE USES

This analysis indicates adequate market support for rental apartments, rental townhomes, ownership townhomes, and commercial space in the NAC. With a single-phase, 12-month absorption period, we estimate that 170 housing units are feasible in the NAC. We would expect these to require roughly eight acres of land. A strip mall and daycare center may need another acre of land, while an additional acre might be absorbed by a gas station with convenience store. Together, these uses would bring the total size of the NAC to roughly 10 acres.



FIGURE 2.4: POTENTIAL LAND ABSORPTION

FEASIBLE USES				Res. Density	Com.	Land Need
LAND USE	Scale	Unit	(U/Ac)	FAR	(Acres)	
Rental apartments	150	Units	28			5.4
Rental townhomes	15	Units	14			1.1
Ownership townhomes	15	Units	10			1.5
Retail space	8,300	SF		0.27		0.7
Daycare center	4,000	SF		0.30		0.3
Gas station w/conv. store	5,000	SF		0.15		0.8
Total						8.9 (9.7)

SOURCE: JOHNSON ECONOMICS

We expect there will be potential for a larger residential component, at roughly twice the indicated scale, assuming absorption over a three- to four-year period. This would shorten the time needed to develop adequate support for the commercial component. However, the land need for the NAC would then likely increase to around 17-18 acres.

FEASIBLE BUILDING FORMATS

Based on the anticipated market support and pricing, rental apartments in the NAC are likely to be of a three-story walk-up format with surface parking. The rental townhomes will likely be two-story structures, either with or without attached garages. The ownership townhomes are most likely to be two-story structures with attached garages.

Commercial space for food/beverage and service tenants is most likely to have a standard single-story strip mall format, while a daycare center is most likely to be a single-story building with a gable roof.

LOCATION OF USES

Commercial activity in the NAC will depend on good exposure to auto traffic, and will therefore need a location near one of the major Hill Road intersections, either at Wallace Road or Fox Ridge Road. Assuming future development of the high school site, the Wallace Road intersection will likely provide the strongest exposure, positioning the commercial component to capture demand from residents east of Hill Road in addition to Fox Ridge residents. This will require a site and road layout that provides easy access between Fox Ridge Road and the commercial center.

Both rental apartments and townhomes function well adjacent to commercial uses from a market standpoint. However, we therefore recommend rental apartments closest to the commercial section, as rental housing tends to benefit more from this proximity.



III. RENTAL HOUSING

MARKET TRENDS

SUPPLY AND DEMAND

Demand for rental housing increased notably during the last decade, following the foreclosure crisis and recession in the late 2000s. Stricter credit conditions resulted in fewer households qualifying for mortgages, while rapidly rising college tuition and rents made it more difficult – especially for young households – to save up for the higher downpayment requirements. Thus, segments of the previous homeowner market were now relegated to the rental market. Early in the decade, there was excess supply of ownership housing left over from the foreclosures. Many of these were bought by investors and turned into rentals. As the ownership market recovered and these homes appreciated rapidly, many investors sold the homes – predominantly to owner-occupants. This reduced the supply of single-family rentals, forcing many renters into apartments. Thus, most markets saw strong gains in apartment demand over the decade, which in many places was met by a record construction pace.

McMinnville has not seen the same increase in apartment construction as most other parts of the region. Multifamily building permits for buildings with five or more units averaged 40 units annually over the past decade, compared to 60 units annually during the 2000s (likely including some condominium flats). According to CoStar, which tracks most rental apartment properties with online listings, the supply of new apartments in McMinnville over the past decade was roughly on par with the supply in the prior decade. The new supply was generally absorbed quickly. Net market absorption was as high as 140 units annually in 2017 and 2020, when large new projects were completed. The market absorption has been constrained by a lack of new supply over the past two years, as it was in the first half of the last decade. Note that the CoStar data does not include all recent projects in McMinnville. The Housing Needs Analysis recently completed for the City of McMinnville estimates a need for 75 new multifamily units annually over the coming years – most of which will be rental apartments.

FIGURE 3.1: APARTMENT DELIVERIES AND NET ABSORPTION (2000-22)

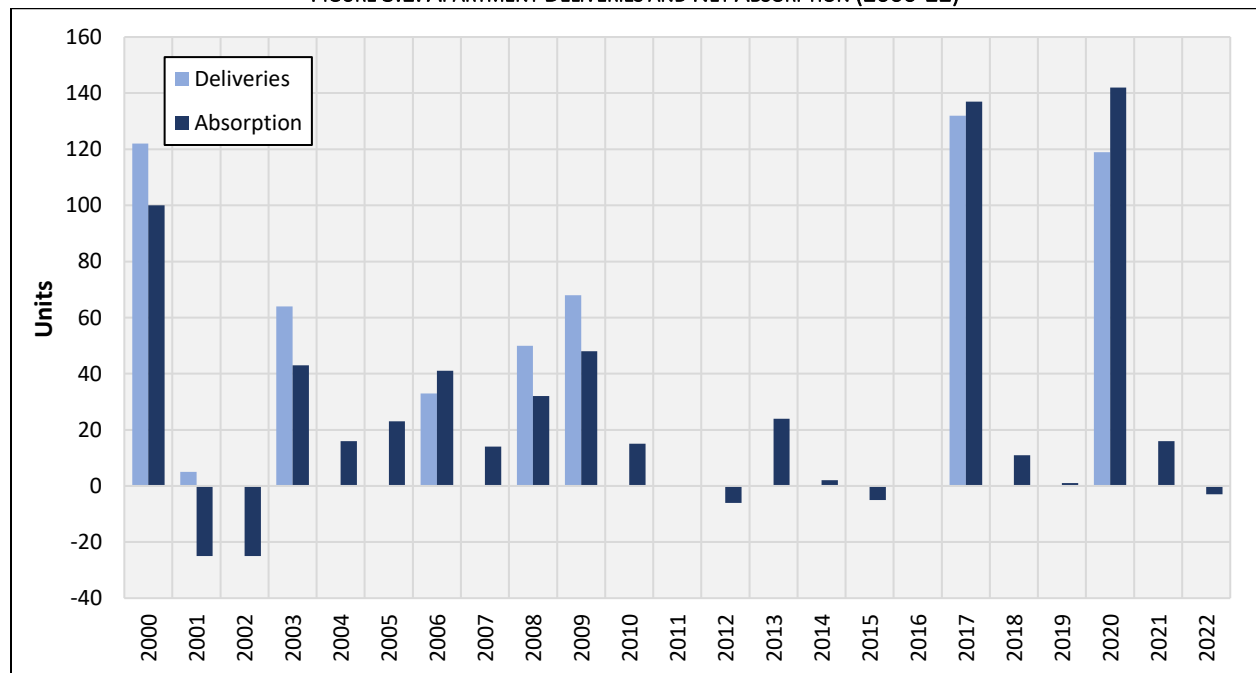

SOURCE: CoStar, JOHNSON ECONOMICS



VACANCY AND RENT GROWTH

Reflecting the limited new supply, apartment properties in McMinnville have seen a decline in vacancy rates over the past 10 years, with a current rate of 1.2%, according to CoStar. A 5.0% rate is generally considered to represent a balanced market, where supply matches demand, and rent growth is kept in line with general income growth. McMinnville has not been at this level since late 2012, when its vacancy rate was on par with that of the Portland and Salem metro areas. Over the following 10 years, the city followed the Salem market for a while, but has diverged from the Salem trend over the past three years. The current low vacancy rate indicates considerable pent-up demand.

One of the factors that has likely sustained strong occupancy in McMinnville is its relatively affordable rent levels. According to CoStar, its average rent level for market-rate units is currently \$1,200 per unit and \$1.41 per square foot. This is well below the average in the Salem and Portland markets. Moreover, properties in McMinnville have not raised their rents as quickly as most properties in these markets, despite stronger occupancy. Over the past five years, the market-wide rent growth has averaged 4.5% per year. The current low vacancy rate suggests that the market is somewhat underpriced currently. The relatively low rents may have deterred new development over the past decade.

FIGURE 3.2: STABILIZED VACANCY AND AVERAGE RENT PER SQUARE FOOT, GEOGRAPHIC COMPARISON

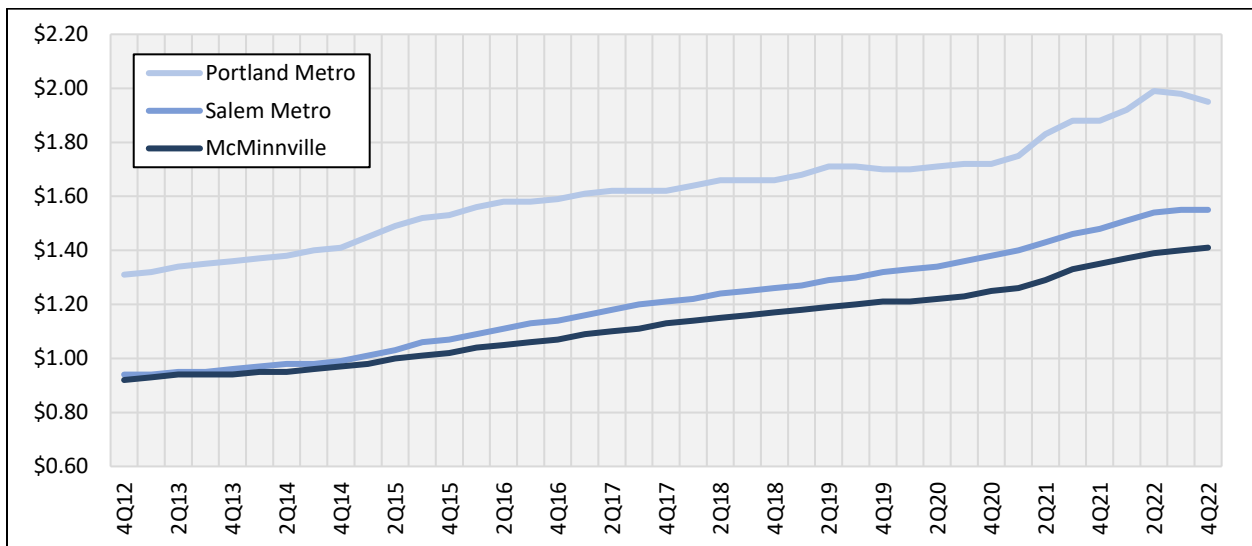
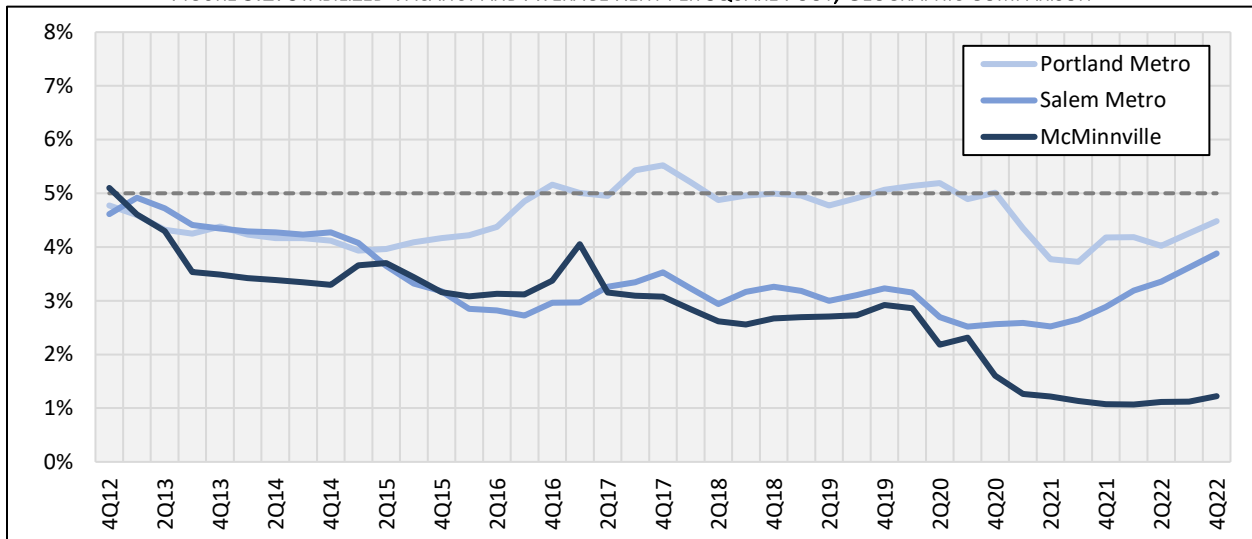

SOURCE: CoStar, JOHNSON ECONOMICS



SURVEY OF COMPARABLES

COMPARABLES

JOHNSON ECONOMICS surveyed five apartment projects of relatively recent vintage in McMinnville for this analysis. Three of these opened over the past three years, while one opened in 2016 and one in 2009. The projects represent a typical suburban, walk-up format, with multiple two- or three-story buildings. None of the projects include ground-floor commercial space, which is not represented at apartment projects in suburban parts of McMinnville.

The following map shows the locations of the surveyed properties. Detailed profiles of the projects are included over the next pages, followed by a rent and vacancy summary.

FIGURE 3.3: MAP OF SURVEYED APARTMENT PROPERTIES

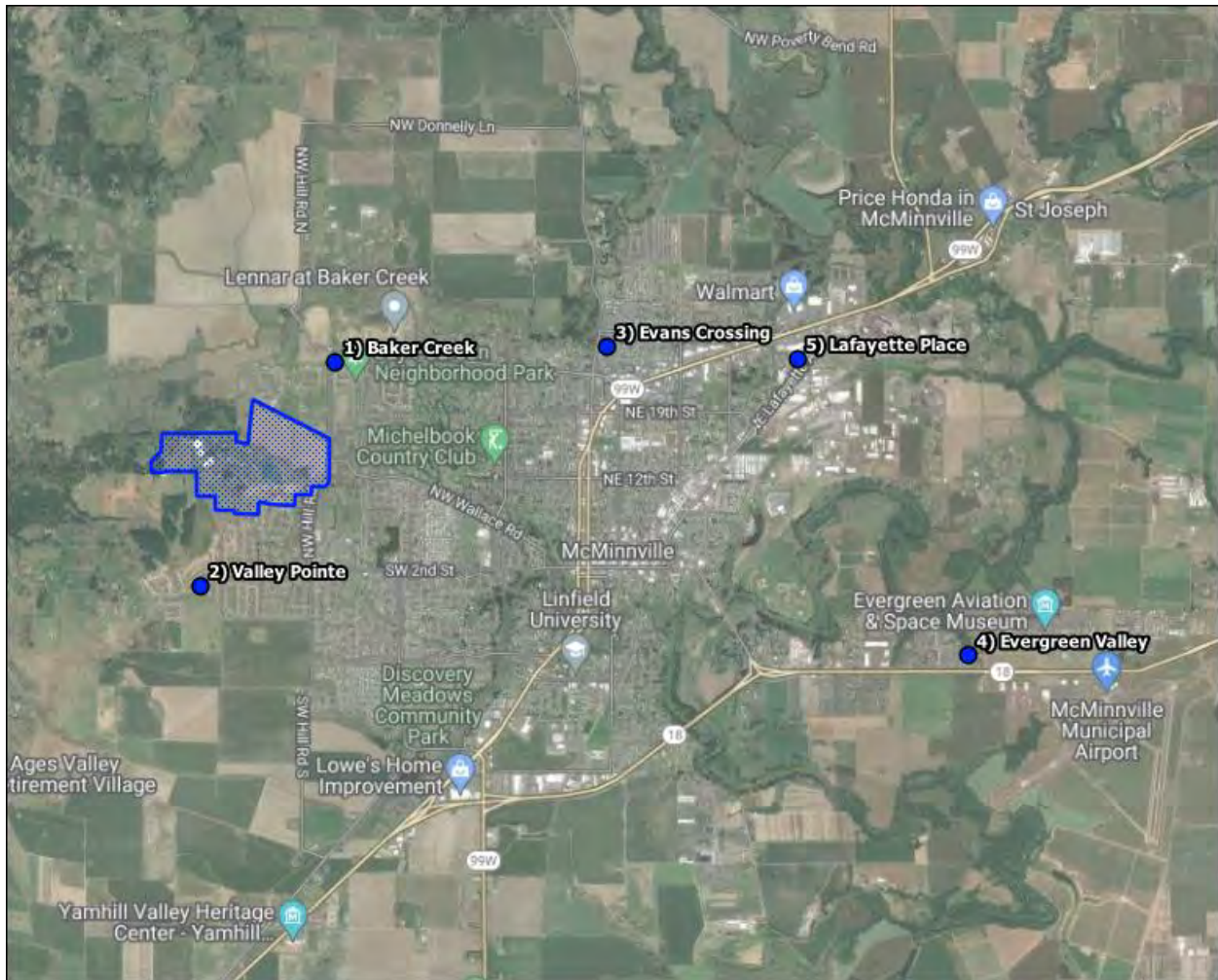

SOURCE: JOHNSON ECONOMICS



FIGURE 3.4: PROFILES OF SURVEYED APARTMENT PROPERTIES

1 - BAKER CREEK APARTMENTS

2005 NW 23rd St, McMinnville, OR



YEAR BUILT: 2021
TOTAL UNITS: 70
PARKING SPACES/UNIT: 1.64
OCCUPANCY: 98.6%
AVERAGE RENT/SF: \$1.47

Project Amenities

Clubhouse
 Playground
 Lawn/park
 On-site management

Unit Amenities

Vinyl plank flooring
 Solid surface countertops
 Stainless steel appliances
 9-foot ceilings, washer/dryer
 Balcony

	UNIT CHARACTERISTICS			OCCUPANCY		RENTS			
	Units (#)	Units (%)	Avg. Size	Vac. (#)	Occ. (%)	Low	High	Average	Avg. PSF
1B/1b	11	16%	750	0	100%	\$1,200	\$1,200	\$1,200	\$1.60
2B/2b	54	77%	952	1	98%	\$1,400	\$1,400	\$1,400	\$1.47
3B/2b	5	7%	1,204	0	100%	\$1,575	\$1,575	\$1,575	\$1.31
Tot./Avg:	70	100%	938	1	99%	\$1,200	\$1,575	\$1,381	\$1.47

2 - VALLEY POINTE

2825 SW 2nd St, McMinnville, OR

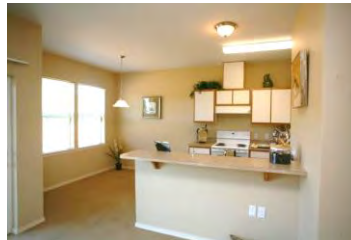

YEAR BUILT: 2009
TOTAL UNITS: 68
PARKING SPACES/UNIT: 1.69
OCCUPANCY: 100.0%
AVERAGE RENT/SF: \$1.69

Project Amenities

Park
 Playground
 (Pets not allowed)

Unit Amenities (Renovated)

Laminate counters, white appliances
 Carpet and vinyl flooring
 Washer/dryer hookups
 9' and vaulted ceilings
 Patio/balcony

	UNIT CHARACTERISTICS			OCCUPANCY		RENTS			
	Units (#)	Units (%)	Avg. Size	Vac. (#)	Occ. (%)	Low	High	Average	Avg. PSF
2B/1b	34	50%	832	0	100%	\$1,400	\$1,400	\$1,400	\$1.68
2B/2b	34	50%	918	0	100%	\$1,550	\$1,550	\$1,550	\$1.69
Tot./Avg:	68	100%	875	0	100%	\$1,400	\$1,550	\$1,479	\$1.69



3 - EVANS CROSSING APARTMENTS

2501 NE Evans St, McMinnville, OR



YEAR BUILT: 2020
TOTAL UNITS: 119
PARKING SPACES/UNIT: 1.61
OCCUPANCY: 99.2%
AVERAGE RENT/SF: \$1.65



Project Amenities

Laundry room
 Dog park
 On-site management



Unit Amenities

Vinyl plank, carpet flooring
 Laminate countertops
 White appliances
 9-foot ceilings
 Balcony

	UNIT CHARACTERISTICS			OCCUPANCY		RENTS			
	Units (#)	Units (%)	Avg. Size	Vac. (#)	Occ. (%)	Low	High	Average	Avg. PSF
1B/1b	18	15%	704	0	100%	\$1,350	\$1,350	\$1,350	\$1.92
2B/1b	24	20%	940	1	96%	\$1,450	\$1,450	\$1,450	\$1.54
2B/2b	77	65%	965	0	100%	\$1,575	\$1,575	\$1,575	\$1.63
Tot./Avg:	119	100%	920	1	99%	\$1,350	\$1,575	\$1,523	\$1.65

4 - EVERGREEN VALLEY APARTMENTS

725 SE Ford St, McMinnville, OR



YEAR BUILT: 2020
TOTAL UNITS: 66
PARKING SPACES/UNIT: 1.74
OCCUPANCY: 100.0%
AVERAGE RENT/SF: \$1.78



Project Amenities

Playground
 Dog park



Unit Amenities

Granite countertops
 Vinyl and carpet flooring
 Stainless steel appliances
 8-foot ceilings, A/C
 Balcony

	UNIT CHARACTERISTICS			OCCUPANCY		RENTS			
	Units (#)	Units (%)	Avg. Size	Vac. (#)	Occ. (%)	Low	High	Average	Avg. PSF
2B/2b	66	100%	952	0	100%	\$1,695	\$1,695	\$1,695	\$1.78
Tot./Avg:	66	100%	952	0	100%	\$1,695	\$1,695	\$1,695	\$1.78



5 - LAFAYETTE PLACE

2349 NE Lafayette Ave, McMinnville, OR



YEAR BUILT: 2016
TOTAL UNITS: 132
PARKING SPACES/UNIT: 1.57
OCCUPANCY: 99.2%
AVERAGE RENT/SF: \$1.73



Project Amenities
 Community lounge
 Fitness room
 Dedicated surface parking
 (Pets not allowed)



Unit Amenities
 Tile countertops, cherry wood cabinets
 Carpet and vinyl plank flooring
 Black appliances, washer/dryer
 A/C, ceiling fan, 8'/vaulted ceilings
 Balcony/patio w/storage

	UNIT CHARACTERISTICS			OCCUPANCY		RENTS			
	Units (#)	Units (%)	Avg. Size	Vac. (#)	Occ. (%)	Low	High	Average	Avg. PSF
1B/1b	36	27%	725	1	97%	\$1,395	\$1,395	\$1,395	\$1.92
2B/2b	96	73%	952	0	100%	\$1,595	\$1,595	\$1,595	\$1.68
Tot./Avg:	132	100%	890	1	99%	\$1,395	\$1,595	\$1,540	\$1.73

SOURCE: Property managers/agents, property websites, Craigslist, RealPage, CoStar, JOHNSON ECONOMICS

FIGURE 3.5: RENT AND OCCUPANCY SUMMARY, SURVEYED APARTMENT PROPERTIES

Project Name/ Location	Year	Occupancy	UNIT CHARACTERISTICS					RENT CHARACTERISTICS				
			Type	Units	Mix	Sq. Ft.	Vacant	Low Rent	High Rent	Avg. Rent	Avg. Rent Per SF.	
1) Baker Creek Apts. 2005 NW 23rd St, McMinnville, OR	2021	99%	1B/1b	11	16%	750	0	0%	\$1,200	\$1,200	\$1,200	\$1.60
			2B/2b	54	77%	952	1	2%	\$1,400	\$1,400	\$1,400	\$1.47
			3B/2b	5	7%	1204	0	0%	\$1,575	\$1,575	\$1,575	\$1.31
			Tot./Avg:	70	100%	938	1	1%	\$1,200	\$1,575	\$1,381	\$1.47
2) Valley Pointe 2825 SW 2nd St, McMinnville, OR	2009	100%	2B/1b	34	50%	832	0	0%	\$1,400	\$1,400	\$1,400	\$1.68
			2B/2b	34	50%	918	0	0%	\$1,550	\$1,550	\$1,550	\$1.69
			Tot./Avg:	68	100%	875	0	0%	\$1,400	\$1,550	\$1,479	\$1.69
3) Evans Crossing Apts. 2501 NE Evans St, McMinnville, OR	2020	99%	1B/1b	18	15%	704	0	0%	\$1,350	\$1,350	\$1,350	\$1.92
			2B/1b	24	20%	940	1	4%	\$1,450	\$1,450	\$1,450	\$1.54
			2B/2b	77	65%	965	0	0%	\$1,575	\$1,575	\$1,575	\$1.63
			Tot./Avg:	119	100%	920	1	1%	\$1,350	\$1,575	\$1,523	\$1.65
4) Evergreen Valley 725 SE Ford St, McMinnville, OR	2020	100%	2B/2b	66	100%	952	0	0%	\$1,695	\$1,695	\$1,695	\$1.78
			Tot./Avg:	66	100%	952	0	0%	\$1,695	\$1,695	\$1,695	\$1.78
5) Lafayette Place 2349 NE Lafayette Ave, McMinnville, OR	2016	99%	1B/1b	36	27%	725	1	3%	\$1,395	\$1,395	\$1,395	\$1.92
			2B/2b	96	73%	952	0	0%	\$1,595	\$1,595	\$1,595	\$1.68
			Tot./Avg:	132	100%	890	1	1%	\$1,395	\$1,595	\$1,540	\$1.73

SOURCE: Property managers/agents, property websites, Craigslist, RealPage, CoStar, JOHNSON ECONOMICS



OCCUPANCY

All five of the surveyed properties are at least 99% occupied. In total, only three units out of 455 are currently vacant. This represents a vacancy rate of 0.7% (99.3% occupancy). This is unusually low, indicating capacity for additional supply and rent growth.

RENTS

Rents at the surveyed properties range from \$1,200 to 1,600 per month and \$1.31 to \$1.92 per square foot (PSF). The average rent level in the sample is \$1,524 per unit and \$1.66 per square foot. None of the properties currently offer any rent concessions.

With 5.0% vacancy typically regarded to represent market-clearing rent levels, the current low vacancy rates indicate that the properties are priced below market levels.

Rents are generally highest at the properties in the east, which are near highways, employment, and services. The lowest rent levels are Baker Creek Apartments, despite this being the newest project in the sample (built 2021). This property thus appears particularly underpriced. The highest rent levels are represented by Evergreen Valley (built 2020), which is located near the McMinnville Airport. Between these two properties are the three remaining properties, which all have similar rent levels. These include Valley Pointe, which is located south of Fox Ridge along SW 2nd Street. The project is somewhat dated (built 2009), but benefits from a location adjacent to the West Hills Neighborhood Park. Taking into account that this property is 100% leased, significantly higher market-clearing rents should be achievable for a new project with a similar location.

The following scatter plot displays the observed rents as a function of square footage, with each plot representing the average for a specific unit type.

FIGURE 3.6: OBSERVED COMPARABLE RENTS

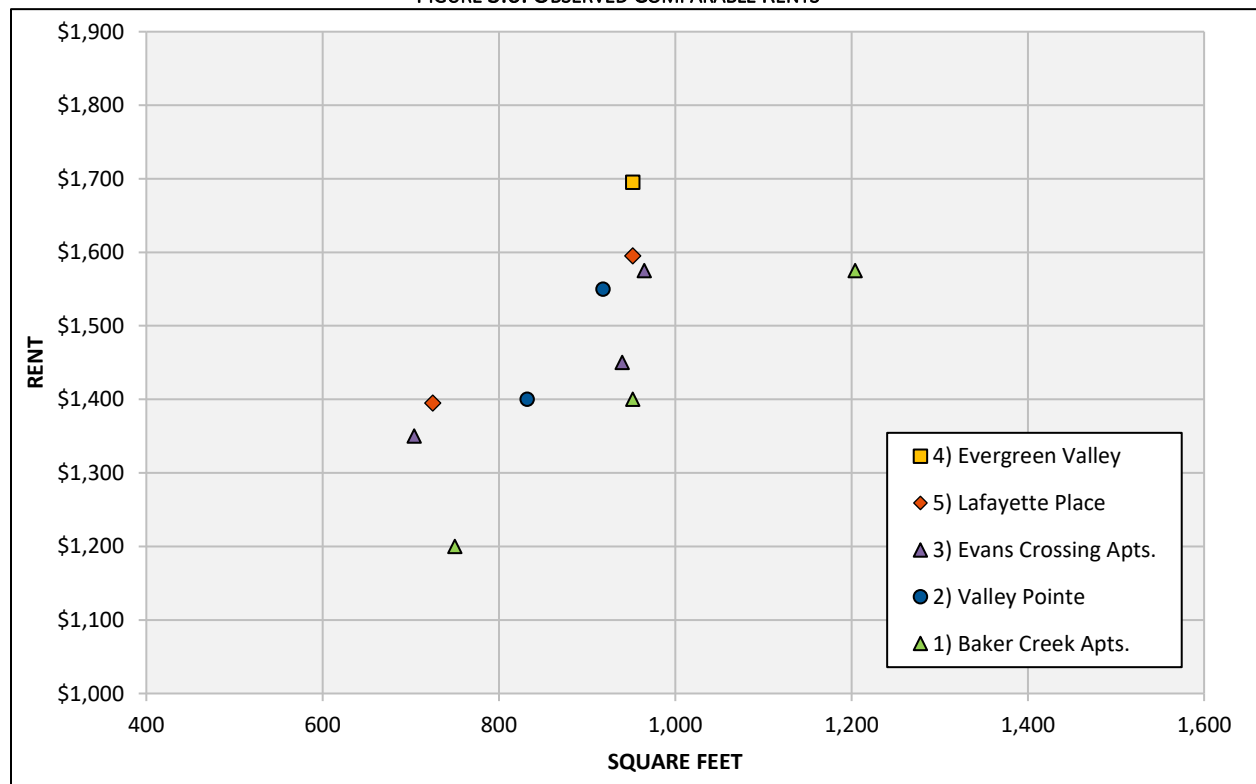

SOURCE: Property managers/agents, property websites, Craigslist, RealPage, CoStar, JOHNSON ECONOMICS



ACHIEVABLE PRICING

Achievable pricing in the Neighborhood Activity Center (NAC) will depend on the standard, profile, and amenities of the community. In the following, we assume a nearby park and on-site amenities attractive to renters, as well as a mid-market apartment profile with surface parking. Though none of the comparables include townhomes, we include rent estimates for three-bedroom townhome units based on typical rent differentials to regular apartment flats. We do not assume that a commercial center is in place at the time of lease-up, which could generate rent premiums.

With the mentioned assumptions, we would expect rental apartments within the NAC to achieve pricing in the upper end of the sample. Access to a park and commercial amenities is expected to partly offset the greater distance to employment and major commercial areas. We would expect rents below Evergreen Valley, which is a recent project with a Highway 18 location, but just above Lafayette Place, which is seven years old, though it benefits from proximity to a large commercial area (Walmart, WinCo, Safeway).

The following chart displays our rent estimates as a function of unit type and square footage, alongside rents from the comparables. Rent examples for different unit types and sizes are shown on the next page. These rates are based on market rents as of 1Q23. We would expect the achievable rent levels to move with the wider market prior to market introduction. The estimates reflect 12-month contracts with utilities billed separately.

FIGURE 3.7: OBSERVED COMPARABLE RENTS AND ACHIEVABLE PRICING

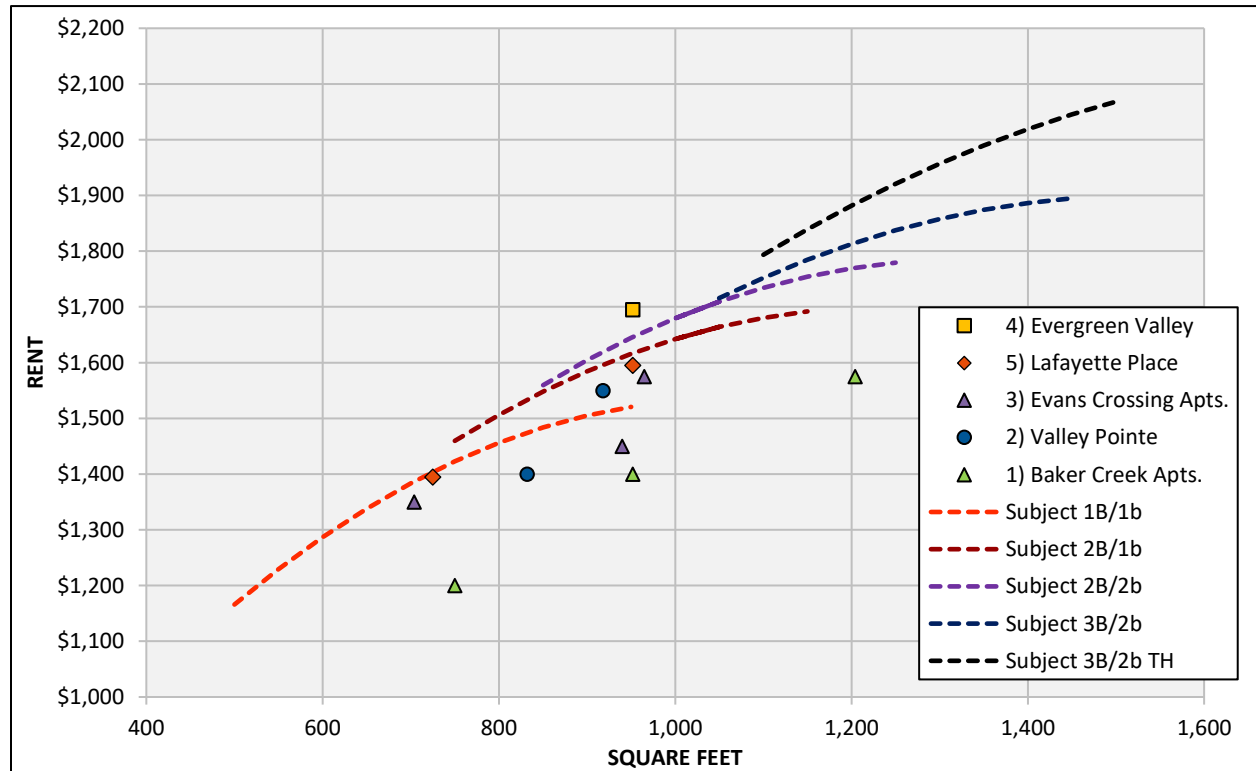

SOURCE: Property managers/agents, property websites, Craigslist, RealPage, CoStar, JOHNSON ECONOMICS

With a program consisting of one- to three-bedroom apartments ranging in size from 700 to 1,100 square feet, plus three-bedroom townhomes with 1,300 square feet (see next page), the estimates indicate monthly rent levels ranging from \$1,384 to \$1,957 per unit and \$1.51 to \$1.98 PSF. With the suggested unit mix, this translates into an average rent level of \$1,596 per unit and \$1.75 PSF. We expect this to be adequate to support traditional two and three-story walk-up structures with surface parking, but not adequate for more costly formats like elevator buildings with tuck-under or podium parking.



FIGURE 3.8: ACHIEVABLE PRICING, 1Q23

Unit Type	Units	Unit Allocation	Average Unit Size	Rent per Unit	Rent per Square Foot
1B/1b Apt	50	30%	700	\$1,384	\$1.98
2B/2b Apt	70	42%	900	\$1,604	\$1.78
3B/2b Apt	30	18%	1,100	\$1,752	\$1.59
3B/2b TH	15	9%	1,300	\$1,957	\$1.51
Total/Avg.	165	100%	912	\$1,596	\$1.75

SOURCE: JOHNSON ECONOMICS

ABSORPTION

MARKET-WIDE ABSORPTION

The historical absorption data presented earlier in this section reflected annual net absorption of around 140 units in the two most recent years with significant amounts of new supply. According to Costar, 137 units were absorbed on a net basis in 2017, when 132 new units were delivered (Lafayette Place) and the city-wide vacancy rate averaged 3.3%. In 2020, 142 units were absorbed when 119 units were delivered and the vacancy rate averaged 2.2%.

The current vacancy rate in McMinnville is 1.2%, according to CoStar. This additional market pressure indicates that absorption higher than 140 units can be achieved, assuming adequate supply.

According to the Census Bureau, there are 2,600 rental apartment households in McMinnville currently. At the current vacancy rate, these households can absorb 165 additional units before the vacancy rate climbs above the 5.0% that represents a balanced market. Additionally, with a current vacancy rate around 1.0%, there is also significant pent-up demand from prospective renters unable to find units that match their needs. Thus, we would expect the current annual absorption potential to be well above 200 units, not taking into account new demand from population growth.

According to the most recent Housing Needs Analysis (HNA) conducted for the City of McMinnville (ECONorthwest, 2019), population growth in the city is projected to generate a need for 75 new multifamily units (mostly apartments) annually in coming years. Demand for other housing forms is projected to grow by roughly 150 units annually. The total housing need is thus estimated to grow by around 225 units per year. Over the past 15 years, the city has only been able to produce housing at this level once, in 2019, based on issued building permits. Over the past five years, the new housing supply has averaged roughly 175 units annually. In markets with undersupply of housing, the unmet demand typically filters down to the least costly housing form (rental apartments) as the least affluent households are priced out of the more expensive housing forms. Thus, it is not unlikely that McMinnville in coming years will see additional apartment demand from an undersupplied single-family market. The potential market-wide apartment absorption may therefore be higher than the 75 units annually indicated by the HNA.

Demand for attached homes is estimated to grow by 27 units annually, according to the HNA. We will assume that 50% of this will be for rental units, indicating annual absorption of around 15 attached rental homes (the current rental percentage in this category is 71%, according to Census Bureau, but includes renter-occupied for-sale homes).

SUBJECT SITE ABSORPTION

Given the current demand pressures, we would expect a single-phase apartment project in McMinnville to absorb up to 200 units annually in the current market. If additional supply were to ease the pressures to the point where the market-wide vacancy rate reaches 5.0%, we would assume that around 100 units could be absorbed annually. As McMinnville's vacancy rate has stayed well below 4.0% since 2013, we regard the latter scenario to be unlikely. We therefore expect a project with around 150 apartments to be feasible in the NAC with an absorption period of around 12 months in coming years. Additionally, we would assume that around 15 rental townhomes can be absorbed annually. We would assume that up to 300 apartments and 30 townhomes may be feasible over a period of three to four years, assuming two-phase approach with one to two years of stabilized phase-one operations.



IV. OWNERSHIP HOUSING

MARKET TRENDS

SALES VELOCITY

Detached single-family homes currently account for 94% of all home sales in McMinnville, while attached homes account for 6%. The latter made up roughly 10% of all sales transactions early in the last decade. Based on records from the Regional Multiple Listing System (RMLS), the total sales volume has been fairly stable at around 500 transactions per year over the past 10 years.

The stable sales pace masks the increase in demand that has taken place over this period. This is evident in the decline in market time for listed units. In 2013 the median time between listing and sale was 68 days. By 2021, the median had fallen to 6 days. There was a slight increase to 10 days in 2022, and sales so far in 2023 indicate a continued increase, reflecting the impact of higher mortgage rates. Attached homes have generally sold quicker than detached homes over the past decade, though there has been little difference between the two in recent years. A median market time of 60-90 days is generally considered to represent a balanced market in terms of supply and demand.

FIGURE 4.1: OWNERSHIP HOUSING SALES AND MEDIAN DAYS ON THE MARKET (2013-22)

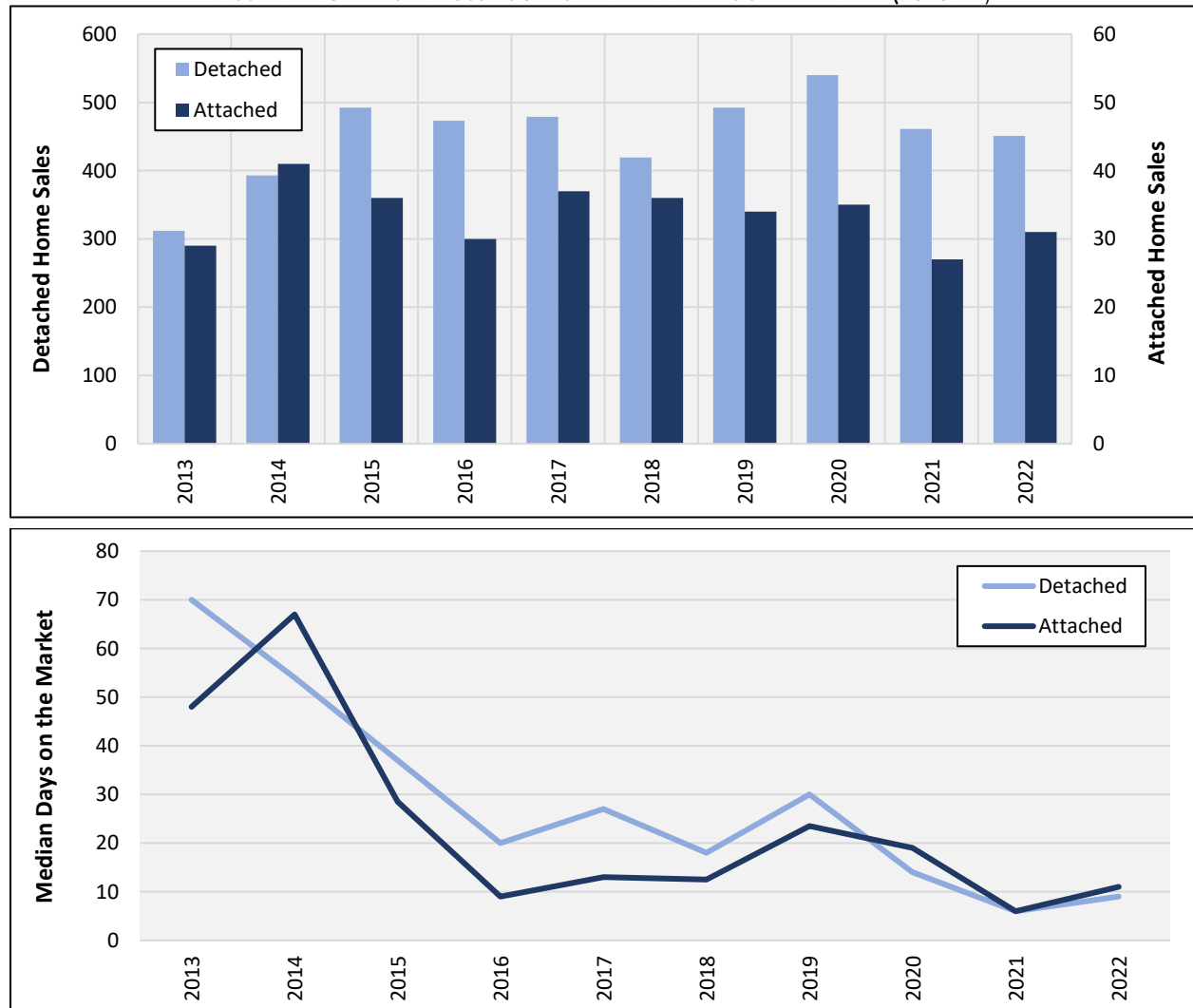

SOURCE: RMLS, JOHNSON ECONOMICS



SALES PRICES

Sales prices in McMinnville have risen rapidly over the past 10 years, as they have all across the Pacific Northwest. Attached homes have seen the strongest gains, with an average annual price increase of 11.6%. This might reflect that attached home values were more depressed in the wake of the 2008-09 recession due to the loss of demand from young buyers. Detached homes have gained 10.1% annually over the same period. Median prices in 2022 were \$453,000 for detached homes and \$369,000 for attached homes. On per-square-foot (PSF) basis, the median was \$280 for detached homes and \$264 for attached homes.

FIGURE 4.2: OWNERSHIP HOUSING PRICE TRENDS (2013-22)

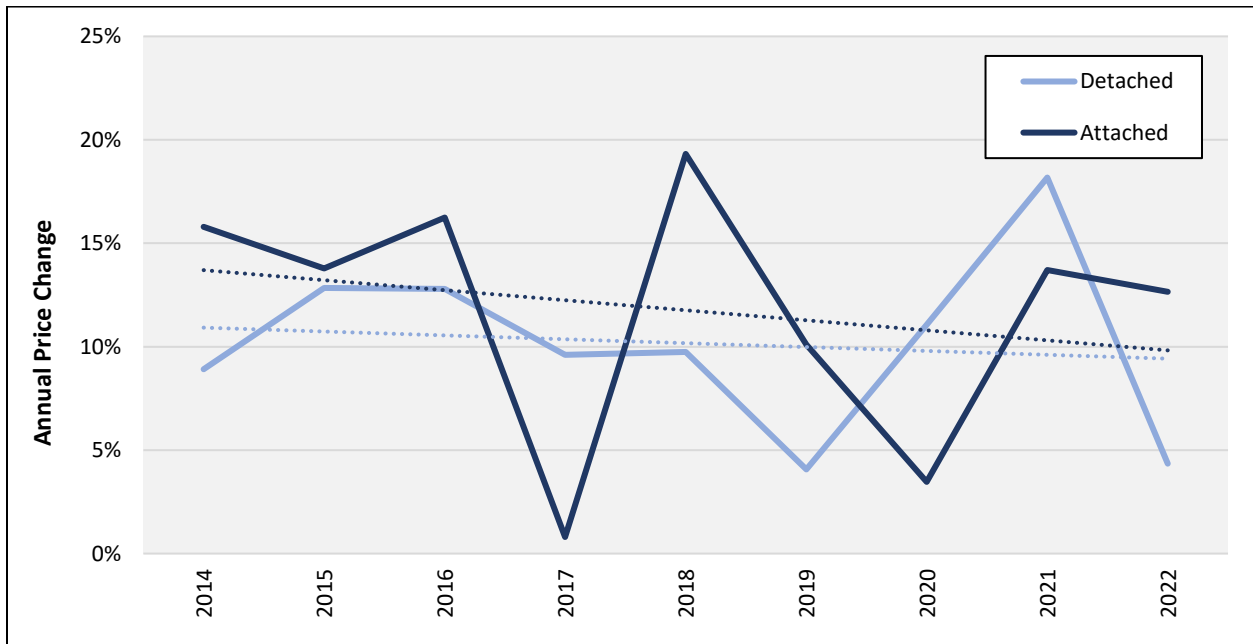
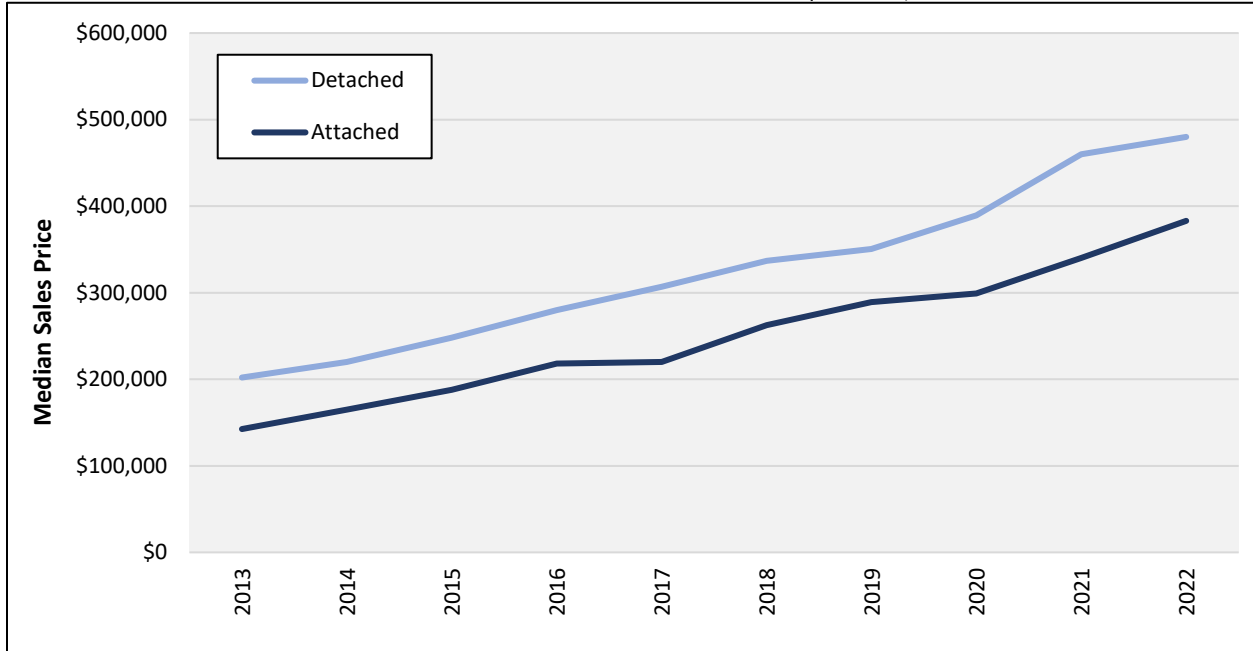

SOURCE: RMLS, JOHNSON ECONOMICS



SURVEY OF COMPARABLES

COMPARABLES

JOHNSON ECONOMICS surveyed five subdivisions in McMinnville for this analysis. Three are suburban, two-story townhome projects, built out between 2004 and 2009 (#1-3). In the following pricing analysis, we will rely on resale transactions within these subdivisions. Due to the lack of more recent townhome projects, we have included two recent detached-home projects near the Fox Ridge area (#4-5). We will use new-home transactions from these projects in order to provide additional pricing references for townhomes, taking into account typical price differentials between the two housing types. The following map shows the locations of the surveyed subdivisions.

Details on each project is included over the next pages. We have included the most recent sales transactions within each subdivision, with estimates of current value based on trended price estimates, using an index of monthly median sales prices in Yamhill County (the county dataset reflects the same price trend as McMinnville, but with more data points and less random fluctuations).

FIGURE 4.3: MAP OF SURVEYED SUBDIVISIONS

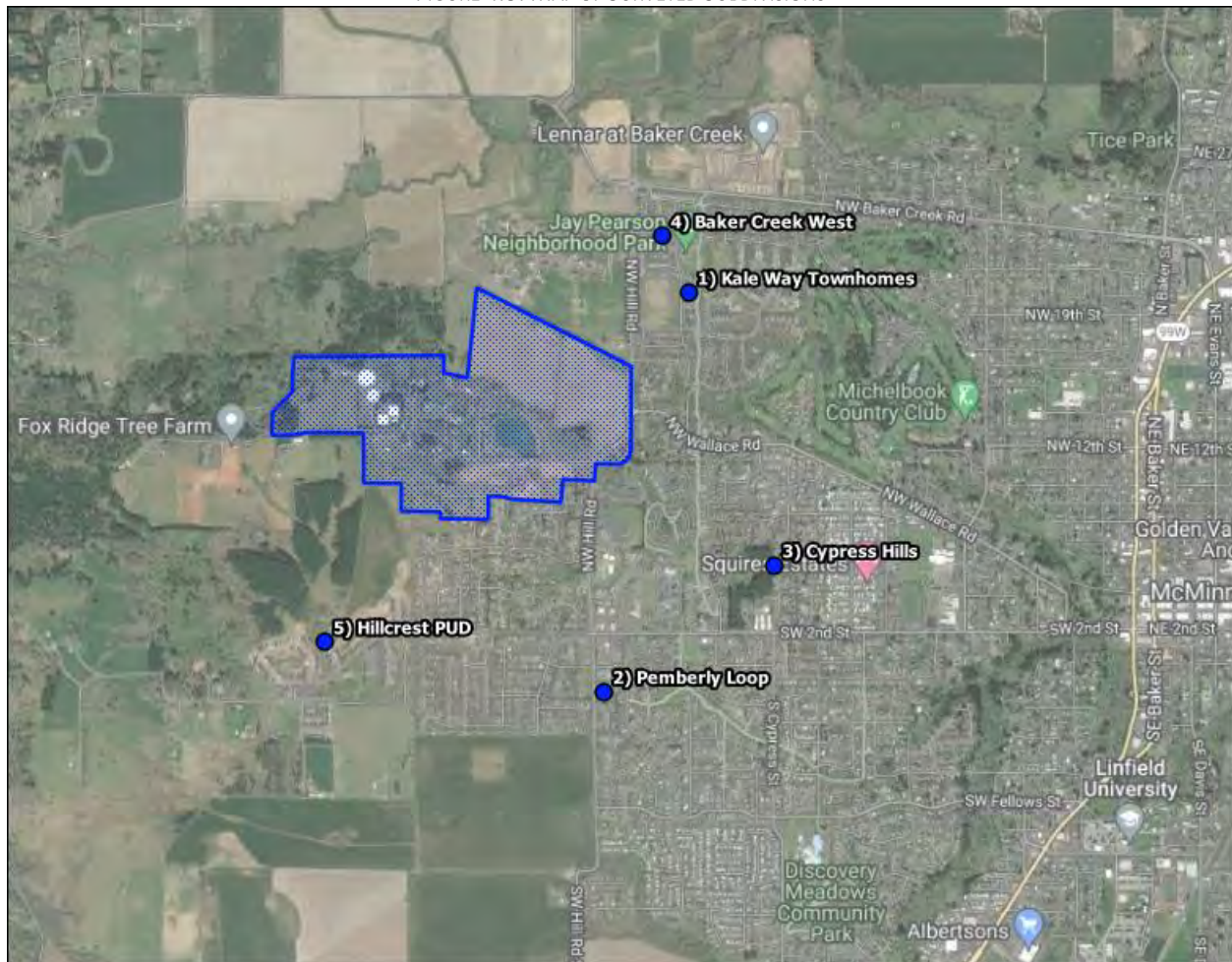

SOURCE: JOHNSON ECONOMICS





FIGURE 4.4: PROFILES OF SURVEYED SUBDIVISIONS

1 - KALE WAY TOWNHOMES

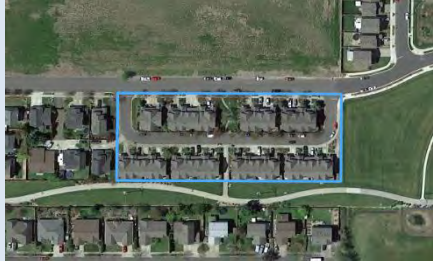
NW Yohn Ranch Dr, NW Kale Way, McMinnville, Oregon







TYPE: 2-Story Townhomes

YEAR BUILT: 2006-07

TOTAL LOTS: 27

AVERAGE LOT SIZE: 2,139

AVERAGE PRICE/SF: \$238

Community Amenities

Adjacent park w/playground
Walking trail
(No HOA fees)

Typical Unit Amenities

Laminate plank, carpet, vinyl floors
Granite and laminate countertops
Walk-in pantry
Stainless appliances
Patio, A/C

Street Address	Lot Size (SF)	BUILDING DETAILS			SALES PRICE & CURRENT VALUE			
		Size (SF)	Beds	Baths	Date	Price (\$)	Curr. Value	\$/SF
1952 Nw Yohn Ranch	2,178	1,444	2	2.1	10/28/2022	\$379,000	\$356,017	\$247
2022 Nw Kale Way	2,613	1,359	2	2.1	7/22/2022	\$380,000	\$340,792	\$251
2000 Nw Yohn Ranch	2,178	1,444	3	2.1	6/8/2021	\$325,000	\$323,233	\$224
2050 Nw Yohn Ranch	2,178	1,431	3	2.1	4/9/2021	\$315,000	\$326,241	\$228
2006 Nw Kale Way	2,613	1,444	3	2.1	8/31/2020	\$295,000	\$332,860	\$231

2 - PEMBERLY LOOP

SW Pemberly Loop, McMinnville, Oregon







TYPE: 2-Story Townhomes

YEAR BUILT: 2007-09

TOTAL LOTS: 21

AVERAGE LOT SIZE: 2,607

AVERAGE PRICE/SF: \$206

Community Amenities

(HOA fees: \$75/mo.)

Typical Unit Amenities

Laminate, tile, carpet flooring
Tile, laminate countertops
Black appliances
Gas fireplace
Vaulted ceilings, A/C, patio

Street Address	Lot Size (SF)	BUILDING DETAILS			SALES PRICE & CURRENT VALUE			
		Size (SF)	Beds	Baths	Date	Price (\$)	Curr. Value	\$/SF
416 Sw Pemberly Loc	4,791	1,930	3	2.1	7/29/2022	\$425,000	\$381,149	\$197
339 Sw Pemberly Loc	2,178	1,503	3	2.1	3/11/2022	\$355,000	\$328,698	\$219
336 Sw Pemberly Loc	1,742	1,597	3	2.1	11/15/2021	\$357,000	\$348,977	\$219
417 Sw Pemberly Loc	2,178	1,732	3	2.1	3/25/2021	\$329,000	\$347,780	\$201
433 Sw Pemberly Loc	2,178	1,732	3	2.1	12/28/2020	\$299,150	\$325,612	\$188
423 Sw Pemberly Loc	2,178	1,732	3	2.1	4/15/2020	\$300,000	\$352,613	\$204



3 - CYPRESS HILLS

NW Cypress St at W 6th St, McMinnville, Oregon

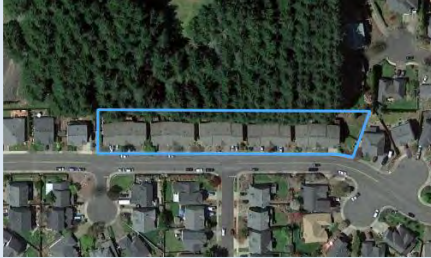

TYPE: 2-Story Townhomes
YEAR BUILT: 2004
TOTAL LOTS: 20
AVERAGE LOT SIZE: 2,591
AVERAGE PRICE/SF: \$239

Community Amenities

Backing forested hill
 (No HOA fees)

Typical Unit Amenities

Laminate plank, carpet, vinyl flooring
 Laminate countertops
 White appliances, el. range
 Vaulted ceilings, split level entry
 Deck

Street Address	Lot Size (SF)	BUILDING DETAILS			SALES PRICE & CURRENT VALUE			
		Size (SF)	Beds	Baths	Date	Price (\$)	Curr. Value	\$/SF
527 Nw Cypress St	2,613	1,480	3	2.1	2/3/2023	\$380,000	\$380,000	\$257
675 Nw Cypress St	1,742	1,306	2	2.1	5/27/2022	\$379,500	\$340,178	\$260
563 Nw Cypress St	2,613	1,480	3	2.1	7/2/2021	\$338,000	\$332,697	\$225
575 Nw Cypress St	2,613	1,480	3	2.1	5/24/2021	\$340,000	\$345,049	\$233
511 Nw Cypress St	1,742	1,308	2	2.0	2/1/2019	\$243,000	\$305,657	\$234
667 Nw Cypress St	2,613	1,480	3	2.1	10/19/2018	\$265,000	\$336,751	\$228

4 - BAKER CREEK WEST

NW Baker Creek Rd & NW Hill Rd, McMinnville, Oregon

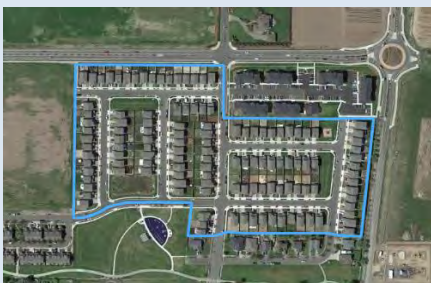

TYPE: 2-Story Detached
YEAR BUILT: 2019+
TOTAL LOTS: 125
TYPICAL LOT SIZE: 4,000
AVERAGE PRICE/SF: \$269

Community Amenities

Neighborhood park
 Playground
 Trails
 (HOA fees: \$28/mo.)

Typical Unit Amenities

Laminate plank, carpet flooring
 Quartz/tile countertops
 Stainless appliances, kitchen island
 Gas fireplace/range, walk-in closet
 9-foot ceilings, A/C

Street Address	Lot Size (SF)	BUILDING DETAILS			SALES PRICE & CURRENT VALUE			
		Size (SF)	Beds	Baths	Date	Price (\$)	Curr. Value	\$/SF
1939 Nw Haun Dr	3,049	1,532	3	2.1	2/10/2023	\$429,000	\$429,000	\$280
2276 Nw Woodland C	3,049	1,525	3	2.1	1/27/2023	\$420,000	\$423,776	\$278
2003 Nw 21St St	3,049	1,526	3	2.1	9/15/2022	\$442,000	\$406,946	\$267
2398 Nw Matteo Dr	3,484	1,498	3	2.1	6/30/2022	\$435,500	\$388,016	\$259
1984 Nw 21St St	3,049	1,498	3	2.1	5/20/2022	\$440,000	\$394,409	\$263
2316 Nw Matteo Dr	3,484	1,498	3	2.1	3/30/2022	\$424,000	\$392,585	\$262



5 - HILLCREST PD (PART)

SW 2nd St, Valley's Edge St, NW Brookside St, McMinnville, Oregon



TYPE: 1- & 2-Story Detached
YEAR BUILT: 2019+
TOTAL LOTS: 94
TYPICAL LOT SIZE: 9,000
AVERAGE PRICE/SF: \$281

Community Amenities

Neighborhood Park
 Playground
 Views
 (No HOA fees)

Typical Unit Amenities

Hardwood, laminate, carpet flooring
 Stone countertops
 Stainless appliances, kitchen island
 Gas fireplace/range
 9-foot ceilings, A/C, deck

Street Address	Lot Size (SF)	BUILDING DETAILS			SALES PRICE & CURRENT VALUE			
		Size (SF)	Beds	Baths	Date	Price (\$)	Curr. Value	\$/SF
2837 Nw Mt Ashland Ln	6,969	2,548	4	2.1	1/31/2023	\$650,000	\$655,844	\$257
2893 Nw Mt Ashland Ln	6,969	2,538	4	2.1	1/3/2023	\$703,900	\$710,229	\$280
2999 Nw 2Nd St	12,632	1,620	3	2.0	12/8/2022	\$525,000	\$521,284	\$322
2842 Nw Mt Ashland Ln	8,276	2,727	4	2.1	12/5/2022	\$650,000	\$645,399	\$237
2848 Nw Mt Ashland Ln	8,276	2,504	4	2.1	11/23/2022	\$650,000	\$626,073	\$250
115 Sw Blue Heron Ct	8,276	1,729	4	2.1	10/31/2022	\$499,900	\$469,586	\$272

SOURCE: RMLS, Yamhill County, Google Earth, JOHNSON ECONOMICS



FIGURE 4.5: RECENT HOME SALES SUMMARY, SURVEYED SUBDIVISIONS

SUBDIVISION	Location	Property Address	Lot Size (SF)	HOME TYPE			HOME PRICES				
				Size (SF)	Beds	Baths	Date	Price (\$)	Curr. Value	\$/SF	
1) Kale Way Townh.		1952 Nw Yohn Ranch Dr	2,178	1,444	2	2.1	10/28/2022	\$379,000	\$356,017	\$247	
		NW Yohn Ranch Dr	2022 Nw Kale Way	2,613	1,359	2	2.1	7/22/2022	\$380,000	\$340,792	\$251
		NW Kale Way	2000 Nw Yohn Ranch Dr	2,178	1,444	3	2.1	6/8/2021	\$325,000	\$323,233	\$224
		McMinnville, OR	2050 Nw Yohn Ranch Dr	2,178	1,431	3	2.1	4/9/2021	\$315,000	\$326,241	\$228
			2006 Nw Kale Way	2,613	1,444	3	2.1	8/31/2020	\$295,000	\$332,860	\$231
		Townhomes, 2006-07	2030 Nw Yohn Ranch Dr	2,178	1,359	2	2.1	8/2/2019	\$275,000	\$337,239	\$248
2) Pemberly Loop		416 Sw Pemberly Loop	4,791	1,930	3	2.1	7/29/2022	\$425,000	\$381,149	\$197	
		SW Pemberly Loop	339 Sw Pemberly Loop	2,178	1,503	3	2.1	3/11/2022	\$355,000	\$328,698	\$219
		McMinnville, OR	336 Sw Pemberly Loop	1,742	1,597	3	2.1	11/15/2021	\$357,000	\$348,977	\$219
			417 Sw Pemberly Loop	2,178	1,732	3	2.1	3/25/2021	\$329,000	\$347,780	\$201
		Townhomes, 2007-09	433 Sw Pemberly Loop	2,178	1,732	3	2.1	12/28/2020	\$299,150	\$325,612	\$188
3) Cypress Hills		527 Nw Cypress St	2,613	1,480	3	2.1	2/3/2023	\$380,000	\$380,000	\$257	
		NW Cypress St	675 Nw Cypress St	1,742	1,306	2	2.1	5/27/2022	\$379,500	\$340,178	\$260
		McMinnville, OR	563 Nw Cypress St	2,613	1,480	3	2.1	7/2/2021	\$338,000	\$332,697	\$225
			575 Nw Cypress St	2,613	1,480	3	2.1	5/24/2021	\$340,000	\$345,049	\$233
		Townhomes, 2004	511 Nw Cypress St	1,742	1,308	2	2.0	2/1/2019	\$243,000	\$305,657	\$234
4) Baker Creek West		1939 Nw Haun Dr	3,049	1,532	3	2.1	2/10/2023	\$429,000	\$429,000	\$280	
		NW Baker Creek Rd	2276 Nw Woodland Dr	3,049	1,525	3	2.1	1/27/2023	\$420,000	\$423,776	\$278
		NW Hill Rd	2003 Nw 21St St	3,049	1,526	3	2.1	9/15/2022	\$442,000	\$406,946	\$267
		McMinnville, OR	2398 Nw Matteo Dr	3,484	1,498	3	2.1	6/30/2022	\$435,500	\$388,016	\$259
			1984 Nw 21St St	3,049	1,498	3	2.1	5/20/2022	\$440,000	\$394,409	\$263
		SF Detached, 2019+	2316 Nw Matteo Dr	3,484	1,498	3	2.1	3/30/2022	\$424,000	\$392,585	\$262
5) Hillcrest PD		2837 Nw Mt Ashland Ln	6,969	2,548	4	2.1	1/31/2023	\$650,000	\$655,844	\$257	
		SW 2nd St	2893 Nw Mt Ashland Ln	6,969	2,538	4	2.1	1/3/2023	\$703,900	\$710,229	\$280
		Valley's Edge St	2999 Nw 2Nd St	12,632	1,620	3	2.0	12/8/2022	\$525,000	\$521,284	\$322
		McMinnville, OR	2842 Nw Mt Ashland Ln	8,276	2,727	4	2.1	12/5/2022	\$650,000	\$645,399	\$237
			2848 Nw Mt Ashland Ln	8,276	2,504	4	2.1	11/23/2022	\$650,000	\$626,073	\$250
		SF Detached, 2019+	2842 Nw Mt Ashland Ln	8,276	2,727	4	2.1	12/5/2022	\$650,000	\$645,399	\$237

SOURCE: RMLS, Yamhill County, JOHNSON ECONOMICS

Adjusted to current values, the most recent sales transactions at the surveyed projects range from around \$243,000 to \$710,000 per home and \$188 to \$322 per square foot (PSF). The average value is \$412,000 per home and \$243 PSF.

The three townhome projects represent the lowest current values, reflecting the housing form and that these are resale transactions of homes built in the 2000s. The lowest values are represented by Pemberly Loop, which is the only of the townhome projects with HOA fees (\$75/mo.). Hillcrest, which is without HOA fees, represents the highest values, also when adjusted for home size. This reflects its detached-home format, its relatively upscale home features, and its large share of single-story homes – which sell at a premium on PSF basis. The following scatter plot displays the sales prices adjusted to current levels as a function of square footage.



FIGURE 4.6: RECENT SALES PRICES ADJUSTED TO CURRENT LEVELS, SURVEYED SUBDIVISIONS

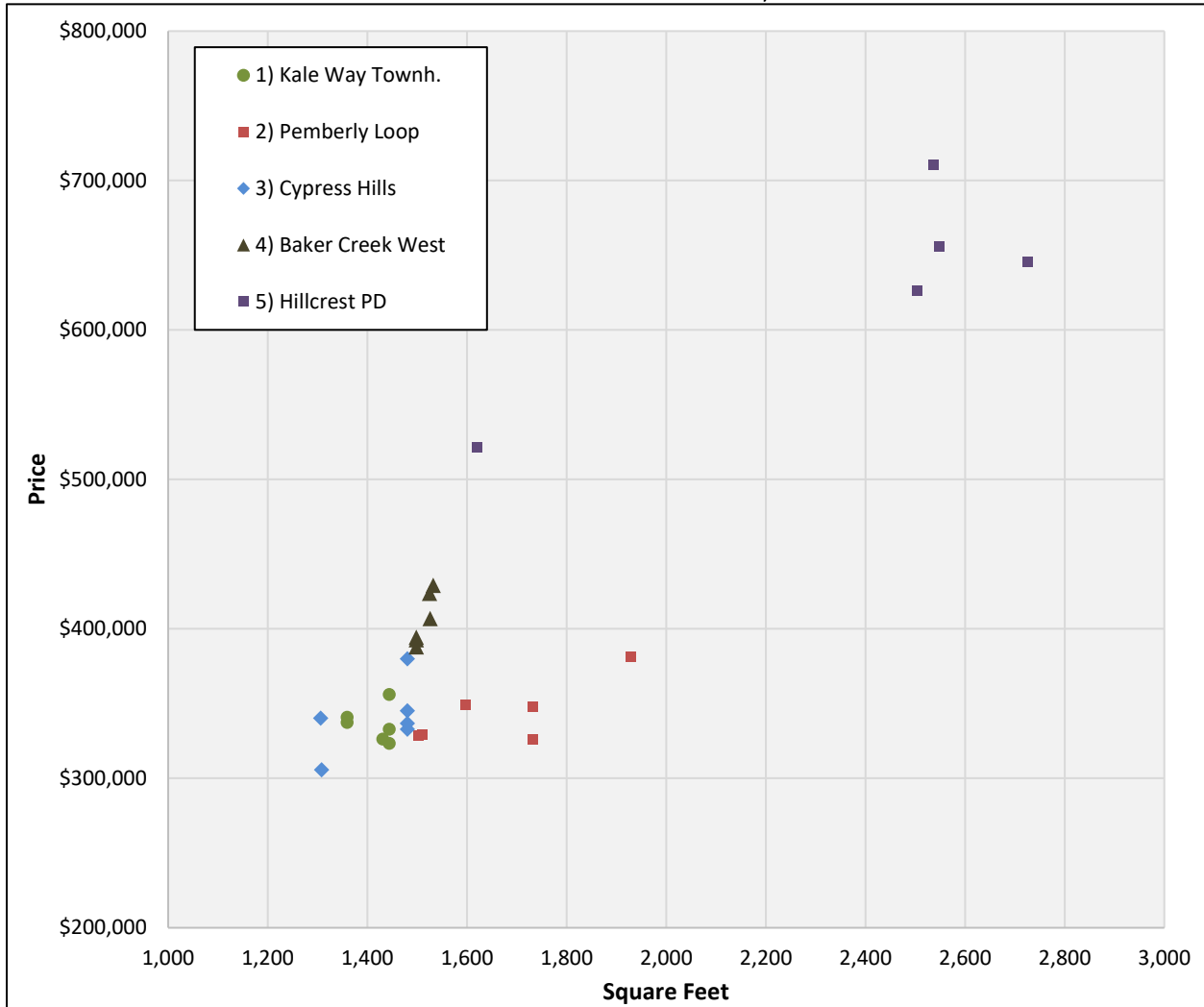

SOURCE: RMLS, Yamhill County, JOHNSON ECONOMICS

ACHIEVABLE PRICING

Achievable pricing in the NAC will depend on the standard, profile, and amenities of the community, as well as parks and amenities at the site. In the following, we make the same assumptions as for the rental housing regarding amenities and market positioning. These include the assumption that no commercial amenities will be in place at time of sale.

In order to assist the process of estimating achievable pricing, we first adjust the detached-home values from Hillcrest and Baker Creek West to be representative of townhomes. For this, we rely on price differentials observed by JOHNSON ECONOMICS in detailed analyses of master plan projects with multiple housing forms. We generally observe discounts of 5-15% for suburban townhomes relative to detached homes of similar size and features. The discount depends on the lot size and width of the homes.

For the detached homes at Baker Creek West, we apply a 7% discount, due to the relatively small lots and narrow homes. At Hillcrest, which has much larger lots and wider homes, we apply a 20% discount in order to also account for its single-story homes and relatively upscale features, which exceed our mid-market assumptions for the NAC.



The following chart displays our estimates of achievable townhome pricing in today’s market in the NAC, alongside the current values at the comparables – including the adjusted detached-home values. We assume pricing above the three townhome projects, due to their age (built 2004-09), but in line with the values adjusted to reflect townhome pricing at Baker Creek West and Hillcrest.

FIGURE 4.7: ADJUSTED COMPARABLE PRICING AND ACHIEVABLE SUBJECT PRICING

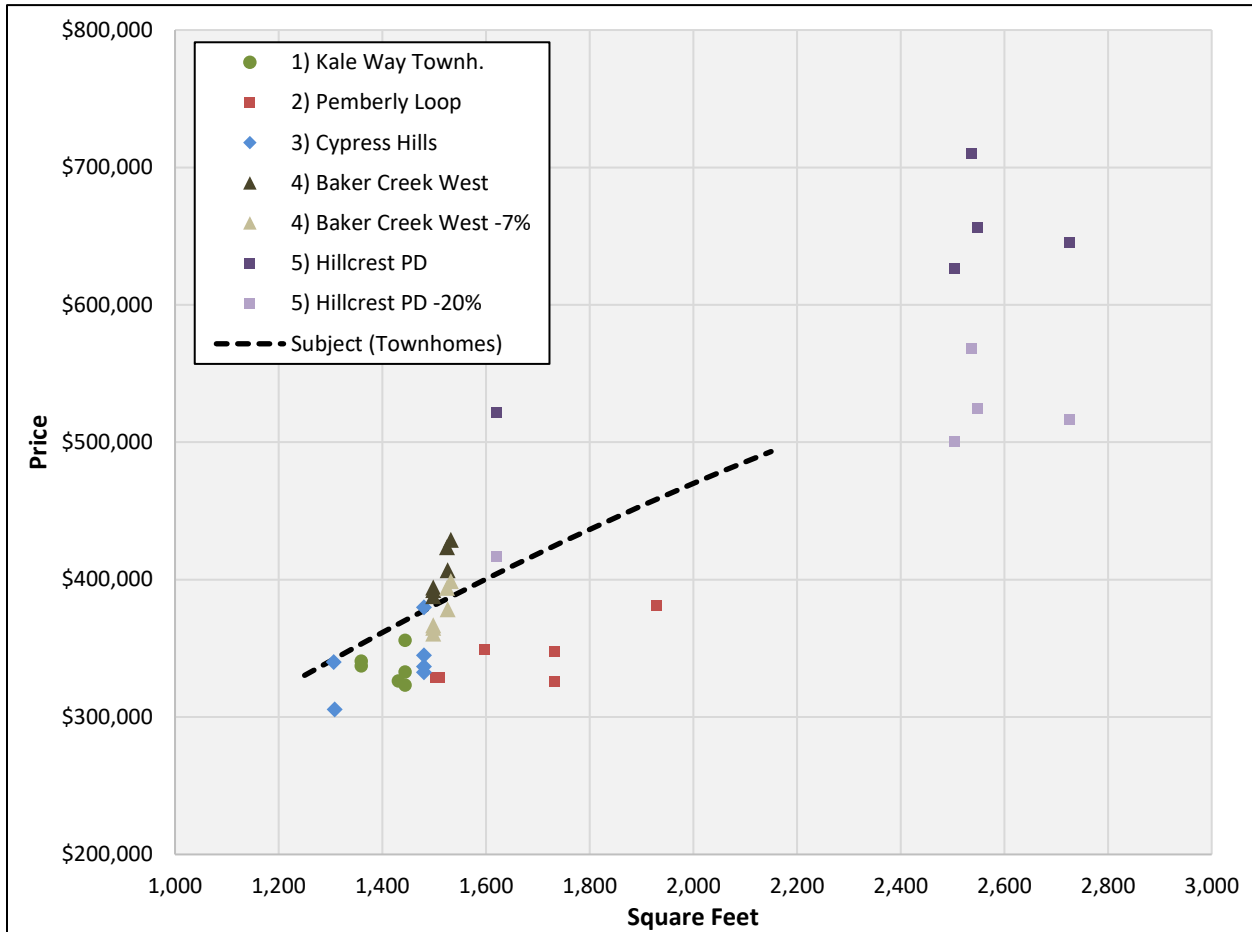

SOURCE: RMLS, Yamhill County, JOHNSON ECONOMICS

With two- and three-bedroom townhomes ranging in size from 1,400 to 1,800 square feet, the analysis indicates achievable pricing ranging from around \$360,000 to \$440,000, or \$243-258 PSF. With the following mix, which is estimated to represent a two-year absorption period (see next page), this translates into an average home price of around \$400,000 per home and \$250 PSF. This is likely adequate for suburban townhomes with a mid-market profile.

FIGURE 4.8: ACHIEVABLE OWNERSHIP PRICING, 1Q23

2-STORY TH.	UNIT MIX				PRICING		
	Type	Units (#)	Units (%)	Home Size	Lot Size	Per Home	Per SF
	2B/2.5b	10	33%	1,400	2,000	\$361,400	\$258
	3B/2.5b	10	33%	1,600	2,500	\$400,400	\$250
	3B/2.5b	10	33%	1,800	3,000	\$436,600	\$243
	Total	30	100%	1,600	2,500	\$399,467	\$250

SOURCE: JOHNSON ECONOMICS



ABSORPTION

As discussed in the section on rental housing, the most recent Housing Needs Analysis for McMinnville includes a projected need for 27 attached single-family homes annually, which we assume will be split 50/50 between rentals and ownership. Thus, we assume a city-wide absorption potential of roughly 15 for-sale townhomes and duplexes per year. Given the very limited supply of new attached homes in McMinnville in recent years, we would assume that the NAC can capture all of this demand, absorbing around 15 townhomes annually.



V. COMMERCIAL SPACE

MARKET TRENDS

The retail market in McMinnville has seen limited development activity in recent years. According to CoStar, 2006 was the last year with a significant amount of new space delivered, when 81,000 square feet were completed. Over the past 10 years, only 34,000 square feet have been completed, reflecting limited demand due to increasing online competition. However, 87,000 square feet have been absorbed on a net basis over this period, suggesting stronger demand than reflected in the development activity. This has eaten into the inventory of vacant space in the city.

The net absorption has been uneven in recent years, with declines in 2019 and 2020 followed by gains in 2021 and 2022. Roughly 20,000 square feet were absorbed on a net basis in each of the last two years, above the annual average of 8,700 square feet over the past 10 years.

FIGURE 5.1: RETAIL DELIVERIES AND NET ABSORPTION (2006-22)

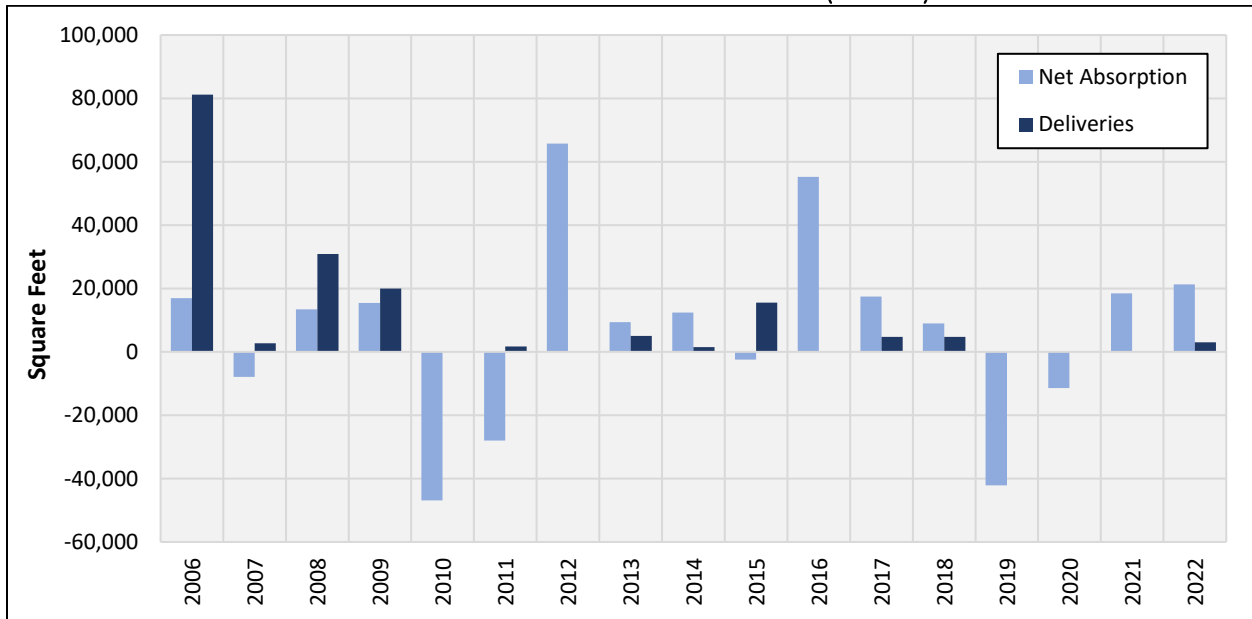

SOURCE: CoStar, JOHNSON ECONOMICS

The small size of the McMinnville market leads to wide fluctuations in the vacancy rate when spaces are vacated or become occupied. However, the city has generally exhibited low vacancy over the past decade – lower than in the Portland Metro and Salem Metro markets (see chart next page). The rate peaked at 7.3% in 2011, and thereafter fell to 1.0% in early 2019. This is unusually low. The rate rose again early in COVID, but has since fallen back to 1.8% as of year-end 2022. This is on par with the Salem Metro vacancy rate, but well below the Portland Metro rate. The low vacancy rate indicates potential for additional supply.



FIGURE 5.2: RETAIL VACANCY, GEOGRAPHIC COMPARISON (2006-22)

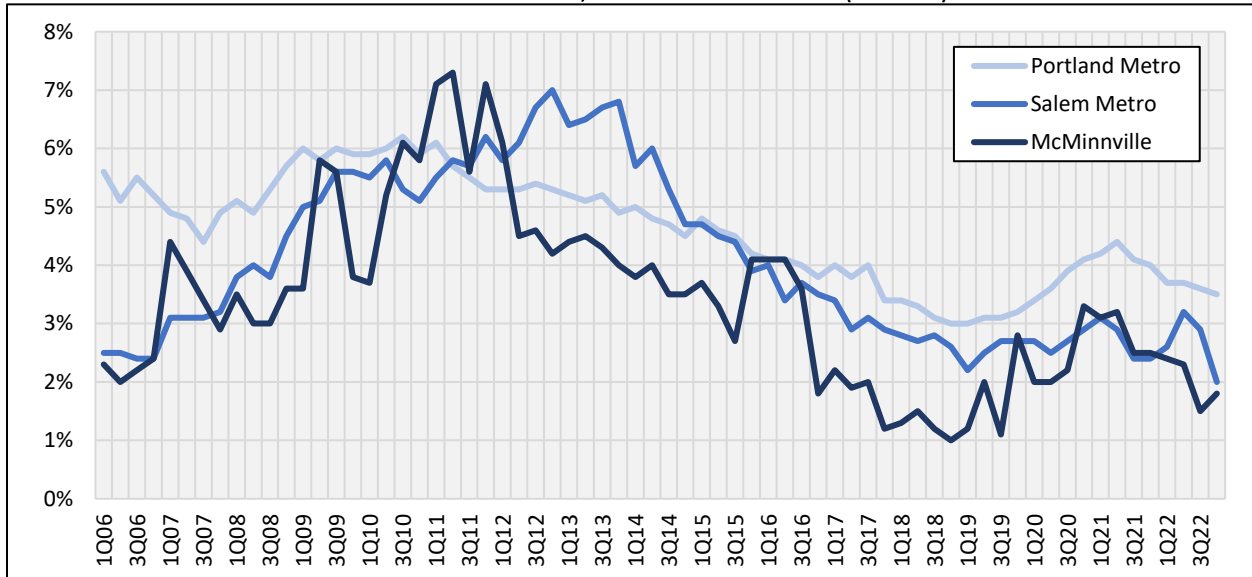

SOURCE: CoStar, JOHNSON ECONOMICS

Average lease rates reported by CoStar will reflect the space available for lease at any given time. In McMinnville, the average rate has generally exceeded the average in the Salem Metro Area, but been lower than in the Portland Metro Area. The McMinnville average trended higher at a relatively rapid pace during the second half of the last decade, and thereafter saw more moderate gains over the 2020-22 period, before falling to \$17.36 at year-end 2022. This recent decline may be a function of short-term fluctuations rather than underlying market softness. If we follow the trendline, the market has averaged 5.9% annual rent growth over the past five years. If we use the actual quarterly averages, the annual rent growth was 1.6%. The average of the two (3.8%) is identical to general inflation over this period. In comparison, Portland Metro averaged 2.1% annual rent growth while Salem Metro averaged 3.1% annually over this period.

FIGURE 5.3: AVERAGE ASKING RETAIL RATE (NNN), GEOGRAPHIC COMPARISON (2006-22)

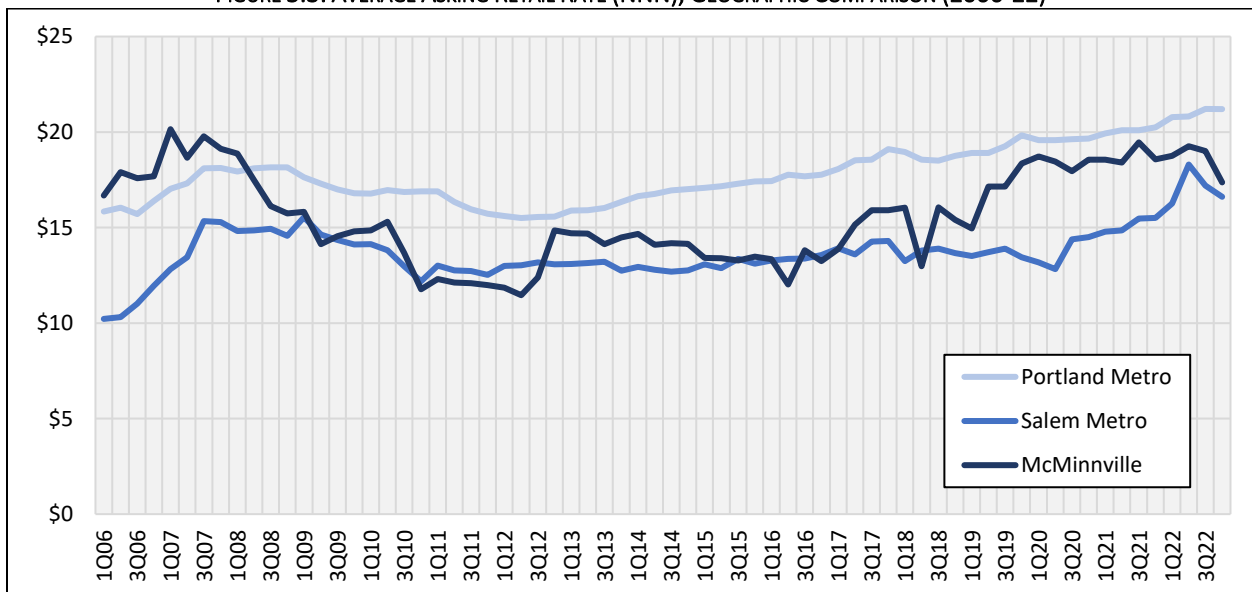

SOURCE: CoStar, JOHNSON ECONOMICS



SURVEY OF COMPARABLES

COMPARABLES

Recent commercial projects in McMinnville are few in number and generally located along Highway 99 or in Downtown, both of which represent stronger environments for commercial uses than the subject site. In our survey of comparables, we have therefore focused on suburban retail properties with a neighborhood orientation. We have included two such properties near the subject site on NW Hill Road in McMinnville. These were built in 1990 and 2009.

In order to provide reference points from newer projects, we have included four newer properties from other parts of the Portland-Salem region that represent locations somewhat similar to the subject site. However, it should be mentioned that there are few examples of recent commercial developments along roads with traffic volumes comparable to the subject site (3,200 AADT in 2021). The four properties included from outside McMinnville have daily traffic volumes ranging from 10,000 to 20,000, and are located in Salem, Beaverton, and Felida (unincorporated Clark County, Washington). Maps from each of these areas are included over the next pages, followed by profiles of the retail properties.

FIGURE 5.4: MAP OF SURVEYED RETAIL COMPARABLES, MCMINNVILLE

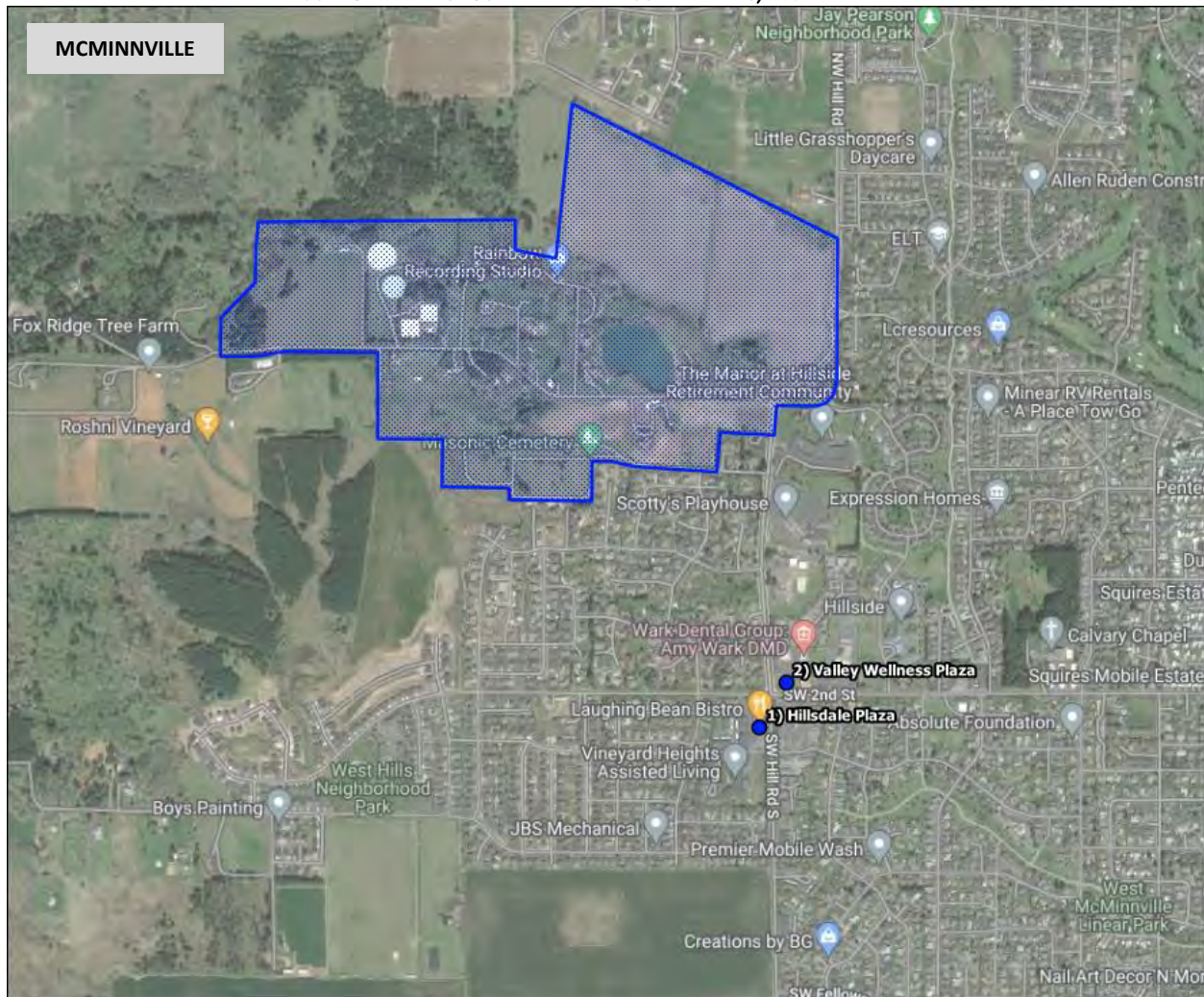

SOURCE: Google Earth, JOHNSON ECONOMICS



FIGURE 5.5: MAP OF SURVEYED RETAIL COMPARABLES, SALEM AND BEAVERTON

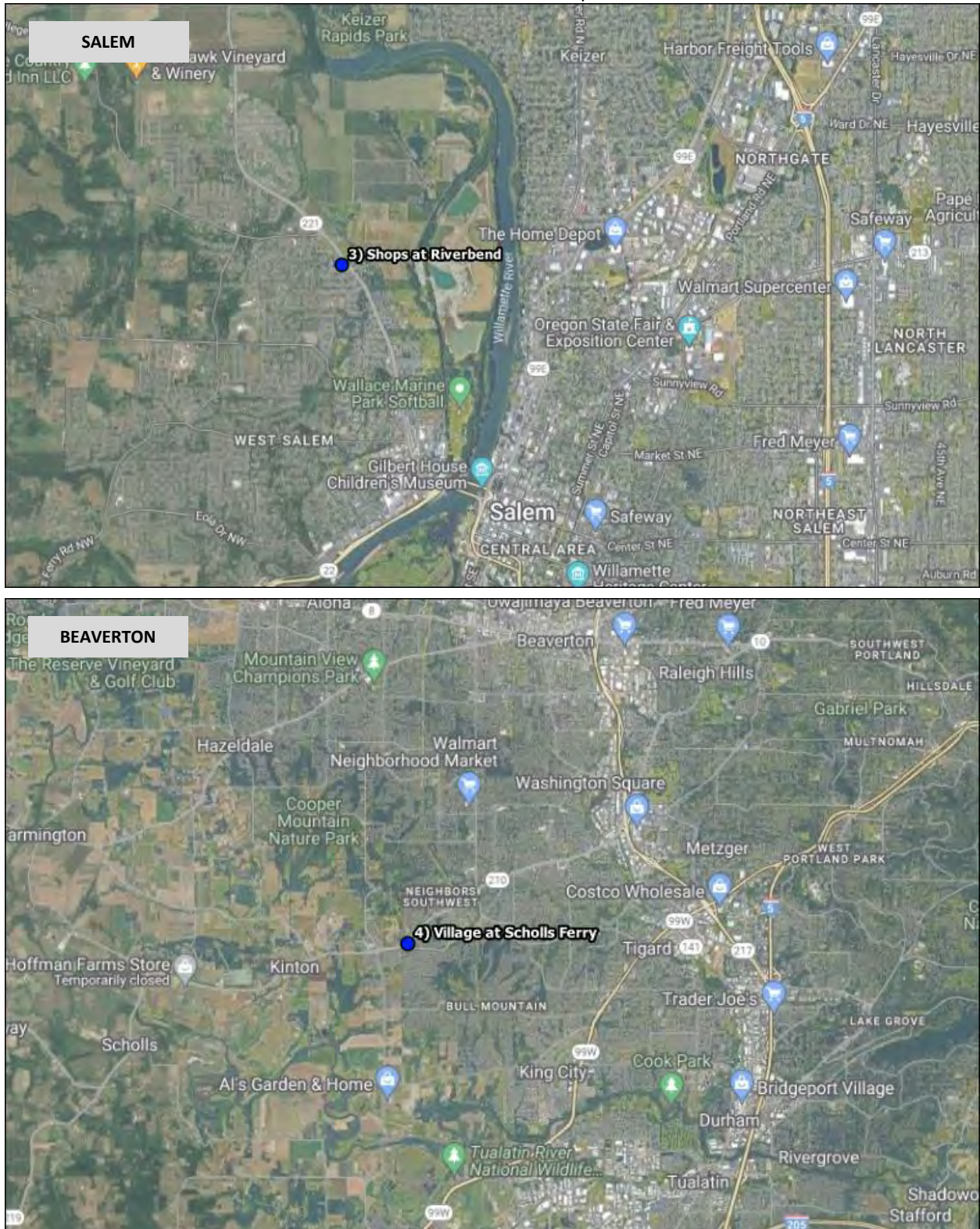

SOURCE: Google Earth, JOHNSON ECONOMICS



FIGURE 5.6: MAP OF SURVEYED RETAIL COMPARABLES, FELIDA (CLARK COUNTY, WA)

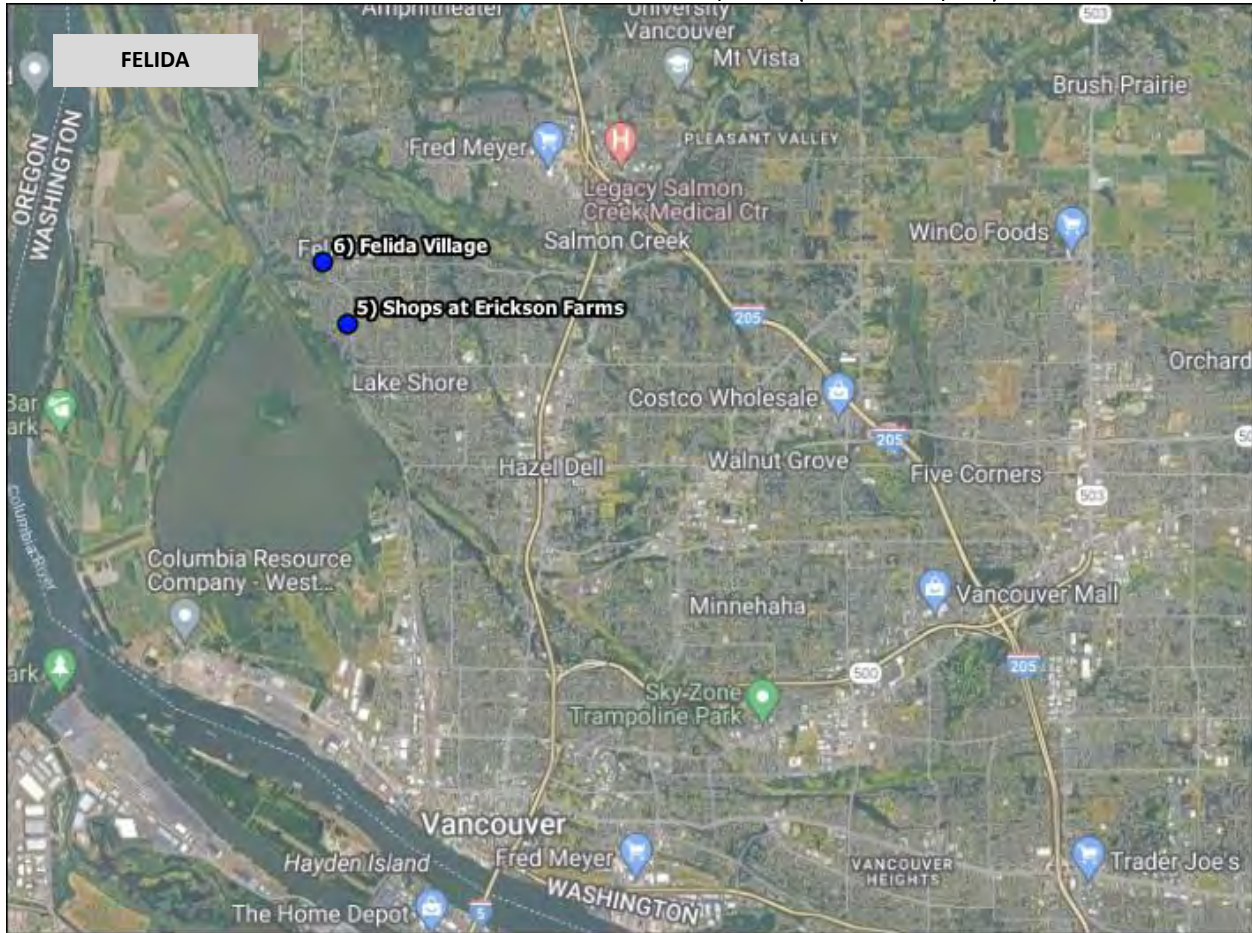

SOURCE: Google Earth, JOHNSON ECONOMICS

FIGURE 5.7: PROFILES OF SURVEYED RETAIL COMPARABLES

1) HILLSDALE PLAZA	
2274 SW 2nd St, McMinnville, OR	
Type:	Gabled suburban
Year built:	2009
Total RBA SF:	5,000
Parking/1,000 SF:	7.6
Street frontage 1:	SW 2nd St
Street frontage 2:	SW Hill Rd
Street 1 AADT:	8,200
Street 2 AADT:	3,200
Available SF:	0
Available %:	0%
Lease type:	MG
Asking lease rate:	\$18.00 (3Q22)
Current equiv. rate*:	\$18.00
2,447 SF leased in August 2022 at \$18 MG ask. Tenants: Valley Oasis Massage, Laughing Bean Bistro.	







2) VALLEY WELLNESS PLAZA

2191 NW 2nd St, McMinnville, OR

Type:	Medical Office
Year built:	1990
Total RBA SF:	13,900
Parking/1,000 SF:	7.5
Street frontage 1:	SW 2nd St
Street frontage 2:	SW Hill Rd
Street 1 AADT:	8,200
Street 2 AADT:	3,200
Available SF:	981
Available %:	7%
Lease type:	FS
Asking lease rate:	\$27.36
Current equiv. rate*:	\$27.36

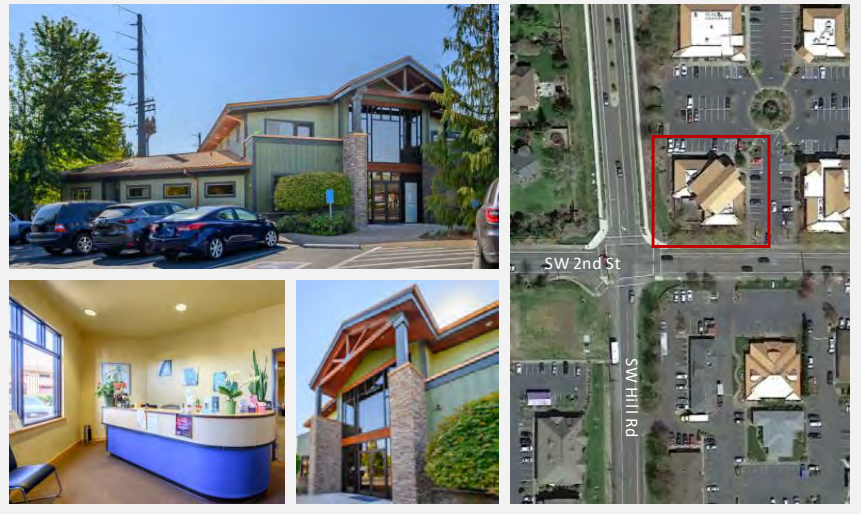
Notes: Tenants: Ability Physical Therapy, McMinnville Family Eye Care, Columbia Allergy, Providence Heart Clinic.



3) SHOPS AT RIVERBEND

1221 Riverbend Rd, Salem, OR

Type:	Strip mall
Year built:	2022
Total RBA SF:	10,780
Parking/1,000 SF:	7.3
Street frontage 1:	Wallace Rd NW
Street frontage 2:	Riverbend Rd
Street 1 AADT:	19,600
Street 2 AADT:	1,000
Available SF:	1,296
Available %:	12%
Lease type:	NNN
Asking lease rate:	\$25.00
Current equiv. rate*:	\$25.00

Notes: Strip mall with four 1,300-SF spaces and food cart pod with dining pavilion and spaces for 15 carts (all leased).



4) VILLAGE AT SCHOLLS FERRY

16315 SW Barrows Rd, Beaverton, OR

Type:	Neighborhood Ctr
Year built:	2008
Total RBA SF:	53,126
Parking/1,000 SF:	2.2
Street frontage 1:	SW Scholls Ferry Rd
Street frontage 2:	SW Barrows Rd
Street 1 AADT:	18,300
Street 2 AADT:	6,377
Available SF:	7,335
Available %:	14%
Lease type:	NNN
Asking lease rate:	\$28.00
Current equiv. rate*:	\$28.00

Notes: 3 bldgs (one 2-story on slope). Adjacent Dutch Bros. Tenants: Hillside Pub, Casa Lola Kitchen, Biscuits Café, Edward Jones, Inspired Life, Twist Spa ++





5) ERICKSON FARMS	
10722 NW Lakeshore Ave, Vancouver, WA	
Type:	Neighborhood Center
Year built:	2017-19
Total RBA SF:	34,376
Parking/1,000 SF:	5.1
Street frontage 1:	NW Lakeshore Ave
Street frontage 2:	NW 106th St
Street 1 AADT:	9,923
Street 2 AADT:	
Available SF:	0
Available %:	0%
Lease type:	NNN
Asking lease rate:	\$23.50
Current equiv. rate*:	\$23.50
Notes: Tenants: Los Potrillos, Mahoney Public House, Arktana, Creed Coffee, Nail Kitchen Spa, Windermere, Lakeshore Learning Center, Grapes & Growlers.	



6) FELIDA VILLAGE	
3600-04 NW 119th St, Vancouver, WA	
Type:	Neighborhood mixed-use
Year built:	2016
Total RBA SF:	10,600
Parking/1,000 SF:	3.8
Street frontage 1:	NW 36th Ave
Street frontage 2:	NW 119th St
Street 1 AADT:	11,100
Street 2 AADT:	4,500
Available SF:	0
Available %:	0%
Lease type:	NNN
Negotiated lease rate:	\$24.70
Current equiv. rate*:	\$24.70
Notes: Retail with office and apartments above. Office leased at \$20 in late 2021; retail at \$24 in 2020. Mt. Tabor Brewing, VX Vinos, Studio V, Barre3, Edward Jones.	



SOURCE: JOHNSON ECONOMICS

KEY OBSERVATIONS

The two comparables from McMinnville are located at the intersection of NW 2nd Street and SW Hill Road, as part of a commercial cluster at this intersection. The traffic volume at this intersection is in the low end of what can support new commercial development in today’s market. Estimates from ODOT (2021) indicate 8,200 daily trips on 2nd Street and 3,200 on Hill Road. The retail building at the southwest corner – Hillsdale Plaza, built in 2009 – most recently advertised an annual asking rate of \$18.00 modified gross per square foot (PSF) in late 2022. This likely represents a triple-net (NNN) rate below \$16.00 PSF, which is well below the typical threshold for supporting new construction. However, the building has a basic profile without strong tenant visibility or signage potential due to its gabled roof and low ceiling height. A modern retail building would likely capture higher rents.

The medical office building at the northeast corner of the 2nd/Hill intersection – Yamhill Valley Wellness Plaza – is older (1990) but built to a higher standard. It currently has a small suite available at a \$27.36 full-service asking rate. Converted to triple-net terms, this may reflect a rate in the low \$20s. Again, more modern space would likely capture somewhat higher rates.



To our knowledge, the best example of a recent commercial development with a neighborhood orientation on a site with similar traffic exposure is the Shops at Erickson Farms in Felida, north of Vancouver, Washington. Felida is one of the most affluent suburban areas in Clark County. The project sits along Lakeshore Avenue, centrally within a large residential area that was without commercial amenities prior to its opening in 2017. The nearest commercial options are in the I-5 corridor, two-three miles to the east. In comparison, Hill Road is roughly two miles from Highway 99. The current daily traffic volume on Lakeshore Avenue is 9,900, which means that the project has one of the lowest traffic volumes among newer retail centers in the suburban parts of the Portland-Salem area. The relatively low lease rates, \$23.50, are reflective of the limited traffic exposure. The rates have remained at this level since opening. The property totals 34,000 square feet (fully leased), including office/daycare buildings. Most tenants are food/beverage and service establishments. Felida’s relatively affluent household base has contributed to the support for the project.

Felida Village is a mixed-use project located along the same road, with slightly higher traffic volumes (11,100 AADT). It was built in 2016 and includes 10,600 square feet of commercial space (mostly ground-floor retail) plus eight apartments on the second floor. While most mixed-use projects are built in more urban areas, near transit centers, or along roads with more pedestrian/bike traffic, this project is a unique example of a mixed-use project along a suburban arterial road with moderate traffic. Current lease rates average \$24.70 NNN for ground-floor space and \$19.25 for second-floor office space. Tenants include a brewpub and service providers. As with Erickson Farms, the relatively affluent household base in Felida and the distance to larger commercial centers have helped the project.

The Village at Scholls Ferry in Beaverton is a larger project, totaling 53,000 square feet. It also has a neighborhood orientation, but benefits from higher traffic exposure (18,000 AADT). However, at the time it was built in 2008, it was at the western periphery of Beaverton, with farmland to the west. Traffic volumes on Scholls Ferry Road were likely much lower than today. It leased up at rates in the \$26-32 range. The current asking rate is \$28.00, with 7,000 square feet vacant. Tenants are mainly food/beverage and service providers.

The Shops at Riverbend is a smaller project with one retail building (5,200 SF) for four smaller tenants plus a food cart pod and a dining pavilion. It is located along Wallace Road in West Salem, with average daily traffic of roughly 20,000. The asking rate for the retail space is \$25.00 NNN, with only one space left. Current tenants include a nail salon and flower shop, plus the food carts.

FIGURE 5.8: SUMMARY OF SURVEYED RETAIL PROPERTIES

PROPERTY	ADDRESS	TRAFFIC	YEAR	TOTAL	AVAIL.	LEASE RATE		
		AADT	BUILT			FLOORS	RETAIL SF	(%)
1) Hillsdale Plaza	2274 SW 2nd St, McMinnville, OR	8,200	2009	1	5,000	0%	\$18.00	MG
2) Valley Wellness Center	2191 NW 2nd St, McMinnville, OR	8,200	1990	1	13,900	7%	\$27.36	FS
3) Shops at Riverbend	1221 Riverbend Rd, Salem, OR	13,300	2021+	1	46,100	0%	\$25.00	NNN
4) Village at Scholls Ferry	16315 SW Barrows Rd, Beaverton, OR	18,300	2008	2	53,126	14%	\$28.00	NNN
5) Shops at Erickson Farms	10722 NW Lakeshore Ave, Vancouver, WA	9,900	2017-19	1	34,376	0%	\$23.50	NNN
6) Felida Village	3600-04 NW 119th St, Vancouver, WA	11,100	2016	1	10,600	0%	\$24.70	NNN

SOURCE: Brokers; developers; online media; CoStar; JOHNSON ECONOMICS

HOUSEHOLD SUPPORT

Support for commercial establishments in the Neighborhood Activity Center (NAC) will come from the surrounding household base, both within and outside the Fox Ridge area. In order to evaluate this support, we estimate the sales generated by the surrounding households, today and in the future. We also evaluate current and future traffic flows past the site, before we in the next section estimate the amount of commercial space that is feasible within the NAC.

NEIGHBORHOOD TRADE AREA

The first step in this analysis is to delineate the geographic area from which the NAC is likely to capture household spending. For this determination, we assume that each household in the surrounding area will use the nearest



commercial center, as measured in drive time (Google Maps). Though households in reality conduct their shopping at multiple locations, we assume that the nearest commercial center has the advantage in capturing shopping traffic from the household if the type of retail or service is provided at this location. The delineated trade area for the NAC represents the drive-time mid-points between the NAC and other commercial centers. And though households within this trade area will do much of their shopping outside this area, establishments within the NAC will also attract customers from outside the area. We assume that the trade area boundary represents the points where these in- and outflows of demand offset each other. We refer to this trade area as the Core Trade Area (CTA).

In the delineation of the CTA, we take into account both existing and planned commercial centers. The existing commercial cluster around 2nd Street and Hill Road limits the trade area to the south, while the planned commercial center on Baker Creek Road and Hill Road limits the trade area to the north. The nearest alternatives to the east are in the Highway 99 corridor. For each center or commercial area, we use the nearest main intersection when estimating drive times (Wallace Rd/Hill Rd for the NAC). The resulting trade area delineation for the NAC is shown below.

FIGURE 5.9: NAC COMMERCIAL CORE TRADE AREA (CTA)



SOURCE: Google Earth, Metro, JOHNSON ECONOMICS



SUPPORT FOR COMMERCIAL ACTIVITIES

A geographic analysis of assessor data indicates that there are 915 housing units within the CTA currently. In the following, we present estimates of supported employment and spending in retail and service categories that typically take place in commercial buildings, based on averages from suburban and rural parts of Oregon and Washington states. We also provide estimates for future support, assuming the increase of 567 housing units in the Fox Ridge area. This assumption is based on the preceding residential analysis and includes 150 rental apartments, 30 townhomes, and 387 detached single-family homes (80 acres with 9,000-square-foot lots). At that point, the housing inventory in the CTA will have grown to almost 1,500.

Employment and sales estimates are converted to square footage based on typical/average ratios observed in various surveys and studies conducted by Johnson Economics. These include employment density surveys, surveys published in trade publications, and analyses of financial reports from retailers. Per-square-foot spending estimates are updated annually to account for inflation. Note that there is significant variation in space utilization between different types of establishments within each category.

The estimates of current and future commercial support are presented over the next two pages. Categories in grey font are retail/service formats that would either be inconsistent with the type of neighborhood center envisioned in the NAC or that require a mall or downtown location in the current retail market.

In most categories, the support estimated to be generated by the households within the CTA represents less than one average-size establishment. Based on the current household count, only two categories exhibit support for at least one establishment: full- and limited-service restaurants. Each is estimated to have support for roughly two establishments. This means that restaurant spending by the households currently living in the CTA should total the average sales of around four restaurants. However, it does not mean that there is market support for four restaurants in the NAC currently. Neighborhood centers can only capture a portion of the restaurant spending by surrounding households, as some restaurant spending takes place in conjunction with shopping at larger centers or as part of travel or destination visits to downtown restaurants. A qualitative evaluation is required to estimate the amount of household spending that can be captured in the NAC. The same is true for the other categories as well. Based on the current-year sales estimates, we believe there is inadequate support for new construction commercial space in the NAC currently.

In the estimates of future support, the model indicates that five additional categories will have CTA support equivalent to at least one average-size establishment. These are all service categories, representing medical, professional, and personal service providers. These indicate potential for a small commercial center in the NAC. In the following, we will evaluate which of these are likely to capture adequate demand with a NAC location.



FIGURE 5.10: CURRENT SUPPORT FOR COMMERCIAL ACTIVITIES, NAC CTA (2023)

CURRENT COMMERCIAL POTENTIAL		MARKET SUPPORT			
Category	Major Category	Establish-ments	Employ-ment	An. Sales (\$1,000)	Square Feet
Physician/clinic	Health services	1.0	18	\$3,127	12,387
Grocery	Everyday goods	0.3	19	\$6,584	11,351
Hardware/materials/garden	Home/garden	0.4	7	\$2,057	10,203
FS restaurant	Eating/drinking places	2.0	37	\$2,468	5,494
Fitness	Fitness/dance/martial arts	0.4	7	\$387	5,241
LS restaurant	Eating/drinking places	1.8	30	\$2,241	4,021
Bank	Bank	0.4	8	\$1,095	2,208
Chiropractor/physical therapy	Health services	0.8	6	\$609	2,082
Dentist	Health services	0.9	7	\$1,103	1,987
Pet supplies	Hobby/leisure/pets	0.1	1	\$255	1,706
Hair/nail/spa	Personal care	0.8	4	\$233	1,492
Used goods	Used goods	0.2	4	\$342	1,466
Insurance	Financial/legal/insurance	0.7	5	\$835	1,234
Bar/pub	Eating/drinking places	0.3	3	\$277	980
Convenience	Everyday goods	0.4	2	\$677	966
Pet care/grooming	Personal care	0.2	1	\$56	953
Coffee/juice/ice cream	Eating/drinking places	0.6	7	\$442	753
Wireless	Wireless	0.4	6	\$2,438	705
Gas station	Gas station	0.4	4	\$3,873	699
Specialty foods/drinks	Everyday goods	0.4	3	\$534	670
Vet/animal clinic	Health services	0.3	4	\$573	662
Attorney	Financial/legal/insurance	0.3	2	\$481	579
Optic/vision	Health services	0.2	1	\$153	550
Martial arts	Fitness/dance/martial arts	0.1	1	\$81	442
Brewery/winery/distillery	Eating/drinking places	0.1	1	\$50	414
CPA	Financial/legal/insurance	0.3	2	\$202	389
Mortgage/title	Financial/legal/insurance	0.2	2	\$491	344
Tanning	Personal care	0.1	1	\$61	300
Delivery/mailbox	Other service	0.1	1	\$124	287
Financial advisor/broker	Financial/legal/insurance	0.3	2	\$448	282
Drycleaning/laundry/alterations	Other service	0.2	1	\$107	195
Dance/aerobic/yoga/music	Fitness/dance/martial arts	0.1	1	\$49	185
Flowers	Home/garden	0.1	0	\$34	156
Health/supplements	Everyday goods	0.1	0	\$64	98
Supercenter/warehouse club	Everyday goods	0.1	16	\$7,472	8,181
Discount department store	Everyday goods	0.1	5	\$1,041	7,627
Furniture/home goods	Home/garden	0.3	3	\$903	6,683
Auto service/carwash	Auto service/care	0.8	6	\$961	3,738
Sporting goods	Hobby/leisure/pets	0.2	2	\$372	3,714
Pharmacy	Everyday goods	0.2	3	\$1,162	2,902
Auto parts	Auto parts	0.4	4	\$1,068	2,571
Motor vehicle dealer	Motor vehicle dealer	0.3	9	\$7,636	2,399
Hobby/games/toys	Hobby/leisure/pets	0.2	2	\$204	1,710
Discount store	Everyday goods	0.1	2	\$206	1,622
Movie theater	Entertainment	0.0	1	\$132	1,198
Clothing	Clothing/accessories/cosmetics	0.2	3	\$456	1,006
Office supplies	Office/electronics/appliances	0.0	1	\$138	871
Department store	Clothing/accessories/cosmetics	0.0	1	\$34	844
Discount clothing/home store	Clothing/accessories/cosmetics	0.0	1	\$363	835
Electronics/appliances	Office/electronics/appliances	0.0	0	\$191	797
Real estate agent	Financial/legal/insurance	0.3	1	\$692	408
Shoes	Clothing/accessories/cosmetics	0.1	1	\$191	389
Music	Hobby/leisure/pets	0.0	0	\$63	276
Gifts	Hobby/leisure/pets	0.1	1	\$93	275
Other	Other service	0.2	1	\$86	258
Cosmetics	Clothing/accessories/cosmetics	0.0	1	\$88	172
Books	Hobby/leisure/pets	0.0	0	\$65	153
Photography	Other service	0.0	0	\$19	132
Jewelry	Clothing/accessories/cosmetics	0.1	0	\$111	115
Travel	Other service	0.1	0	\$38	111
Printing	Other service	0.0	1	\$85	107
Other entertainment	Entertainment	0.0	0	\$10	30
Payday Loans	Financial/legal/insurance	0.0	0	\$69	18
Total		19	268	\$56,498	120,620

SOURCE: U.S. Commerce Department, U.S. Census Bureau, U.S. BLS, JOHNSON ECONOMICS



FIGURE 5.11: FUTURE SUPPORT FOR COMMERCIAL ACTIVITIES, NAC CTA (+567 HOUSEHOLDS)

FUTURE COMMERCIAL POTENTIAL, +567 HOUSEHOLDS		MARKET SUPPORT			
Category	Major Category	Establish-ments	Employ-ment	Sales (\$1,000)	Square Feet
Physician/clinic	Health services	1.6	30	\$5,084	20,138
Grocery	Everyday goods	0.5	31	\$10,704	18,455
Hardware/materials/garden	Home/garden	0.6	11	\$3,345	16,588
FS restaurant	Eating/drinking places	3.2	60	\$4,013	8,933
Fitness	Fitness/dance/martial arts	0.6	12	\$629	8,521
LS restaurant	Eating/drinking places	3.0	49	\$3,644	6,537
Bank	Bank	0.7	13	\$1,780	3,590
Chiropractor/physical therapy	Health services	1.4	10	\$991	3,386
Dentist	Health services	1.5	12	\$1,793	3,231
Pet supplies	Hobby/leisure/pets	0.2	2	\$415	2,774
Hair/nail/spa	Personal care	1.3	6	\$379	2,425
Used goods	Used goods	0.3	7	\$556	2,383
Insurance	Financial/legal/insurance	1.1	9	\$1,357	2,007
Bar/pub	Eating/drinking places	0.5	5	\$450	1,593
Convenience	Everyday goods	0.7	4	\$1,100	1,570
Pet care/grooming	Personal care	0.3	2	\$91	1,549
Coffee/juice/ice cream	Eating/drinking places	1.0	11	\$719	1,224
Wireless	Wireless	0.6	10	\$3,964	1,146
Gas station	Gas station	0.6	7	\$6,296	1,136
Specialty foods/drinks	Everyday goods	0.7	6	\$868	1,089
Vet/animal clinic	Health services	0.5	7	\$931	1,076
Attorney	Financial/legal/insurance	0.5	3	\$782	942
Optic/vision	Health services	0.3	2	\$248	895
Martial arts	Fitness/dance/martial arts	0.2	2	\$132	719
Brewery/winery/distillery	Eating/drinking places	0.1	1	\$81	673
CPA	Financial/legal/insurance	0.5	4	\$329	632
Mortgage/title	Financial/legal/insurance	0.3	3	\$798	560
Tanning	Personal care	0.2	2	\$99	487
Financial advisor/broker	Financial/legal/insurance	0.5	3	\$728	459
Drycleaning/laundry/alterations	Other service	0.3	1	\$173	317
Dance/aerobic/yoga/music	Fitness/dance/martial arts	0.2	2	\$80	301
Flowers	Home/garden	0.1	0	\$55	254
Health/supplements	Everyday goods	0.1	1	\$104	159
Delivery/mailbox	Other service	0.0	1	\$201	82
Supercenter/warehouse club	Everyday goods	0.1	27	\$12,148	13,301
Discount department store	Everyday goods	0.1	7	\$1,693	12,401
Furniture/home goods	Home/garden	0.5	5	\$1,469	10,865
Auto service/carwash	Auto service/care	1.3	9	\$1,562	6,077
Sporting goods	Hobby/leisure/pets	0.3	3	\$605	6,038
Pharmacy	Everyday goods	0.3	5	\$1,889	4,718
Auto parts	Auto parts	0.7	7	\$1,736	4,180
Motor vehicle dealer	Motor vehicle dealer	0.5	15	\$12,415	3,900
Hobby/games/toys	Hobby/leisure/pets	0.3	3	\$332	2,781
Discount store	Everyday goods	0.2	3	\$335	2,637
Movie theater	Entertainment	0.0	1	\$214	1,947
Clothing	Clothing/accessories/cosmetics	0.3	5	\$741	1,635
Office supplies	Office/electronics/appliances	0.1	1	\$224	1,416
Department store	Clothing/accessories/cosmetics	0.0	1	\$55	1,371
Discount clothing/home store	Clothing/accessories/cosmetics	0.0	2	\$591	1,357
Electronics/appliances	Office/electronics/appliances	0.1	1	\$311	1,295
Real estate agent	Financial/legal/insurance	0.5	2	\$1,124	663
Shoes	Clothing/accessories/cosmetics	0.1	2	\$311	633
Music	Hobby/leisure/pets	0.1	1	\$102	449
Gifts	Hobby/leisure/pets	0.2	1	\$151	448
Other	Other service	0.3	2	\$140	419
Cosmetics	Clothing/accessories/cosmetics	0.1	1	\$143	280
Books	Hobby/leisure/pets	0.0	1	\$105	249
Photography	Other service	0.1	0	\$31	214
Jewelry	Clothing/accessories/cosmetics	0.1	1	\$181	186
Travel	Other service	0.1	1	\$61	180
Printing	Other service	0.1	1	\$138	174
Other entertainment	Entertainment	0.0	0	\$16	48
Payday Loans	Financial/legal/insurance	0.0	0	\$113	30
Total		31	435	\$91,857	195,724

SOURCE: U.S. Commerce Department, U.S. Census Bureau, U.S. BLS, JOHNSON ECONOMICS



TRAFFIC VOLUMES

Traffic flows also have some bearing on the ability of a site to capture commercial demand. We therefore include a brief analysis of current and future traffic flows past the site. Based on our surveys of retail centers built over the past 10 years, we find that most auto-oriented suburban centers require daily traffic volumes of 10,000-15,000 before sales levels can sustain lease rates that can support the cost of new construction. However, projects that function as neighborhood or village centers in underserved residential areas or with good pedestrian access can find adequate support at lower traffic levels (e.g., Forest Heights Village, Portland; Crescent Village, Eugene; Avimor, Boise; Issaquah Highlands, Issaquah).

The most recent traffic counts on Hill Road are from just south of SW Tamarack Road, where the 2021 ODOT count was 3,200 AADT. The closest recent count on Wallace Road was 2,800 AADT just west of Cypress Road, also from 2021. We will assume that these counts reflect the current traffic level at the Hill/Wallace intersection. These traffic counts would in most cases be inadequate for auto-oriented commercial users.

Development of the Fox Ridge area will generate additional traffic past the site. Trip generation varies with housing format. Based on the preceding residential analysis, we will assume that the Neighborhood Activity Center (NAC) will include 150 multifamily units and 30 attached single-family units (15 rental; 15 ownership). Based on typical trip generation rates, these will increase the traffic volume by around 1,250 daily trips. For the remaining residential portion of the Fox Ridge area, we will assume that 80 acres will be developed over a 10-year period, creating 387 detached units (9,000-SF lots). These will generate an estimated 3,700 trips. Not taking into account other development in the city, the daily trip count on Hill Road should then be around 8,000. A new high school within the Fox Ridge area would add to this count. Other development on the westside will further increase the traffic volume.

FIGURE 5.12: ESTIMATED DAILY TRIPS PAST THE SUBJECT SITE, GENERATED BY FUTURE HOUSING

	HOUSING UNITS				TRIPS			
	SFD	SFA	MF	Total	SFD	SFA	MF	Total
					9.5/u.	8.1/u.	6.7/u.	
Existing								3,200
Fox Ridge NAC	0	30	150	180	0	243	1,005	1,248
Fox Ridge Low-Density	387	0	0	387	3,678	0	0	3,678
Total	387	30	150	567	3,678	243	1,005	8,126

SOURCE: Institute of Traffic Engineers, City of McMinnville, JOHNSON ECONOMICS

As mentioned, the current traffic volume on Hill Road would in most cases be inadequate to support auto-oriented commercial activity. However, a daily traffic volume around 8,000, plus additional high-school traffic, is likely adequate for a small neighborhood center that can rely on pedestrian/resident traffic as well as pass-by arterial traffic. Tenants are most likely to be independent establishments or local chain. National chains typically seek locations with higher traffic volumes.

ABSORPTION

As indicated, the NAC will only be able to capture a portion of the commercial demand generated within the CTA. Residents in this area will continue to visit major shopping centers outside the CTA, and they will continue to combine shopping with other activities outside the CTA. However, with anticipated household count and traffic volumes, we regard it likely that some establishments will find adequate support in the NAC. Food/beverage and service providers are the most likely tenants. We expect 5,000-10,000 square feet to be feasible, assuming a location by the Hill/Wallace intersection with good access from Hill Road as well as residential portions of Fox Ridge. We would plan for spaces in the range of 1,000-3,000 square feet (see next page), with a strip mall the most likely format.



We also expect potential for a daycare in a separate building within the NAC, given the increase in number of families in this area as Fox Ridge is built out. In total, this indicates potential for a commercial area of roughly 1.0 acre. We would assume that at least 400 residential units will have to be completed within the Fox Ridge area before a commercial center of this size becomes feasible.

FIGURE 5.13: POTENTIAL TENANTS AND ACHIEVABLE PRICING (1Q23)*, SUBJECT SITE

#	MAJOR CATEGORY	CATEGORY	SQ.FT.	FAR	ACRES	RATE LOW	RATE HIGH
1	Eating/drinking places	Restaurant	2,800	0.25	0.3	\$25.00	\$27.00
2	Eating/drinking places	Restaurant/coffee	1,500	0.25	0.1	\$25.00	\$27.00
3	Personal care	Hair/nail/spa salon	1,500	0.25	0.1	\$24.00	\$26.00
4	Health/medical services	Physician/chiropractor	1,500	0.35	0.1	\$24.00	\$26.00
5	Professional/financial services	Real estate/insurance	1,000	0.35	0.1	\$24.00	\$26.00
6	Education	Daycare/preschool	4,000	0.30	0.3	\$22.00	\$24.00
Total:			12,300		1.0	\$22.00	\$27.00

* Achievable lease rates are annual NNN rates per square foot.

SOURCE: JOHNSON ECONOMICS

Additionally, there may also be potential for a gas station with a convenience store within the NAC. Though the CTA households alone may provide inadequate support, the lack of a gas station west of Highway 99 suggests potential for a gas/convenience option along Hill Road. This may absorb another acre of land. We are aware of other neighborhood gas/convenience projects currently in development on sites with traffic volumes comparable to the estimated future traffic count on Hill Road (e.g., Camas Station at the northwest corner of NW 16th Avenue and Brady Road in Camas, 7,600 + 6,100 AADT).

ACHIEVABLE PRICING

The above estimates of absorption potential include the inherent assumption of ability to pay lease rates that can justify new construction. However, based on our survey of comparables and our estimates of market support, we would expect the achievable lease rates to be in the low end of what can support new construction, requiring cost-effective design and building formats. Based on current market rates, we would assume rates in the \$24-27 range for ground-floor commercial space (NNN), with somewhat lower rates for a daycare building, as shown in the table above. These rates can be expected to increase with the market prior to market introduction.



VI. CONCLUSIONS

FEASIBLE USES

The preceding analysis indicates adequate market support for rental apartments, rental townhomes, ownership townhomes, and commercial space in the Fox Ridge Neighborhood Activity Center (NAC). In the current market, we would expect a single-phase 200-unit apartment project to be feasible with a 12-month absorption horizon, given the current apartment shortage and limited development pipeline in McMinnville. For a more long-term assumption, we regard a 150-unit apartment project plus 15 rental townhomes and 15 ownership townhomes to be feasible within a one-year absorption period. We expect a project of this scale to require roughly eight acres of land.

Following additional residential buildout of the Fox Ridge area, we expect a small commercial center of 5,000-10,000 square feet, plus a separate daycare center, to be feasible within the NAC. We expect these uses to absorb around one acre of land. A gas station with a convenience store may also become feasible, absorbing another acre or so.

In total, this indicates potential for a Neighborhood Activity Center that spans 9-10 acres. With a multi-phase approach to the residential components, with absorption over a three- to four-year period, we would expect that the scale of the residential development could be doubled, increasing the size of the NAC to 17-18 acres.

FIGURE 6.1: POTENTIAL LAND ABSORPTION

FEASIBLE USES			Res. Density	Com.	Land Need
LAND USE	Scale	Unit	(U/Ac)	FAR	(Acres)
Rental apartments	150	Units	28		5.4
Rental townhomes	15	Units	14		1.1
Ownership townhomes	15	Units	10		1.5
Retail space	8,300	SF		0.27	0.7
Daycare center	4,000	SF		0.30	0.3
Gas station w/conv. store	5,000	SF		0.15	0.8
Total					8.9 (9.7)

SOURCE: JOHNSON ECONOMICS

FEASIBLE BUILDING FORMATS

RENTAL APARTMENTS

Current market rents indicate that rental apartments within the NAC are most likely to be three-story walk-up structures with surface parking. Higher rent levels would likely be needed to support taller and more costly formats like elevator buildings and tuck-under or podium parking.





RENTAL TOWNHOMES

We expect rental townhomes both with and without attached garages to be feasible in the NAC, most likely two stories tall. The achievable rent estimates provided for rental townhomes earlier in the report assume surface parking. Attached garages would likely generate additional rent premiums (\$100-150/mo.).



OWNERSHIP TOWNHOMES

We also expect ownership townhomes to be feasible. These typically represent a somewhat higher standard in terms of design and finishes than rental townhomes, and typically include attached garages. Two-story homes are most common, but three-story structures might also be feasible.



COMMERCIAL SPACE

At the estimated achievable lease rates, a multi-tenant strip mall is the most likely commercial format in the NAC. Freestanding single-tenant buildings generally represent higher construction costs, but may be viable with cost-effective features (e.g., gable roof, smaller windows). One possible exception is a gas/convenience project, which is likely to a standard gas station format. The most likely format for a daycare is a gable-roof, single-story structure.





MIXED-USE POTENTIAL

Vertical mixed-use projects with residential units above ground-floor commercial space are best suited for urban locations with significant bike and pedestrian traffic. In locations where the commercial tenants are dependent on auto traffic, the mixed-use format can be difficult to combine with the needs for visibility, signage, and parking convenience. These buildings usually do not offer the kind of signage surround that makes a logo stand out, while the upper floors tend to distract from the signage, especially if they include balconies. Moreover, suburban commercial tenants generally need convenient parking in front of the stores in order to maximize the capture of auto traffic. They also need clearly separated residential and commercial parking. Certain uses, like restaurants, may also require additional accommodation (e.g., soundproofing, ventilation) in order to limit nuisance for residents. Due to the cost and rent impacts of these factors, we do not expect vertical mixed-use projects to be feasible in the NAC. However, as shown by Felida Village in the previous section, low-cost versions of this format may be possible, though Felida Village has been helped by a relatively affluent surrounding household base.

LOCATION OF USES

Commercial activity in the NAC will depend on good exposure to auto traffic, and will therefore need a location near one of the major Hill Road intersections, either at Wallace Road or Fox Ridge Road. Assuming future development of the high school site, the Wallace Road intersection will likely provide the strongest exposure, positioning the commercial component to capture demand from residents east of Hill Road in addition to Fox Ridge residents. This will require a site and road layout that provides easy access between Fox Ridge Road and the commercial center.

Both rental apartments and townhomes function well adjacent to commercial uses from a market standpoint. However, rental housing tends to benefit more from this proximity, as renters tend to value access higher than homeowners. The latter, who typically include a large share of families, tend to place greater emphasis on safety, and will often prefer separation from commercial traffic. We therefore recommend rental apartments closest to the commercial section.

APPENDIX F

FOX RIDGE ROAD AREA PLAN

TRANSPORTATION ANALYSIS: EXISTING AND FUTURE CONDITIONS

NOVEMBER 2023



PREPARED FOR THE CITY OF MCMINNVILLE



Tom Schauer, AICP, Senior Planner

Heather Richards, Community Development Director

PREPARED BY DKS ASSOCIATES



Scott Mansur, PE, PTOE, RSP₁

Jenna Bogert, PE



TABLE OF CONTENTS

- EXECUTIVE SUMMARY 1**

- EXISTING TRAFFIC CONDITIONS (2023) 2**
 - EXISTING TRAFFIC VOLUMES..... 2
 - INTERSECTION PERFORMANCE MEASURES..... 2
 - EXISTING INTERSECTION OPERATIONS 3
 - BICYCLE, PEDESTRIAN, AND TRANSIT NEEDS 5
 - PRIORITY TSP PROJECTS 5

- FUTURE BASELINE CONDITIONS (2041) 6**
 - FUTURE BASELINE TRAFFIC VOLUMES..... 6
 - FUTURE BASELINE INTERSECTION OPERATIONS 8

- PREFERRED LAND USE SCENARIO CONDITIONS (2041) 9**
 - PREFERRED LAND USE ASSUMPTIONS 9
 - PREFERRED LAND USE SCENARIO TRAFFIC VOLUMES 11
 - PREFERRED LAND USE SCENARIO INTERSECTION OPERATIONS 13
 - PRIORITY TSP PROJECTS 14
 - RECOMMENDED TRANSPORTATION IMPROVEMENTS 14

- SUMMARY & RECOMMENDATION 16**

- APPENDIX 17**

LIST OF FIGURES

FIGURE 1: EXISTING 2023 TRAFFIC VOLUMES, LANE GEOMETRIES, AND TRAFFIC CONTROL	4
FIGURE 2: BASELINE (2041) TRAFFIC VOLUMES, LANE GEOMETRIES, AND TRAFFIC CONTROL	7
FIGURE 3: PREFERRED LAND USE (2041) TRAFFIC VOLUMES, LANE GEOMETRIES, AND TRAFFIC CONTROL	12

LIST OF TABLES

TABLE 1: EXISTING (2023) INTERSECTION OPERATIONS	5
TABLE 2: FUTURE BASELINE (2041) INTERSECTION OPERATIONS	8
TABLE 3: LAND USE ASSUMPTIONS	9
TABLE 4: VEHICLE TRIP GENERATION	10
TABLE 5: PREFERRED LAND USE SCENARIO (2041) INTERSECTION OPERATIONS	13
TABLE 6: PREFERRED LAND USE SCENARIO (2041) INTERSECTION OPERATIONS – WITH IMPROVEMENTS	15

This report documents the traffic analysis performed in association with the Fox Ridge Road Area Plan in McMinnville, Oregon. The purpose of this traffic analysis is to help identify and inform transportation issues that would need to be addressed in the City's Transportation System Plan update.

An executive summary of this transportation analysis is provided below. The following sections of this memorandum document the existing traffic conditions (2023), future baseline and preferred land use traffic conditions (2041), and a list of resulting transportation projects needed to support the build out of the Fox Ridge Road plan area.

EXECUTIVE SUMMARY

To determine existing and future transportation conditions for the Fox Ridge area, a comprehensive traffic analysis was performed. The analysis focused on five key intersections along NW Hill Road.

Fox Ridge Road Plan Area

The Fox Ridge Road Plan Area includes 200+ acres of land that currently contains rural, low density lands and publicly owned lands. The future development of the Plan Area primarily includes a mix of residential housing (low-, medium-, and high-density), parks and open spaces, some neighborhood mixed-use commercial, and 42 acres that are owned by the school district.¹

Analysis Findings & Recommended Improvement Projects

Intersection traffic operations were analyzed for the weekday AM and PM peak hours under the existing 2023 conditions and future 2041 conditions to evaluate if the study intersections meet the City's desired performance levels under the Preferred Land Use scenario.

Currently, the five study intersections all meet the City's performance standard.

In the Preferred Land Use 2041 scenario, all but two of the study intersections are expected to continue to meet standards and targets in the future. The suggested improvements are listed below.

- **NW Hill Road at Fox Ridge Road:** Install a single-lane roundabout or traffic signal. This project is not listed in the City's current TSP (2010).
- **NW Hill Road at 2nd Street:** Install a single-lane roundabout or traffic signal. This is consistent with the priority project identified in the City's current TSP (2010).

¹ The property owned by the school district is already located within the City limits and is planned to be developed into a high school.

EXISTING TRAFFIC CONDITIONS (2023)

Existing traffic conditions were evaluated for the study area and include traffic volumes; intersection operations; and bike, pedestrian, and transit needs.

EXISTING TRAFFIC VOLUMES

Traffic counts were collected for the AM peak period (7:00 to 9:00 a.m.) and PM peak period (4:00 to 6:00 p.m.) at the following study intersections.³ The AM and PM peak hour traffic volumes (i.e., the highest hourly volumes during the peak period) are shown in Figure 1 and the traffic counts are provided in the appendix.

- NW Hill Road & Baker Creek Road
- NW Hill Road & Wallace Road
- NW Hill Road & Fox Ridge Road
- NW Hill Road & 2nd Street
- NW Hill Road & Fellows Street

INTERSECTION PERFORMANCE MEASURES

Agency mobility standards often require intersections to meet level of service (LOS) or volume-to-capacity (v/c) intersection operation thresholds. Additional operational details are provided in the appendix.

- The intersection LOS is similar to a “report card” rating based upon average vehicle delay. Level of service A, B, and C indicate conditions where traffic moves without significant delays over periods of peak hour travel demand. Level of service D and E are progressively worse operating conditions. Level of service F represents conditions where average vehicle delay has become excessive and demand has exceeded capacity. This condition is typically evident in long queues and delays.
- The volume-to-capacity (v/c) ratio represents the level of saturation of the intersection or individual movement. It is determined by dividing the peak hour traffic volume by the maximum hourly capacity of an intersection or turn movement. When the V/C ratio approaches 0.95, operations become unstable and small disruptions can cause the traffic flow to break down, resulting in the formation of excessive queues.

The City of McMinnville requires all city intersections to meet the mobility standard, which is a v/c ratio of 0.90 or less.⁴

³ The counts were collected on June 1, 2023.

⁴ Table 2-2, McMinnville Transportation System Plan, 2010.

EXISTING INTERSECTION OPERATIONS

Intersection operations were analyzed for the PM peak hour to evaluate whether the transportation network currently operates within desired performance levels as required by the City of McMinnville. Intersections are the focus of the analysis because they are the controlling bottlenecks of traffic flow and the ability of a roadway system to carry traffic efficiently is nearly always diminished in their vicinity. The existing AM and PM peak hour intersection operations at the study intersection were determined based on the 6th Edition Highway Capacity Manual methodology.⁵ Table 1 lists the estimated average delay (in seconds), level of service (LOS), and volume to capacity (v/c) ratio for each study intersection. As shown, all intersections currently meet the City's mobility standard.

⁵ Highway Capacity Manual, 6th Edition, Transportation Research Board, 2017.

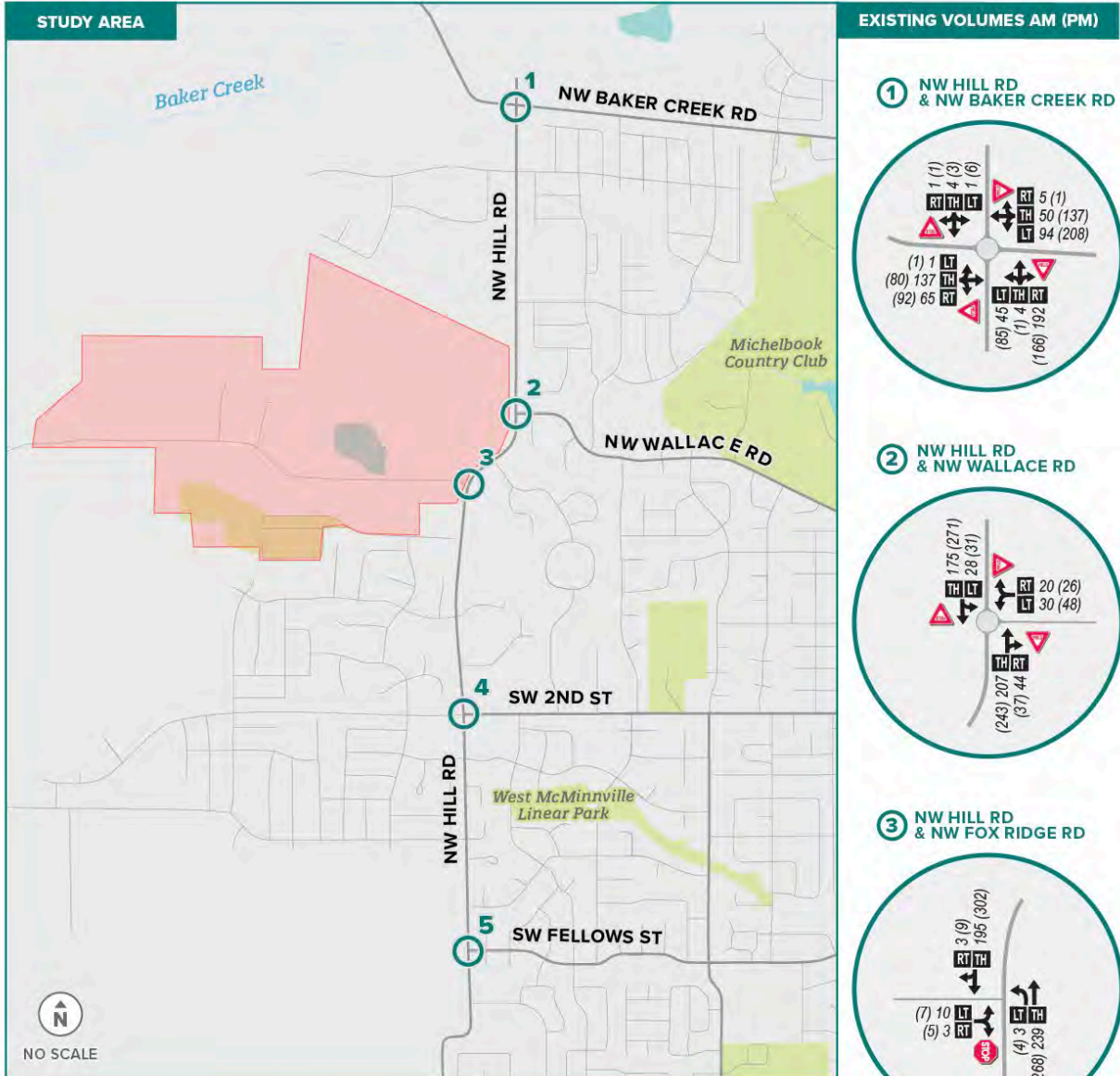

EXISTING VOLUMES AM (PM)

1 NW HILL RD & NW BAKER CREEK RD

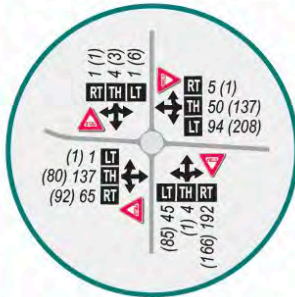

2 NW HILL RD & NW WALLACE RD

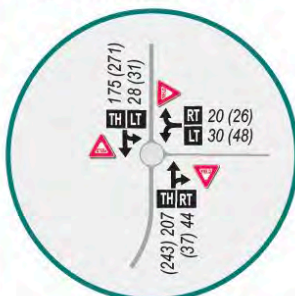

3 NW HILL RD & NW FOX RIDGE RD

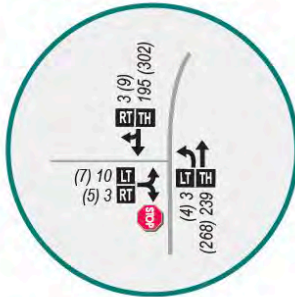

5 NW HILL RD & SW FELLOWS ST

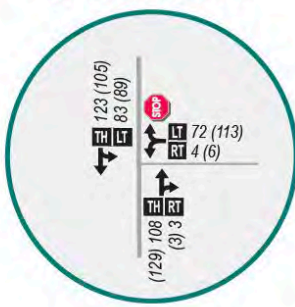

4 NW HILL RD & SW 2ND ST

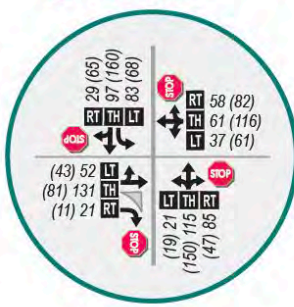

FIGURE 1: EXISTING 2023 TRAFFIC VOLUMES, LANE GEOMETRIES, AND TRAFFIC CONTROL

TABLE 1: EXISTING (2023) INTERSECTION OPERATIONS

INTERSECTION	TRAFFIC CONTROL	OPERATING STANDARD	AM PEAK HOUR			PM PEAK HOUR		
			V/C	DELAY	LOS	V/C	DELAY	LOS
NW HILL ROAD AT BAKER CREEK ROAD	Roundabout	v/c ≤ 0.90	0.25	5	A	0.29	5	A
NW HILL ROAD AT WALLACE ROAD	Roundabout	v/c ≤ 0.90	0.29	6	A	0.26	5	A
NW HILL ROAD AT FOX RIDGE ROAD	Two-Way Stop	v/c ≤ 0.90	0.03	12	B	0.03	12	B
NW HILL ROAD AT 2 ND ST	All-Way Stop	v/c ≤ 0.90	0.48	15	C	0.46	15	C
NW HILL ROAD AT FELLOWS ST	Two-Way Stop	v/c ≤ 0.90	0.11	10	A	0.15	10	A

Delay = Critical Approach Delay (secs)
v/c = Critical Approach Volume-to-Capacity Ratio
LOS = Critical Approach Level of Service
BOLD/RED = Does not meet the operating standard

BICYCLE, PEDESTRIAN, AND TRANSIT NEEDS

Bicycle, pedestrian, and transit conditions and needs were considered for the study area.

NW Hill Road between Baker Creek Road and 2nd Street was reconstructed with on-street bike lanes, gutter, curb, sidewalks, and a center turn lane/raised median since the TSP was adopted in 2010. There are still some gaps in the sidewalk along the west side of Hill Road adjacent to the Fox Ridge Road plan area that will be filled in as development and annexation occurs. The segment of NW Hill Road between 2nd Street and Alexandria Street is presently lacking in sidewalks, curb, gutter, and on-street bike lanes (wide paved shoulders for bikes are currently present).

Currently, there are no local transit routes that stop or travel along NW Hill Road. As the Fox Ridge Road area develops, transit routes and stops should be extended to residential and commercial locations along NW Hill Road.

PRIORITY TSP PROJECTS

The priority vehicle, pedestrian, and bicycle projects identified in the McMinnville TSP (2010) that are applicable to the Fox Ridge study area include the following. These improvements were not included in either of the future 2041 scenarios.

- Complete Streets Upgrade – NW Hill Road South (between 2nd Street and Alexandria Street) includes addition of on-street bicycle lanes and sidewalks
- Installation of a roundabout or traffic signal at NW Hill Road & 2nd Street

FUTURE BASELINE CONDITIONS (2041)

Future baseline (2041) traffic conditions were evaluated for the study area and include the forecasted baseline traffic volumes and intersection operations.

FUTURE BASELINE TRAFFIC VOLUMES

Future traffic volumes were forecasted for the study intersections using the travel forecast models developed specifically for McMinnville and maintained by the Transportation Planning Analysis Unit (TPAU).⁶ The existing year and future year volumes from the models were used to estimate an average annual vehicle growth rate on NW Hill Road. The growth was estimated to be approximately 4% per year along NW Hill Road, which is consistent with the current urban growth boundary and population estimates through 2041. This growth rate was applied to all study intersections and includes expected growth in the future Southwest area west of NW Hill Road near 2nd Street and Fellows Street, the mixed-use area on the northeast corner of Baker Creek Road and NW Hill Road, and the planned high school⁷ and elementary school⁸ near Wallace Road. A fourth leg was assumed at the Wallace Road intersection and the Fellows Street intersection to provide access to these future growth areas.

Figure 2 shows the AM and PM peak hour traffic volumes for the study intersections based on the model assumptions. Because these forecasts are consistent with the current McMinnville land use assumptions, this scenario is referred to as the 2041 “Baseline” scenario. This scenario already accounts for a small amount of low-density residential land use in the Fox Ridge Road plan area by 2041 (213 residential units) as well as the planned high school.

⁶ 2015 and 2041 Travel demand models maintained by ODOT TPAU.

⁷ The high school is assumed to support up to 1,160 students, consistent with the NW Hill Road: Traffic Analysis Study by CH2M Hill (March 1, 2016)

⁸ The elementary school is assumed to support up to 382 students, consistent with the NW Hill Road: Traffic Analysis Study by CH2M Hill (March 1, 2016).

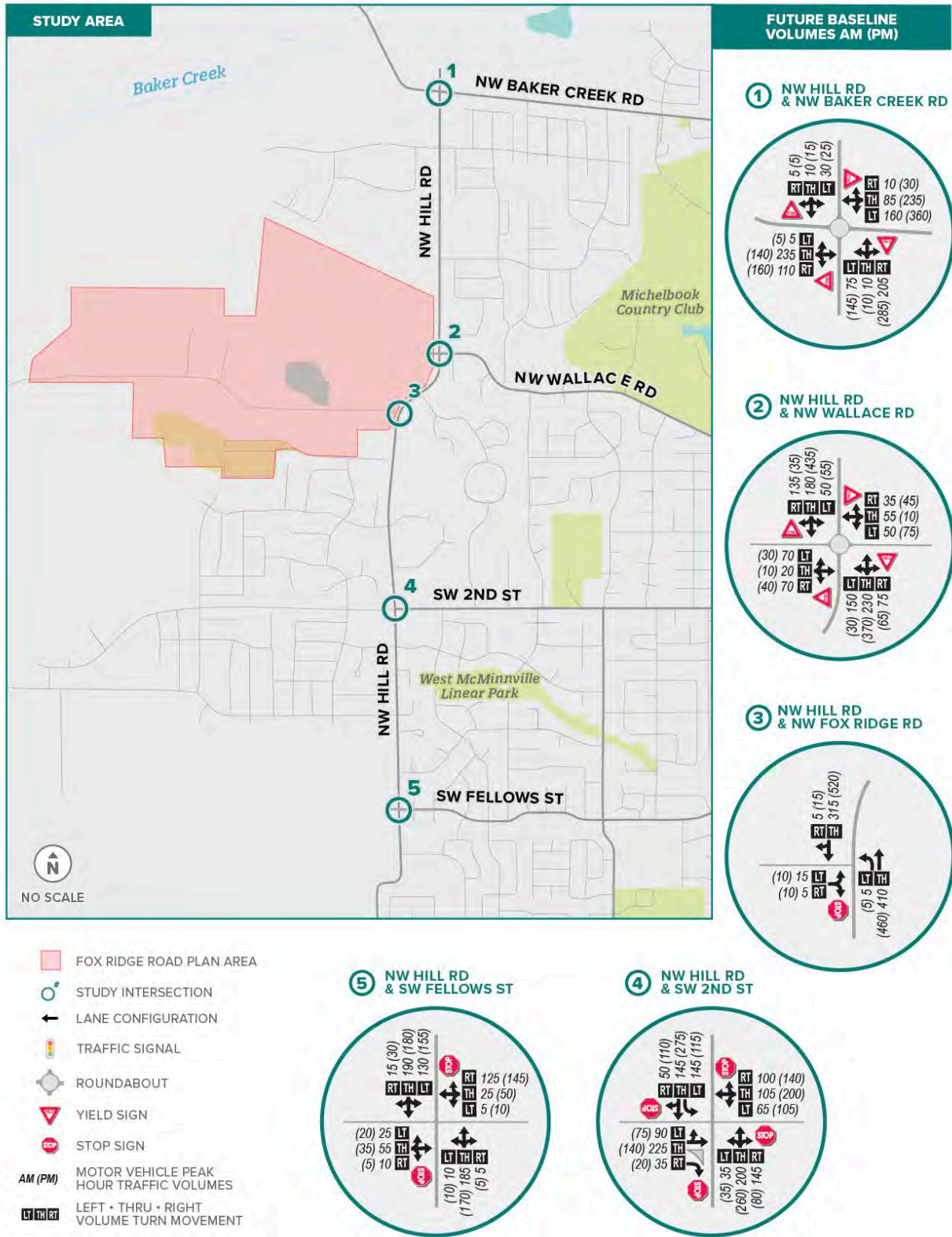

FIGURE 2: BASELINE (2041) TRAFFIC VOLUMES, LANE GEOMETRIES, AND TRAFFIC CONTROL

FUTURE BASELINE INTERSECTION OPERATIONS

Intersection traffic operations under the future 2041 Baseline scenario were analyzed for the AM and PM peak hour to evaluate whether the transportation network is expected to remain within desired performance levels as required by the City of McMinnville.

Table 2 lists the estimated average delay (in seconds), level of service (LOS), and volume to capacity (v/c) ratio that each study intersection and future access is expected to experience.

As shown, all intersections are expected to meet operating standards and targets under Baseline conditions with the exception of the NW Hill Road/2nd Street intersection. This intersection is estimated to experience high delays and operate over capacity by 2041 as an all-way stop-controlled intersection. The McMinnville TSP identified the need for a traffic control upgrade at this intersection.

TABLE 2: FUTURE BASELINE (2041) INTERSECTION OPERATIONS

INTERSECTION	TRAFFIC CONTROL	OPERATING STANDARD	AM PEAK HOUR			PM PEAK HOUR		
			V/C	DELAY	LOS	V/C	DELAY	LOS
NW HILL ROAD AT BAKER CREEK ROAD	Roundabout	v/c ≤ 0.90	0.37	7	A	0.56	9	A
NW HILL ROAD AT WALLACE ROAD	Roundabout	v/c ≤ 0.90	0.44	7	A	0.48	7	A
NW HILL ROAD AT FOX RIDGE ROAD	Two-Way Stop	v/c ≤ 0.90	0.06	15	B	0.07	17	C
NW HILL ROAD AT 2 ND ST	All-Way Stop	v/c ≤ 0.90	1.02	84	F	1.30	168	F
NW HILL ROAD AT FELLOWS ST	Two-Way Stop	v/c ≤ 0.90	0.35	25	C	0.28	26	D

Delay = Critical Approach Delay (secs)

v/c = Critical Approach Volume-to-Capacity Ratio

LOS = Critical Approach Level of Service

BOLD/RED = Does not meet the operating standard

PREFERRED LAND USE SCENARIO CONDITIONS (2041)

Preferred Land Use Scenario (2041) traffic conditions were evaluated for the study area and include the land use assumptions for the preferred scenario for the development of Fox Ridge Area, anticipated intersection operations, and identified transportation improvements.

PREFERRED LAND USE ASSUMPTIONS

As mentioned previously, the future year 2041 McMinnville Travel Demand model currently assumes some amount of low-density residential development and the planned high school⁹ within the Fox Ridge Road plan area. It also included the expected growth in the future Southwest area west of NW Hill Road near 2nd Street and Fellows Street, the mixed-use area on the northeast corner of Baker Creek Road and NW Hill Road, and the planned elementary school¹⁰ near Wallace Road.

Based on the Preferred Land Use scenario, the quantity of anticipated housing units and size of commercial-retail space in the Fox Ridge Road plan area exceeds what is currently assumed in the travel demand model. Therefore, additional vehicle trips representing the additional land uses must be estimated and added to the Baseline scenario to represent the Preferred Land Use scenario.

The table below shows the estimated residential units and commercial-retail space for both the 2041 Baseline scenario and the 2041 Preferred Land Use Scenario. As shown, under the Preferred Land Use Scenario concept, the estimated reasonable number of housing units is 710 (mix of low-, medium-, and high-density) and approximately 23,000 square feet of commercial-retail gross floor area.

Because the Baseline scenario already accounted for 213 residential units, the net increase is 497 residential units and 23 KSF of commercial-retail gross floor area due to the full buildout of the Preferred Land Use scenario.

TABLE 3: LAND USE ASSUMPTIONS

SCENARIO	RESIDENTIAL (UNITS)	COMMERCIAL-RETAIL (KSF) ^a
2041 BASELINE	213	0
2041 PREFERRED LAND USE SCENARIO	710	23
NET INCREASE	+497	+23

^a KSF = 1,000 square feet

To analyze the impacts of the Preferred Land Use scenario on the study area, DKS obtained trip generation rates from the McMinnville Travel Demand model for the residential vehicle trips to

⁹ The high school is assumed to support up to 1,160 students, consistent with the NW Hill Road: Traffic Analysis Study by CH2M Hill (March 1, 2016)

¹⁰ The elementary school is assumed to support up to 382 students, consistent with the NW Hill Road: Traffic Analysis Study by CH2M Hill (March 1, 2016).

estimate the additional amount of vehicle traffic generated by the Preferred Land Use scenario. The commercial-retail trip generation was estimated using trip rates from the Institute of Transportation Engineers (ITE) Trip Generation Manual for Land Use 822. These assumptions were coordinated with the City of McMinnville and ODOT staff.

The trip generation rates for residential and commercial-retail land use were then applied to the estimated net increase of housing units and square feet of commercial-retail land use (Table 3). The resulting trip generation for the AM and PM peak hours is presented in Table 4.

TABLE 4: VEHICLE TRIP GENERATION

LAND USE	SIZE	AM TRIP RATE	PM TRIP RATE	TRIP RATE SOURCE	AM PEAK HOUR			PM PEAK HOUR		
					IN	OUT	TOTAL	IN	OUT	TOTAL
RESIDENTIAL	497 units	0.55 trips/unit	0.74 trips/unit	McMinnville Travel Demand Model	68	205	273	232	136	368
COMMERCIAL-RETAIL	23 KSF	2.36 trips/KSF	6.59 trips/KSF	ITE Trip Generation Manual	32	22	54	76	76	152
TRIP GENERATION					100	227	327	308	212	520

It should be noted that no internal trip reduction was applied to the trip generation estimates above. While it is common practice to apply a reduction factor to account for internal trips within a mixed-use development, the land use within the mixed-use area is only conceptual at this point in time and detailed land use breakdowns (i.e., office space vs retail space vs hotel) are not known. The number of housing units and overall building square footages within the mixed-use area were estimated based on typical land use densities, and accounting for internal trip capture would introduce another layer of uncertainty to the trip generation estimates. Because of this, it was not practical or appropriate to calculate an internal trip reduction factor based on the NCHRP 684 methodology in this traffic study, of which the main goal is to help identify and inform high-level transportation issues that would need to be addressed in the City’s Transportation System Plan update. Internal trip reductions should be included in the future traffic studies that will be required as development occurs within the Fox Ridge Road plan area.

These vehicle trips were then distributed through the study area based on distribution data from the McMinnville Travel Demand model. The trip distribution was as follows. The trip distribution assumptions were coordinated with City and ODOT staff.

- 5% of trips via NW Baker Creek Road (west of city limits)
- 30% of trips via NW Baker Creek Road (east of NW Hill Rd)
- 15% of trips via NW Wallace Road
- 30% of trips via SW 2nd Street (east)
- 5% of trips via SW 2nd Street (west)
- 10% of trips via SW Fellows Street
- 5% of trips via SW NW Hill Road south of SW Fellows Street

PREFERRED LAND USE SCENARIO TRAFFIC VOLUMES

The future 2041 Preferred Scenario traffic volumes were estimated by adding the 2041 Future Baseline volumes and the vehicle trips as shown in Table 4.

Intersection operations were then evaluated to determine how sufficiently the City's future transportation system would support the long-term estimated build-out of the Fox Ridge Road area, therefore determining what improvements might be needed. The AM and PM peak hour traffic volumes, lane geometries, and intersection operating conditions are shown in Figure 3.

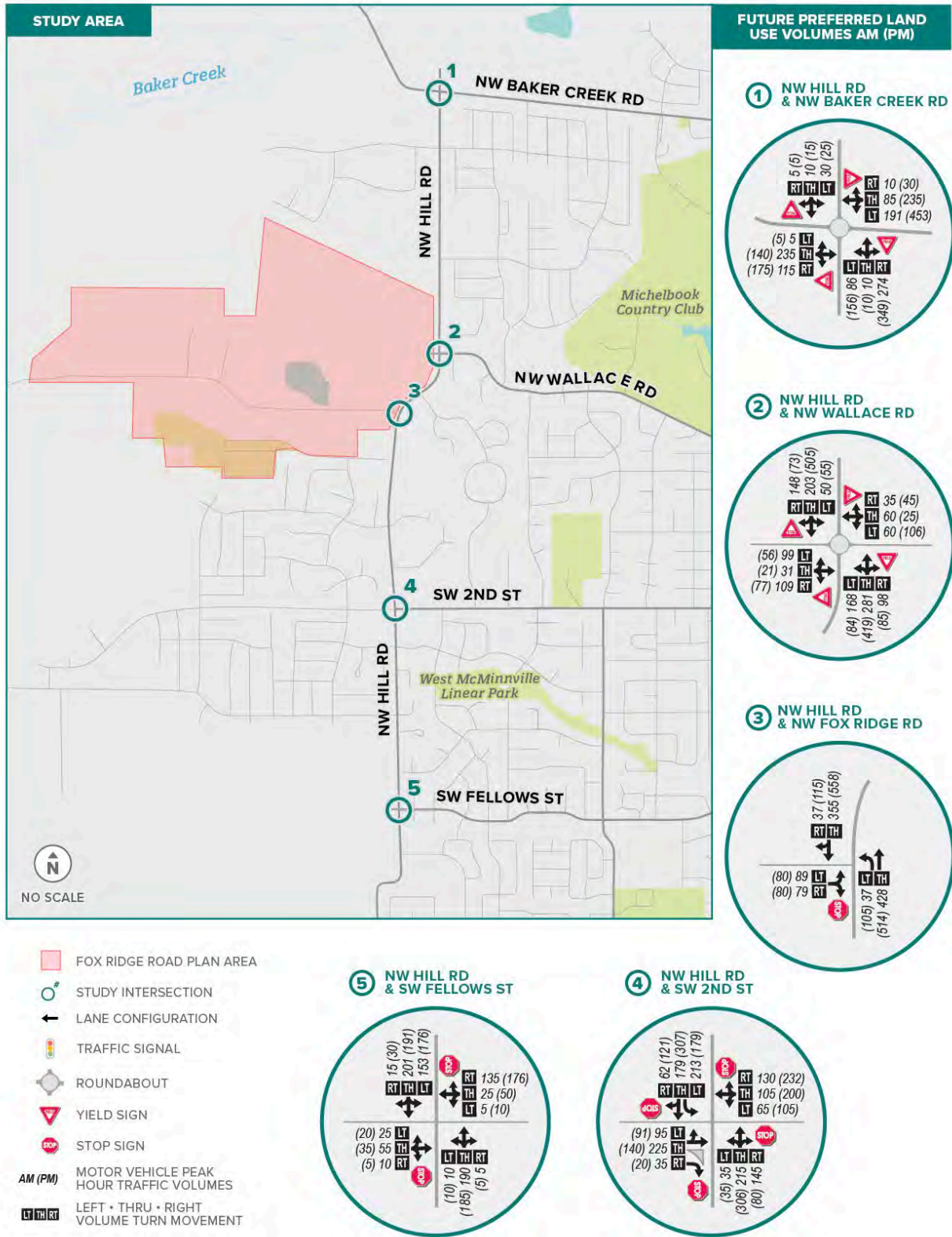

FIGURE 3: PREFERRED LAND USE (2041) TRAFFIC VOLUMES, LANE GEOMETRIES, AND TRAFFIC CONTROL

PREFERRED LAND USE SCENARIO INTERSECTION OPERATIONS

Intersection traffic operations under the future 2041 Preferred Land Use scenario were analyzed for the AM and PM peak hours with the same intersection geometries that were assumed in the Baseline scenario. Table 5 the estimated average delay (in seconds), level of service (LOS), and volume to capacity (v/c) ratio for each study intersection.

TABLE 5: PREFERRED LAND USE SCENARIO (2041) INTERSECTION OPERATIONS

INTERSECTION	TRAFFIC CONTROL	OPERATING STANDARD	AM PEAK HOUR			PM PEAK HOUR		
			V/C	DELAY	LOS	V/C	DELAY	LOS
NW HILL ROAD AT BAKER CREEK ROAD	Roundabout	v/c ≤ 0.90	0.42	7	A	0.65	10	B
NW HILL ROAD AT WALLACE ROAD	Roundabout	v/c ≤ 0.90	0.55	9	A	0.65	10	B
NW HILL ROAD AT FOX RIDGE ROAD	Two-Way Stop	v/c ≤ 0.90	0.51	25	C	0.91	92	F
NW HILL ROAD AT 2 ND ST	All-Way Stop	v/c ≤ 0.90	1.16	134	F	1.64	276	F
NW HILL ROAD AT FELLOWS ST	Two-Way Stop	v/c ≤ 0.90	0.40	29	D	0.34	33	D

Delay = Critical Approach Delay (secs)
v/c = Critical Approach Volume-to-Capacity Ratio
LOS = Critical Approach Level of Service
BOLD/RED = Does not meet the operating standard

As shown, the stop-controlled intersections of Fox Ridge Road and 2nd Street along NW Hill Road are expected to exceed the City’s mobility standard.

Under the 2041 Baseline conditions, the intersection of 2nd Street was also shown to fail to meet the City’s mobility standard (Table 2). This is due to the high level of growth and development that is expected along Hill Road through 2041. The comparison of Baseline to Preferred Land Use scenarios shows that the failure of 2nd Street is not just attributed to the Fox Ridge Road growth, but due also in part to the growth in the Southwest area, the Baker Creek mixed-use area, and the planned elementary school.

The Fox Ridge Road intersection does not meet the City’s mobility standard under the full buildout of the Preferred Land Use scenario only.

PRIORITY TSP PROJECTS

As previously noted in an earlier section of the report, the priority vehicle, pedestrian, and bicycle projects identified in the McMinnville TSP (2010) that are applicable to the Fox Ridge study area include the following. These improvements were not included in any of the future 2041 scenarios.

- Complete Streets Upgrade – NW Hill Road South (between 2nd Street and Alexandria Street) includes addition of on-street bicycle lanes and sidewalks
- Installation of a roundabout or traffic signal at NW Hill Road & 2nd Street

RECOMMENDED TRANSPORTATION IMPROVEMENTS

The following improvement projects have been identified to address the vehicle operations at the two intersections along NW Hill Road to meet the City's v/c ratio performance standard. The recommended improvements are described below.

NW HILL ROAD AT FOX RIDGE ROAD

At this intersection, install a single-lane roundabout or traffic signal. In addition to meeting capacity needs and improving vehicle delay, the proposed roundabout or traffic signal would provide safe pedestrian, bicycle, and vehicle access to the Fox Ridge Road plan area. The single-lane roundabout would calm vehicle traffic on NW Hill Road near the planned schools and also provide higher safety benefits compared to the traffic signal. See the list of *Advantages of Installing A Roundabout*.

The intersection was initially analyzed with a stop-control on the minor street approach (Fox Ridge Road) with two separate left and right turn approach lanes. This lane configuration would reduce the v/c ratio to within the City's performance standard; however, the average delay would still exceed an average of 85 seconds on the Fox Ridge Road approach (LOS F). Often, high vehicle delays associated with LOS F result in impatient drivers that accept smaller gaps in traffic when making left turns which can increase vehicle crashes and cause safety issues for all modes of travel. Therefore, it is recommended that a single-lane roundabout or traffic signal be included as part of the transportation improvements for the Fox Ridge Road Area Plan.

NW HILL ROAD AT 2ND STREET

At this intersection, install a single-lane roundabout or traffic signal. A single lane-roundabout and a traffic signal with northbound left turn lane both provide adequate vehicular capacity and reduce vehicle delay through 2041. The current TSP (2010) indicates the need for a roundabout or traffic signal at this intersection. The single-lane roundabout would calm vehicle traffic on NW Hill Road by slowing vehicle speeds and provide higher safety benefits compared to the traffic signal. See the list of *Advantages of Installing A Roundabout*.

IMPROVED OPERATING CONDITIONS

The table below shows the intersection operations for the two intersections with the identified transportation improvements in place. As shown, the intersections will meet the City LOS standard while providing safe multimodal improvements for pedestrians and bicycles.

TABLE 6: PREFERRED LAND USE SCENARIO (2041) INTERSECTION OPERATIONS – WITH IMPROVEMENTS

INTERSECTION	IMPROVEMENT	OPERATING STANDARD	AM PEAK HOUR			PM PEAK HOUR		
			V/C	DELAY	LOS	V/C	DELAY	LOS
NW HILL ROAD AT FOX RIDGE ROAD	Roundabout	v/c ≤ 0.90	0.42	6	A	0.61	9	A
	Traffic Signal	v/c ≤ 0.90	0.46	8	A	0.58	7	A
NW HILL ROAD AT 2 ND ST	Roundabout	v/c ≤ 0.90	0.63	12	B	0.74	16	C
	Traffic Signal	v/c ≤ 0.90	0.77	32	C	0.89	40	D

Delay = Critical Movement Delay (secs)
v/c = Critical Movement Volume-to-Capacity Ratio
LOS = Critical Levels of Service (Major/Minor Road)

Advantages of Installing a Roundabout

- Roundabouts can reduce delay for side street traffic because no approach is given more priority than another.
- Roundabouts can help to slow traffic speeds on the major roadway. Typical circulating speeds for a roundabout are 15 – 20 miles per hour (mph), which would help to calm traffic in the vicinity of the Fox Ridge Road plan area and near the planned schools.
- Converting a stop-controlled intersection to a single-lane roundabout can reduce fatal and injury crashes by 82%.
- Roundabouts reduce the number of conflict points between vehicles and between vehicles and pedestrians/bicycles.

Disadvantages of Installing a Roundabout

- Because all approaches are treated the same and must yield to traffic within the roundabout, this would introduce delay for traffic on the major approaches (NW Hill Road).
- Roundabouts are more difficult for large trucks and agricultural vehicles to navigate and may result in complaints from the freight and agricultural community.

- Roundabouts can be difficult for school aged pedestrians and bicyclists to cross because there is no exclusive stop phase (as is provided with a traffic signal). The lack of straight paths and clear turns can also be difficult for people who are visually impaired.
- Roundabouts often require a larger footprint, which can require additional right-of-way dedication or acquisition.

SUMMARY & RECOMMENDATION

A summary of the transportation analysis and recommendations is provided below:

- The Fox Ridge Road Plan Area includes over 200 acres of land and the preferred development plan for the area primarily includes a mix of residential housing (low-, medium-, and high-density), parks and open spaces, some neighborhood mixed-use development, and a high school.
- The transportation analysis focused on five major intersections along NW Hill Road.
- Today, vehicle operations at the five study intersections meet the City's standard.
- New sidewalks, on-street bicycle lanes, and a raised center median were recently constructed along NW Hill Road between Baker Creek Road and 2nd Street, providing sufficient multimodal facilities along that northern half of NW Hill Road. However, the southern half of NW Hill Road south of 2nd Street is lacking in sidewalks, bicycle facilities, curb, and gutter.
- Currently, there are no local transit routes that stop or travel along NW Hill Road. As the Fox Ridge Road area develops, transit routes and stops should be extended to residential and commercial locations along NW Hill Road.
- Under the Preferred Land Use scenario, two of the study intersections on NW Hill Road fail to meet the City's operating standard, NW Hill Road & Fox Ridge Road and NW Hill Road & 2nd Street.
- The recommended intersection improvements at the two intersections are listed below:
 - **NW Hill Road at Fox Ridge Road:** Install a single-lane roundabout or traffic signal. This project is not listed in the City's current TSP (2010).
 - **NW Hill Road at 2nd Street:** Install a single-lane roundabout or traffic signal. This is consistent with the priority project identified in the City's current TSP (2010).

APPENDIX

CONTENTS

TRAFFIC COUNT DATA

LOS DESCRIPTION

EXISTING 2023 HCM REPORTS

FUTURE BASELINE 2041 HCM REPORTS

PREFERRED SCENARIO 2041 HCM REPORTS

RECOMMENDED IMPROVEMENTS HCM REPORTS

TRAVEL DEMAND MODEL OUTPUTS & ODOT CORRESPONDENCE

TRIP GENERATION VOLUME FIGURE

TRAFFIC COUNT DATA



(303) 216-2439
www.alltrafficdata.net

Location: 1 NW HILL RD & NW BAKER CREEK RD AM

Date: Thursday, June 1, 2023

Peak Hour: 07:20 AM - 08:20 AM

Peak 15-Minutes: 07:50 AM - 08:05 AM

DRAFT

Peak Hour

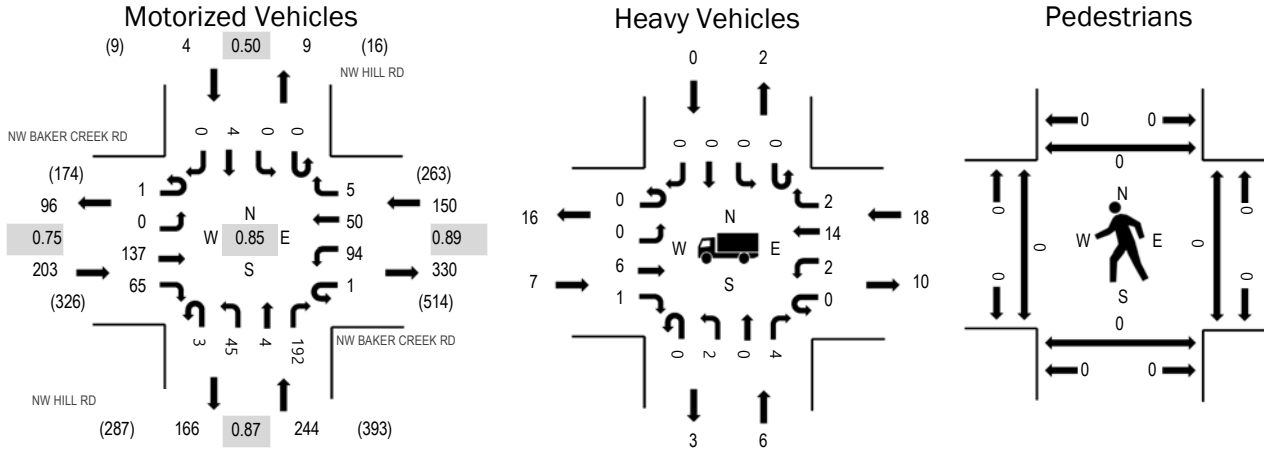

Note: Total study counts contained in parentheses.

	HV%	PHF
EB	3.4%	0.75
WB	12.0%	0.89
NB	2.5%	0.87
SB	0.0%	0.50
All	5.2%	0.85

Traffic Counts - Motorized Vehicles

Interval Start Time	NW BAKER CREEK RD Eastbound				NW BAKER CREEK RD Westbound				NW HILL RD Northbound				NW HILL RD Southbound				Total	Rolling Hour
	U-Turn	Left	Thru	Right	U-Turn	Left	Thru	Right	U-Turn	Left	Thru	Right	U-Turn	Left	Thru	Right		
7:00 AM	0	0	5	3	0	3	1	0	0	4	1	8	0	0	0	0	25	517
7:05 AM	0	0	3	4	0	6	1	0	0	1	0	11	0	0	0	0	26	547
7:10 AM	0	0	5	8	0	4	1	1	0	3	1	8	0	0	0	0	31	569
7:15 AM	0	0	9	3	0	4	0	2	0	5	0	13	0	0	0	0	36	591
7:20 AM	1	0	5	6	0	9	6	1	1	3	1	14	0	0	0	0	47	601
7:25 AM	0	0	7	5	0	4	3	0	0	3	0	14	0	0	0	0	36	594
7:30 AM	0	0	11	1	0	6	3	0	0	4	0	10	0	0	1	0	36	592
7:35 AM	0	0	19	6	0	9	3	0	0	6	0	17	0	0	2	0	62	585
7:40 AM	0	0	10	5	0	9	2	0	0	7	0	13	0	0	0	0	46	557
7:45 AM	0	0	11	9	0	5	4	0	0	2	0	19	0	0	0	0	50	549
7:50 AM	0	0	20	5	0	6	4	0	1	4	1	19	0	0	0	0	60	532
7:55 AM	0	0	14	5	1	13	4	0	1	4	0	20	0	0	0	0	62	507
8:00 AM	0	0	13	11	0	7	5	1	0	1	0	17	0	0	0	0	55	474
8:05 AM	0	0	7	6	0	11	2	0	0	3	1	18	0	0	0	0	48	
8:10 AM	0	0	10	3	0	9	5	2	0	4	0	20	0	0	0	0	53	
8:15 AM	0	0	10	3	0	6	9	1	0	4	1	11	0	0	1	0	46	
8:20 AM	0	0	8	6	1	7	6	0	0	3	0	8	0	0	1	0	40	
8:25 AM	0	0	5	3	0	7	3	0	0	4	1	10	0	1	0	0	34	
8:30 AM	0	0	8	2	0	4	4	0	0	3	0	8	0	0	0	0	29	
8:35 AM	0	0	8	3	0	8	6	0	0	2	0	6	0	0	0	1	34	
8:40 AM	0	0	5	5	0	7	7	1	0	3	0	8	0	1	1	0	38	
8:45 AM	0	0	6	3	0	12	5	0	1	2	0	4	0	0	0	0	33	
8:50 AM	0	0	9	4	0	4	2	0	0	7	0	9	0	0	0	0	35	
8:55 AM	0	0	4	4	0	4	2	0	0	2	0	13	0	0	0	0	29	
Count Total	1	0	212	113	2	164	88	9	4	84	7	298	0	2	6	1	991	
Peak Hour	1	0	137	65	1	94	50	5	3	45	4	192	0	0	4	0	601	

Traffic Counts - Heavy Vehicles, Bicycles on Road, and Pedestrians/Bicycles on Crosswalk

Interval Start Time	Heavy Vehicles					Interval Start Time	Bicycles on Roadway					Interval Start Time	Pedestrians/Bicycles on Crosswalk				
	EB	NB	WB	SB	Total		EB	NB	WB	SB	Total		EB	NB	WB	SB	Total
7:00 AM	1	0	0	0	1	7:00 AM	0	0	0	0	0	7:00 AM	0	0	0	0	0
7:05 AM	0	0	1	0	1	7:05 AM	0	0	0	0	0	7:05 AM	0	0	0	0	0
7:10 AM	0	2	2	0	4	7:10 AM	0	0	0	0	0	7:10 AM	0	0	0	0	0
7:15 AM	2	0	1	0	3	7:15 AM	0	0	0	0	0	7:15 AM	0	0	0	0	0
7:20 AM	0	0	2	0	2	7:20 AM	0	0	0	0	0	7:20 AM	0	0	0	0	0
7:25 AM	0	0	0	0	0	7:25 AM	0	0	0	0	0	7:25 AM	0	0	0	0	0
7:30 AM	1	0	0	0	1	7:30 AM	0	0	0	0	0	7:30 AM	0	0	0	0	0
7:35 AM	1	0	1	0	2	7:35 AM	0	0	0	0	0	7:35 AM	0	0	0	0	0
7:40 AM	0	0	0	0	0	7:40 AM	0	0	0	0	0	7:40 AM	0	0	0	0	0
7:45 AM	0	1	3	0	4	7:45 AM	0	0	0	0	0	7:45 AM	0	0	0	0	0
7:50 AM	0	0	1	0	1	7:50 AM	0	0	0	0	0	7:50 AM	0	0	0	0	0
7:55 AM	0	1	0	0	1	7:55 AM	0	0	0	0	0	7:55 AM	0	0	0	0	0
8:00 AM	1	1	2	0	4	8:00 AM	0	0	0	0	0	8:00 AM	0	0	0	0	0
8:05 AM	0	2	2	0	4	8:05 AM	0	0	0	0	0	8:05 AM	0	0	0	0	0
8:10 AM	0	1	3	0	4	8:10 AM	0	0	0	0	0	8:10 AM	0	0	0	0	0
8:15 AM	4	0	4	0	8	8:15 AM	0	0	0	0	0	8:15 AM	0	0	0	0	0
8:20 AM	2	0	0	0	2	8:20 AM	0	0	0	0	0	8:20 AM	0	0	0	0	0
8:25 AM	1	0	0	1	2	8:25 AM	0	0	0	0	0	8:25 AM	0	0	0	0	0
8:30 AM	1	0	1	0	2	8:30 AM	0	0	0	0	0	8:30 AM	0	0	0	0	0
8:35 AM	0	0	1	1	2	8:35 AM	0	0	0	0	0	8:35 AM	0	1	0	1	2
8:40 AM	1	0	1	0	2	8:40 AM	0	0	0	0	0	8:40 AM	0	0	0	0	0
8:45 AM	0	0	0	0	0	8:45 AM	0	0	0	0	0	8:45 AM	0	0	0	0	0
8:50 AM	0	1	0	0	1	8:50 AM	0	0	0	0	0	8:50 AM	0	0	0	0	0
8:55 AM	1	0	0	0	1	8:55 AM	0	0	0	0	0	8:55 AM	0	0	0	0	0
Count Total	16	9	25	2	52	Count Total	0	0	0	0	0	Count Total	0	1	0	1	2
Peak Hour	7	6	18	0	31	Peak Hour	0	0	0	0	0	Peak Hour	0	0	0	0	0



(303) 216-2439
www.alltrafficdata.net

Location: 2 NW HILL RD & NW WALLACE RD AM

Date: Thursday, June 1, 2023

Peak Hour: 07:15 AM - 08:15 AM

Peak 15-Minutes: 07:50 AM - 08:05 AM

DRAFT

Peak Hour

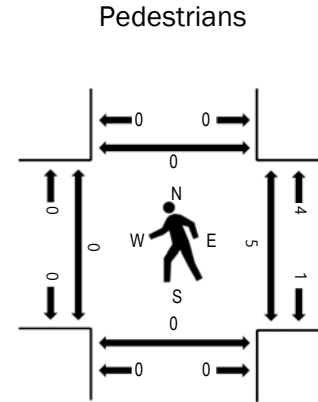
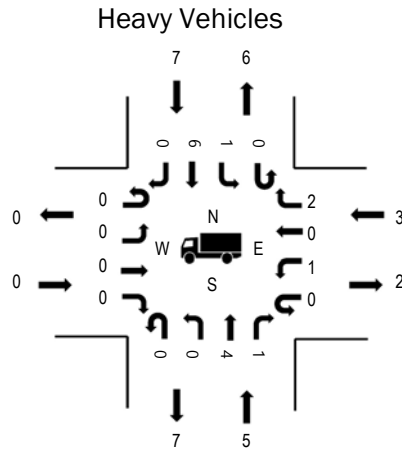
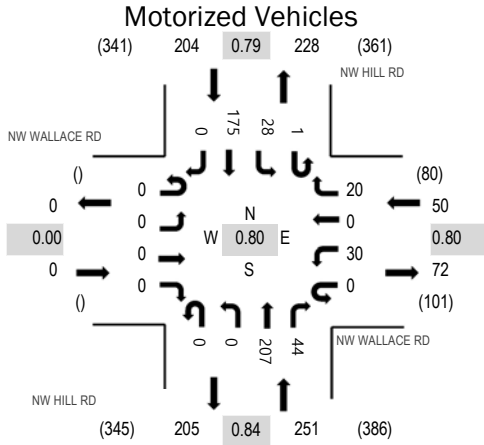

Note: Total study counts contained in parentheses.

	HV%	PHF
EB	0.0%	0.00
WB	6.0%	0.80
NB	2.0%	0.84
SB	3.4%	0.79
All	3.0%	0.80

Traffic Counts - Motorized Vehicles

Interval Start Time	NW WALLACE RD Eastbound				NW WALLACE RD Westbound				NW HILL RD Northbound				NW HILL RD Southbound				Total	Rolling Hour
	U-Turn	Left	Thru	Right	U-Turn	Left	Thru	Right	U-Turn	Left	Thru	Right	U-Turn	Left	Thru	Right		
7:00 AM	0	0	0	0	0	0	0	3	0	0	6	2	0	1	7	0	19	427
7:05 AM	0	0	0	0	0	3	0	0	0	0	12	1	0	0	5	0	21	462
7:10 AM	0	0	0	0	0	1	0	1	0	0	6	1	0	0	14	0	23	484
7:15 AM	0	0	0	0	0	0	0	2	0	0	14	3	0	1	14	0	34	505
7:20 AM	0	0	0	0	0	2	0	0	0	0	17	4	0	1	12	0	36	503
7:25 AM	0	0	0	0	0	1	0	0	0	0	9	2	0	3	9	0	24	494
7:30 AM	0	0	0	0	0	5	0	1	0	0	16	4	0	0	12	0	38	503
7:35 AM	0	0	0	0	0	0	0	3	0	0	18	5	0	0	13	0	39	491
7:40 AM	0	0	0	0	0	2	0	2	0	0	15	3	0	3	18	0	43	469
7:45 AM	0	0	0	0	0	3	0	1	0	0	17	3	0	5	18	0	47	446
7:50 AM	0	0	0	0	0	3	0	3	0	0	20	7	0	3	15	0	51	425
7:55 AM	0	0	0	0	0	4	0	2	0	0	20	4	1	3	18	0	52	400
8:00 AM	0	0	0	0	0	2	0	3	0	0	19	5	0	5	20	0	54	380
8:05 AM	0	0	0	0	0	7	0	1	0	0	16	2	0	4	13	0	43	
8:10 AM	0	0	0	0	0	1	0	2	0	0	26	2	0	0	13	0	44	
8:15 AM	0	0	0	0	0	5	0	0	0	0	15	2	0	1	9	0	32	
8:20 AM	0	0	0	0	0	2	0	2	0	0	8	1	0	1	13	0	27	
8:25 AM	0	0	0	0	0	4	0	3	0	0	11	0	0	5	10	0	33	
8:30 AM	0	0	0	0	0	0	0	1	0	0	10	4	0	1	10	0	26	
8:35 AM	0	0	0	0	0	1	0	1	1	0	6	1	0	1	6	0	17	
8:40 AM	0	0	0	0	0	0	0	0	0	0	6	0	0	1	13	0	20	
8:45 AM	0	0	0	0	0	1	0	0	0	0	6	1	1	0	17	0	26	
8:50 AM	0	0	0	0	0	0	0	2	0	0	17	0	1	1	5	0	26	
8:55 AM	0	0	0	0	0	0	0	0	0	0	15	3	0	1	13	0	32	
Count Total	0	0	0	0	0	47	0	33	1	0	325	60	3	41	297	0	807	
Peak Hour	0	0	0	0	0	30	0	20	0	0	207	44	1	28	175	0	505	

Traffic Counts - Heavy Vehicles, Bicycles on Road, and Pedestrians/Bicycles on Crosswalk

Interval Start Time	Heavy Vehicles					Interval Start Time	Bicycles on Roadway					Interval Start Time	Pedestrians/Bicycles on Crosswalk				
	EB	NB	WB	SB	Total		EB	NB	WB	SB	Total		EB	NB	WB	SB	Total
7:00 AM	0	0	0	0	0	7:00 AM	0	0	0	0	0	7:00 AM	0	0	0	0	0
7:05 AM	0	1	0	0	1	7:05 AM	0	0	0	0	0	7:05 AM	0	0	0	0	0
7:10 AM	0	0	0	0	0	7:10 AM	0	0	0	0	0	7:10 AM	0	0	0	0	0
7:15 AM	0	0	0	3	3	7:15 AM	0	0	0	0	0	7:15 AM	0	0	2	0	2
7:20 AM	0	0	0	1	1	7:20 AM	0	0	0	0	0	7:20 AM	0	0	2	0	2
7:25 AM	0	0	0	0	0	7:25 AM	0	0	0	0	0	7:25 AM	0	0	0	0	0
7:30 AM	0	0	0	0	0	7:30 AM	0	0	0	0	0	7:30 AM	0	0	0	0	0
7:35 AM	0	0	0	0	0	7:35 AM	0	0	0	0	0	7:35 AM	0	0	0	0	0
7:40 AM	0	0	0	0	0	7:40 AM	0	0	0	0	0	7:40 AM	0	0	0	0	0
7:45 AM	0	1	1	0	2	7:45 AM	0	0	0	0	0	7:45 AM	0	0	0	0	0
7:50 AM	0	0	0	1	1	7:50 AM	0	0	0	0	0	7:50 AM	0	0	1	0	1
7:55 AM	0	1	1	1	3	7:55 AM	0	0	0	0	0	7:55 AM	0	0	0	0	0
8:00 AM	0	2	0	0	2	8:00 AM	0	0	0	0	0	8:00 AM	0	0	0	0	0
8:05 AM	0	1	0	0	1	8:05 AM	0	0	0	0	0	8:05 AM	0	0	0	0	0
8:10 AM	0	0	1	1	2	8:10 AM	0	0	0	0	0	8:10 AM	0	0	0	0	0
8:15 AM	0	0	0	1	1	8:15 AM	0	0	0	0	0	8:15 AM	0	0	0	0	0
8:20 AM	0	0	0	1	1	8:20 AM	0	0	0	0	0	8:20 AM	0	0	2	0	2
8:25 AM	0	0	0	0	0	8:25 AM	0	0	0	0	0	8:25 AM	0	0	1	0	1
8:30 AM	0	0	0	0	0	8:30 AM	0	0	0	0	0	8:30 AM	0	0	0	0	0
8:35 AM	0	0	0	0	0	8:35 AM	0	0	0	0	0	8:35 AM	0	0	0	0	0
8:40 AM	0	0	0	0	0	8:40 AM	0	0	0	0	0	8:40 AM	0	0	1	0	1
8:45 AM	0	0	0	0	0	8:45 AM	0	0	0	0	0	8:45 AM	0	0	0	0	0
8:50 AM	0	1	0	0	1	8:50 AM	0	0	0	0	0	8:50 AM	0	0	0	0	0
8:55 AM	0	0	0	0	0	8:55 AM	0	0	0	0	0	8:55 AM	0	0	0	0	0
Count Total	0	7	3	9	19	Count Total	0	0	0	0	0	Count Total	0	0	9	0	9
Peak Hour	0	5	3	7	15	Peak Hour	0	0	0	0	0	Peak Hour	0	0	5	0	5



(303) 216-2439
www.alltrafficdata.net

Location: 3 NW HILL RD & SW 2ND ST AM
Date: Thursday, June 1, 2023
Peak Hour: 07:30 AM - 08:30 AM
Peak 15-Minutes: 07:40 AM - 07:55 AM

DRAFT

Peak Hour

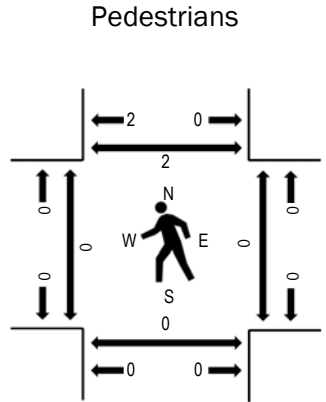
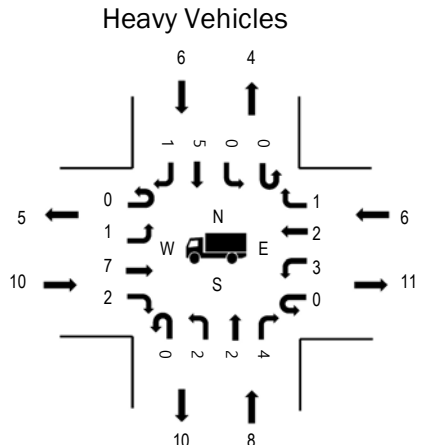
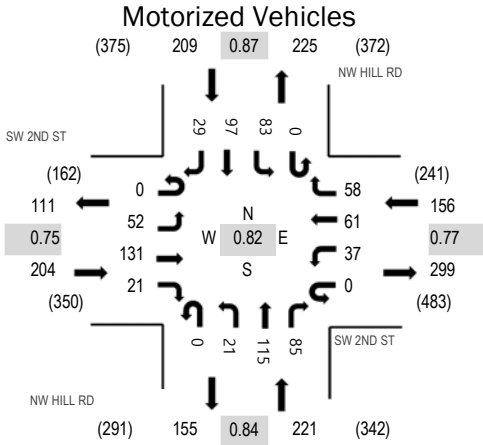

Note: Total study counts contained in parentheses.

	HV%	PHF
EB	4.9%	0.75
WB	3.8%	0.77
NB	3.6%	0.84
SB	2.9%	0.87
All	3.8%	0.82

Traffic Counts - Motorized Vehicles

Interval Start Time	SW 2ND ST Eastbound				SW 2ND ST Westbound				NW HILL RD Northbound			NW HILL RD Southbound				Total	Rolling Hour	
	U-Turn	Left	Thru	Right	U-Turn	Left	Thru	Right	U-Turn	Left	Thru	Right	U-Turn	Left	Thru			Right
7:00 AM	0	0	1	3	0	1	1	3	0	0	2	4	0	1	9	0	25	673
7:05 AM	0	5	7	0	0	1	1	3	0	0	7	0	0	4	4	1	33	715
7:10 AM	0	1	7	1	0	1	0	1	0	1	4	3	0	4	14	2	39	757
7:15 AM	0	7	12	1	0	1	1	4	0	0	7	5	0	8	7	0	53	786
7:20 AM	0	3	8	3	0	1	0	2	0	1	12	3	0	7	7	2	49	781
7:25 AM	0	4	15	2	0	1	2	5	0	0	5	3	0	6	3	3	49	785
7:30 AM	0	6	12	0	0	3	2	2	0	0	7	3	0	3	8	1	47	790
7:35 AM	0	2	11	1	0	3	5	3	0	0	12	8	0	10	7	4	66	787
7:40 AM	0	6	17	3	0	1	3	4	0	3	12	8	0	4	12	3	76	762
7:45 AM	0	5	23	2	0	4	5	3	0	4	7	10	0	14	6	2	85	721
7:50 AM	0	4	12	3	0	6	4	8	0	1	17	3	0	8	11	3	80	685
7:55 AM	0	8	11	0	0	3	3	7	0	4	11	9	0	7	4	4	71	657
8:00 AM	0	7	7	2	0	2	1	5	0	2	6	9	0	13	11	2	67	635
8:05 AM	0	3	13	1	0	1	13	9	0	2	9	6	0	3	12	3	75	
8:10 AM	0	3	7	1	0	5	7	6	0	1	11	11	0	10	5	1	68	
8:15 AM	0	3	8	3	0	5	3	3	0	1	7	5	0	2	7	1	48	
8:20 AM	0	3	5	2	0	1	8	3	0	3	4	8	0	6	6	4	53	
8:25 AM	0	2	5	3	0	3	7	5	0	0	12	5	0	3	8	1	54	
8:30 AM	0	1	8	2	0	4	4	4	0	1	4	5	0	3	5	3	44	
8:35 AM	0	3	10	4	0	2	2	1	0	0	4	3	0	4	5	3	41	
8:40 AM	0	0	5	1	0	6	0	4	0	1	2	3	0	2	9	2	35	
8:45 AM	0	4	8	1	0	3	3	2	0	0	10	0	0	5	11	2	49	
8:50 AM	0	2	4	1	0	5	3	5	0	2	11	5	0	5	5	4	52	
8:55 AM	0	2	7	3	0	1	4	3	0	1	10	2	0	7	8	1	49	
Count Total	0	84	223	43	0	64	82	95	0	28	193	121	0	139	184	52	1,308	
Peak Hour	0	52	131	21	0	37	61	58	0	21	115	85	0	83	97	29	790	

Traffic Counts - Heavy Vehicles, Bicycles on Road, and Pedestrians/Bicycles on Crosswalk

Interval Start Time	Heavy Vehicles					Interval Start Time	Bicycles on Roadway					Interval Start Time	Pedestrians/Bicycles on Crosswalk				
	EB	NB	WB	SB	Total		EB	NB	WB	SB	Total		EB	NB	WB	SB	Total
7:00 AM	0	0	0	0	0	7:00 AM	0	0	0	0	0	7:00 AM	0	0	0	1	1
7:05 AM	0	0	1	0	1	7:05 AM	0	0	0	1	1	7:05 AM	0	0	0	0	0
7:10 AM	0	0	0	0	0	7:10 AM	0	0	0	0	0	7:10 AM	0	0	0	0	0
7:15 AM	0	0	1	2	3	7:15 AM	0	0	0	0	0	7:15 AM	0	0	0	0	0
7:20 AM	0	0	1	1	2	7:20 AM	0	0	0	0	0	7:20 AM	0	0	0	0	0
7:25 AM	2	0	0	0	2	7:25 AM	0	0	0	0	0	7:25 AM	0	0	0	0	0
7:30 AM	0	0	0	0	0	7:30 AM	0	0	0	0	0	7:30 AM	0	0	0	0	0
7:35 AM	0	1	1	0	2	7:35 AM	0	0	0	0	0	7:35 AM	0	1	0	0	1
7:40 AM	1	1	0	0	2	7:40 AM	0	0	0	0	0	7:40 AM	0	0	0	0	0
7:45 AM	1	0	2	1	4	7:45 AM	1	0	0	0	1	7:45 AM	0	1	0	0	1
7:50 AM	1	0	0	1	2	7:50 AM	1	0	0	0	1	7:50 AM	0	0	0	0	0
7:55 AM	2	2	0	0	4	7:55 AM	0	0	0	0	0	7:55 AM	0	1	0	0	1
8:00 AM	1	1	2	0	4	8:00 AM	1	0	0	0	1	8:00 AM	0	0	0	2	2
8:05 AM	1	0	1	0	2	8:05 AM	0	0	0	0	0	8:05 AM	0	0	0	0	0
8:10 AM	0	2	0	1	3	8:10 AM	0	0	0	0	0	8:10 AM	0	0	0	0	0
8:15 AM	2	0	0	2	4	8:15 AM	0	0	0	0	0	8:15 AM	0	0	0	0	0
8:20 AM	1	1	0	1	3	8:20 AM	0	1	0	0	1	8:20 AM	0	0	0	0	0
8:25 AM	0	0	0	0	0	8:25 AM	0	0	0	0	0	8:25 AM	0	0	0	0	0
8:30 AM	0	0	0	0	0	8:30 AM	0	0	0	0	0	8:30 AM	0	0	0	0	0
8:35 AM	0	1	1	1	3	8:35 AM	0	0	0	0	0	8:35 AM	0	0	0	0	0
8:40 AM	0	2	2	0	4	8:40 AM	0	0	0	0	0	8:40 AM	0	2	0	0	2
8:45 AM	1	0	0	0	1	8:45 AM	0	0	0	1	1	8:45 AM	0	1	0	0	1
8:50 AM	0	1	1	0	2	8:50 AM	0	0	0	0	0	8:50 AM	0	0	0	0	0
8:55 AM	0	0	1	0	1	8:55 AM	0	0	0	0	0	8:55 AM	0	0	0	0	0
Count Total	13	12	14	10	49	Count Total	3	1	0	2	6	Count Total	0	6	0	3	9
Peak Hour	10	8	6	6	30	Peak Hour	3	1	0	0	4	Peak Hour	0	3	0	2	5



(303) 216-2439
www.alltrafficdata.net

Location: 4 NW HILL RD & SW FELLOWS ST AM
Date: Thursday, June 1, 2023
Peak Hour: 07:10 AM - 08:10 AM
Peak 15-Minutes: 07:45 AM - 08:00 AM

DRAFT

Peak Hour

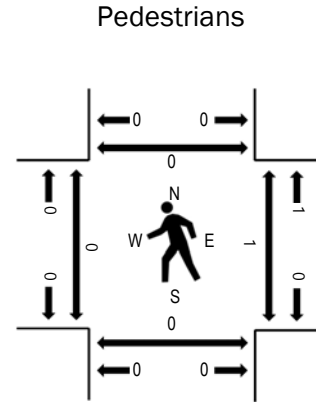
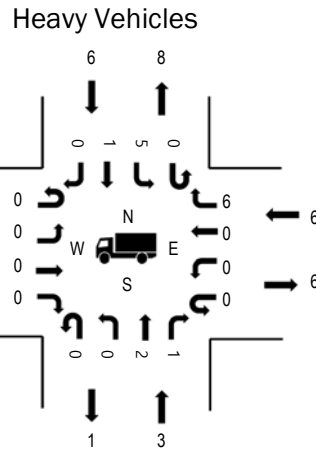
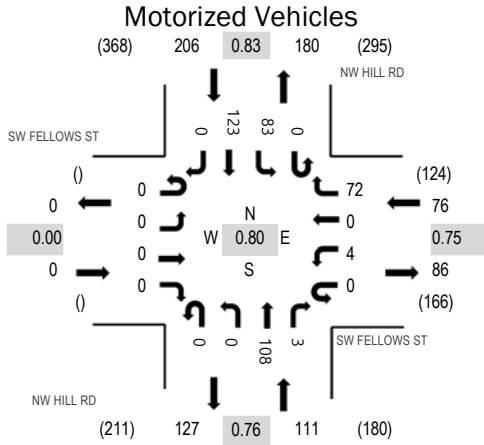

Note: Total study counts contained in parentheses.

	HV%	PHF
EB	0.0%	0.00
WB	7.9%	0.75
NB	2.7%	0.76
SB	2.9%	0.83
All	3.8%	0.80

Traffic Counts - Motorized Vehicles

Interval Start Time	SW FELLOWS ST Eastbound				SW FELLOWS ST Westbound				NW HILL RD Northbound				NW HILL RD Southbound				Total	Rolling Hour
	U-Turn	Left	Thru	Right	U-Turn	Left	Thru	Right	U-Turn	Left	Thru	Right	U-Turn	Left	Thru	Right		
7:00 AM	0	0	0	0	0	0	0	4	0	0	1	0	0	5	12	0	22	369
7:05 AM	0	0	0	0	0	0	0	0	0	0	4	1	0	6	6	0	17	380
7:10 AM	0	0	0	0	0	0	0	5	0	0	9	0	0	6	12	0	32	393
7:15 AM	0	0	0	0	0	0	0	7	0	0	4	0	0	6	7	0	24	381
7:20 AM	0	0	0	0	0	0	0	2	0	0	9	0	0	4	16	0	31	386
7:25 AM	0	0	0	0	0	0	0	2	0	0	3	0	0	10	6	0	21	377
7:30 AM	0	0	0	0	0	0	0	0	0	0	10	0	0	4	9	0	23	389
7:35 AM	0	0	0	0	0	0	0	10	0	0	8	1	0	6	11	0	36	389
7:40 AM	0	0	0	0	0	0	0	9	0	0	10	0	0	8	13	0	40	367
7:45 AM	0	0	0	0	0	1	0	6	0	0	11	1	0	9	9	0	37	347
7:50 AM	0	0	0	0	0	1	0	6	0	0	10	1	0	13	10	0	41	338
7:55 AM	0	0	0	0	0	0	0	14	0	0	15	0	0	10	6	0	45	325
8:00 AM	0	0	0	0	0	2	0	6	0	0	9	0	0	2	14	0	33	303
8:05 AM	0	0	0	0	0	0	0	5	0	0	10	0	0	5	10	0	30	
8:10 AM	0	0	0	0	0	0	0	4	0	0	4	0	0	7	5	0	20	
8:15 AM	0	0	0	0	0	1	0	5	0	0	12	0	0	5	6	0	29	
8:20 AM	0	0	0	0	0	0	0	5	0	0	6	0	0	4	7	0	22	
8:25 AM	0	0	0	0	0	0	0	11	0	0	7	0	0	6	9	0	33	
8:30 AM	0	0	0	0	0	0	0	1	0	0	6	0	0	8	8	0	23	
8:35 AM	0	0	0	0	0	0	0	2	0	0	2	0	0	7	3	0	14	
8:40 AM	0	0	0	0	0	0	0	4	0	0	2	0	0	9	5	0	20	
8:45 AM	0	0	0	0	0	0	0	4	0	0	5	0	0	7	12	0	28	
8:50 AM	0	0	0	0	0	0	0	4	0	0	11	0	0	8	5	0	28	
8:55 AM	0	0	0	0	0	0	0	3	0	0	8	0	0	7	5	0	23	
Count Total	0	0	0	0	0	5	0	119	0	0	176	4	0	162	206	0	672	
Peak Hour	0	0	0	0	0	4	0	72	0	0	108	3	0	83	123	0	393	

Traffic Counts - Heavy Vehicles, Bicycles on Road, and Pedestrians/Bicycles on Crosswalk

Interval Start Time	Heavy Vehicles					Interval Start Time	Bicycles on Roadway					Interval Start Time	Pedestrians/Bicycles on Crosswalk				
	EB	NB	WB	SB	Total		EB	NB	WB	SB	Total		EB	NB	WB	SB	Total
7:00 AM	0	0	0	0	0	7:00 AM	0	0	0	0	0	7:00 AM	0	0	0	0	0
7:05 AM	0	1	0	0	1	7:05 AM	0	0	0	0	0	7:05 AM	0	0	0	0	0
7:10 AM	0	1	0	0	1	7:10 AM	0	0	0	1	1	7:10 AM	0	0	0	0	0
7:15 AM	0	0	0	0	0	7:15 AM	0	0	0	0	0	7:15 AM	0	0	0	0	0
7:20 AM	0	0	1	2	3	7:20 AM	0	0	0	0	0	7:20 AM	0	0	0	0	0
7:25 AM	0	0	0	2	2	7:25 AM	0	0	0	0	0	7:25 AM	0	0	0	0	0
7:30 AM	0	0	0	0	0	7:30 AM	0	0	0	0	0	7:30 AM	0	0	0	0	0
7:35 AM	0	0	0	0	0	7:35 AM	0	0	0	0	0	7:35 AM	0	0	0	0	0
7:40 AM	0	0	1	0	1	7:40 AM	0	0	0	0	0	7:40 AM	0	0	0	0	0
7:45 AM	0	1	0	0	1	7:45 AM	0	0	0	1	1	7:45 AM	0	0	0	0	0
7:50 AM	0	0	1	1	2	7:50 AM	0	0	0	0	0	7:50 AM	0	0	0	0	0
7:55 AM	0	1	3	1	5	7:55 AM	0	0	0	0	0	7:55 AM	0	0	1	0	1
8:00 AM	0	0	0	0	0	8:00 AM	0	0	0	0	0	8:00 AM	0	0	0	0	0
8:05 AM	0	0	0	0	0	8:05 AM	0	0	0	0	0	8:05 AM	0	0	0	0	0
8:10 AM	0	0	0	1	1	8:10 AM	0	0	0	0	0	8:10 AM	0	0	0	0	0
8:15 AM	0	0	0	2	2	8:15 AM	0	1	0	0	1	8:15 AM	0	0	0	0	0
8:20 AM	0	0	1	0	1	8:20 AM	0	0	0	0	0	8:20 AM	0	0	0	0	0
8:25 AM	0	0	1	2	3	8:25 AM	0	0	0	0	0	8:25 AM	0	0	0	0	0
8:30 AM	0	0	0	0	0	8:30 AM	0	0	0	0	0	8:30 AM	0	0	0	0	0
8:35 AM	0	0	0	0	0	8:35 AM	0	0	0	0	0	8:35 AM	0	0	0	0	0
8:40 AM	0	0	2	0	2	8:40 AM	0	0	0	0	0	8:40 AM	0	0	0	0	0
8:45 AM	0	0	0	0	0	8:45 AM	0	0	0	1	1	8:45 AM	0	0	0	0	0
8:50 AM	0	0	0	0	0	8:50 AM	0	0	0	0	0	8:50 AM	0	0	0	0	0
8:55 AM	0	0	0	0	0	8:55 AM	0	0	0	0	0	8:55 AM	0	0	0	0	0
Count Total	0	4	10	11	25	Count Total	0	1	0	3	4	Count Total	0	0	1	0	1
Peak Hour	0	3	6	6	15	Peak Hour	0	0	0	2	2	Peak Hour	0	0	1	0	1



(303) 216-2439
www.alltrafficdata.net

Location: 5 NW HILL RD & NW FOX RIDGE RD AM

Date: Thursday, June 1, 2023

Peak Hour: 07:15 AM - 08:15 AM

Peak 15-Minutes: 07:45 AM - 08:00 AM

DRAFT

Peak Hour

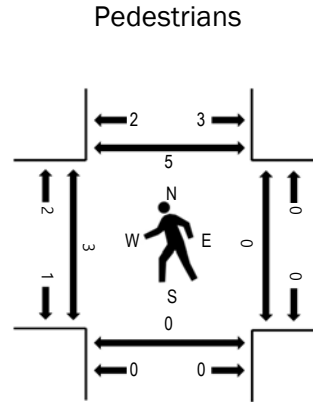
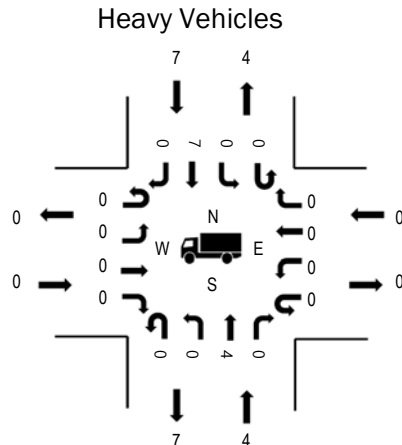
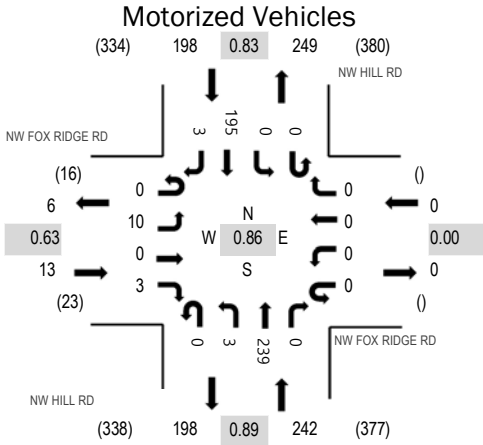

Note: Total study counts contained in parentheses.

	HV%	PHF
EB	0.0%	0.63
WB	0.0%	0.00
NB	1.7%	0.89
SB	3.5%	0.83
All	2.4%	0.86

Traffic Counts - Motorized Vehicles

Interval Start Time	NW FOX RIDGE RD Eastbound				NW FOX RIDGE RD Westbound				NW HILL RD Northbound				NW HILL RD Southbound				Total	Rolling Hour
	U-Turn	Left	Thru	Right	U-Turn	Left	Thru	Right	U-Turn	Left	Thru	Right	U-Turn	Left	Thru	Right		
7:00 AM	0	2	0	0	0	0	0	0	0	1	5	0	0	0	8	0	16	388
7:05 AM	0	0	0	0	0	0	0	0	0	0	14	0	0	0	10	0	24	412
7:10 AM	0	1	0	0	0	0	0	0	0	1	5	0	0	0	13	0	20	431
7:15 AM	0	2	0	0	0	0	0	0	0	0	16	0	0	0	15	0	33	453
7:20 AM	0	0	0	0	0	0	0	0	0	0	18	0	0	0	11	0	29	442
7:25 AM	0	1	0	0	0	0	0	0	0	0	14	0	0	0	10	0	25	444
7:30 AM	0	0	0	0	0	0	0	0	0	0	22	0	0	0	17	0	39	451
7:35 AM	0	0	0	0	0	0	0	0	0	0	20	0	0	0	12	0	32	433
7:40 AM	0	0	0	1	0	0	0	0	0	0	19	0	0	0	18	1	39	414
7:45 AM	0	0	0	1	0	0	0	0	0	1	19	0	0	0	21	0	42	393
7:50 AM	0	1	0	0	0	0	0	0	0	0	24	0	0	0	18	1	44	378
7:55 AM	0	1	0	0	0	0	0	0	0	0	24	0	0	0	20	0	45	361
8:00 AM	0	1	0	0	0	0	0	0	0	0	18	0	0	0	21	0	40	346
8:05 AM	0	2	0	1	0	0	0	0	0	1	22	0	0	0	16	1	43	
8:10 AM	0	2	0	0	0	0	0	0	0	1	23	0	0	0	16	0	42	
8:15 AM	0	0	0	1	0	0	0	0	0	0	10	0	0	0	11	0	22	
8:20 AM	0	1	0	2	0	0	0	0	0	2	11	0	0	0	15	0	31	
8:25 AM	0	0	0	0	0	0	0	0	0	3	17	0	0	0	12	0	32	
8:30 AM	0	0	0	0	0	0	0	0	0	1	10	0	0	0	10	0	21	
8:35 AM	0	0	0	0	0	0	0	0	0	0	5	0	0	0	8	0	13	
8:40 AM	0	1	0	0	0	0	0	0	0	0	5	0	0	0	12	0	18	
8:45 AM	0	0	0	0	0	0	0	0	0	0	10	0	0	0	17	0	27	
8:50 AM	0	0	0	1	0	0	0	0	0	0	18	0	0	0	8	0	27	
8:55 AM	0	0	0	1	0	0	0	0	0	1	16	0	0	0	11	1	30	
Count Total	0	15	0	8	0	0	0	0	0	12	365	0	0	0	330	4	734	
Peak Hour	0	10	0	3	0	0	0	0	0	3	239	0	0	0	195	3	453	

Traffic Counts - Heavy Vehicles, Bicycles on Road, and Pedestrians/Bicycles on Crosswalk

Interval Start Time	Heavy Vehicles					Interval Start Time	Bicycles on Roadway					Interval Start Time	Pedestrians/Bicycles on Crosswalk				
	EB	NB	WB	SB	Total		EB	NB	WB	SB	Total		EB	NB	WB	SB	Total
7:00 AM	0	0	0	0	0	7:00 AM	0	0	0	0	0	7:00 AM	0	0	0	0	0
7:05 AM	0	1	0	0	1	7:05 AM	0	0	0	1	1	7:05 AM	1	0	0	0	1
7:10 AM	0	0	0	0	0	7:10 AM	0	0	0	0	0	7:10 AM	0	0	0	2	2
7:15 AM	0	0	0	3	3	7:15 AM	0	0	0	0	0	7:15 AM	2	0	0	3	5
7:20 AM	0	0	0	0	0	7:20 AM	0	0	0	0	0	7:20 AM	0	0	0	0	0
7:25 AM	0	0	0	0	0	7:25 AM	0	0	0	0	0	7:25 AM	0	0	0	0	0
7:30 AM	0	0	0	0	0	7:30 AM	0	0	0	0	0	7:30 AM	0	0	0	0	0
7:35 AM	0	0	0	0	0	7:35 AM	0	0	0	0	0	7:35 AM	0	0	0	0	0
7:40 AM	0	0	0	0	0	7:40 AM	0	0	0	0	0	7:40 AM	0	0	0	0	0
7:45 AM	0	1	0	1	2	7:45 AM	0	0	0	0	0	7:45 AM	0	0	0	0	0
7:50 AM	0	1	0	1	2	7:50 AM	0	0	0	0	0	7:50 AM	1	0	0	1	2
7:55 AM	0	0	0	0	0	7:55 AM	0	0	0	0	0	7:55 AM	0	0	0	0	0
8:00 AM	0	2	0	0	2	8:00 AM	0	0	0	0	0	8:00 AM	0	0	0	0	0
8:05 AM	0	0	0	0	0	8:05 AM	0	0	0	0	0	8:05 AM	0	0	0	1	1
8:10 AM	0	0	0	2	2	8:10 AM	0	0	0	0	0	8:10 AM	0	0	0	0	0
8:15 AM	0	0	0	1	1	8:15 AM	0	0	0	0	0	8:15 AM	0	0	0	0	0
8:20 AM	0	1	0	1	2	8:20 AM	0	0	0	0	0	8:20 AM	0	0	0	0	0
8:25 AM	0	0	0	0	0	8:25 AM	0	0	0	0	0	8:25 AM	0	0	0	0	0
8:30 AM	0	0	0	0	0	8:30 AM	0	0	0	0	0	8:30 AM	0	0	0	1	1
8:35 AM	0	0	0	1	1	8:35 AM	0	0	0	0	0	8:35 AM	0	0	0	0	0
8:40 AM	0	0	0	0	0	8:40 AM	0	0	0	0	0	8:40 AM	2	0	0	2	4
8:45 AM	0	0	0	0	0	8:45 AM	0	0	0	1	1	8:45 AM	2	0	0	0	2
8:50 AM	0	1	0	0	1	8:50 AM	0	0	0	0	0	8:50 AM	0	0	0	0	0
8:55 AM	0	0	0	0	0	8:55 AM	0	0	0	0	0	8:55 AM	0	0	0	0	0
Count Total	0	7	0	10	17	Count Total	0	0	0	2	2	Count Total	8	0	0	10	18
Peak Hour	0	4	0	7	11	Peak Hour	0	0	0	0	0	Peak Hour	3	0	0	5	8



(303) 216-2439
www.alltrafficdata.net

Location: 1 NW HILL RD & NW BAKER CREEK RD PM

Date: Thursday, June 1, 2023

Peak Hour: 04:30 PM - 05:30 PM

Peak 15-Minutes: 04:45 PM - 05:00 PM

DRAFT

Peak Hour

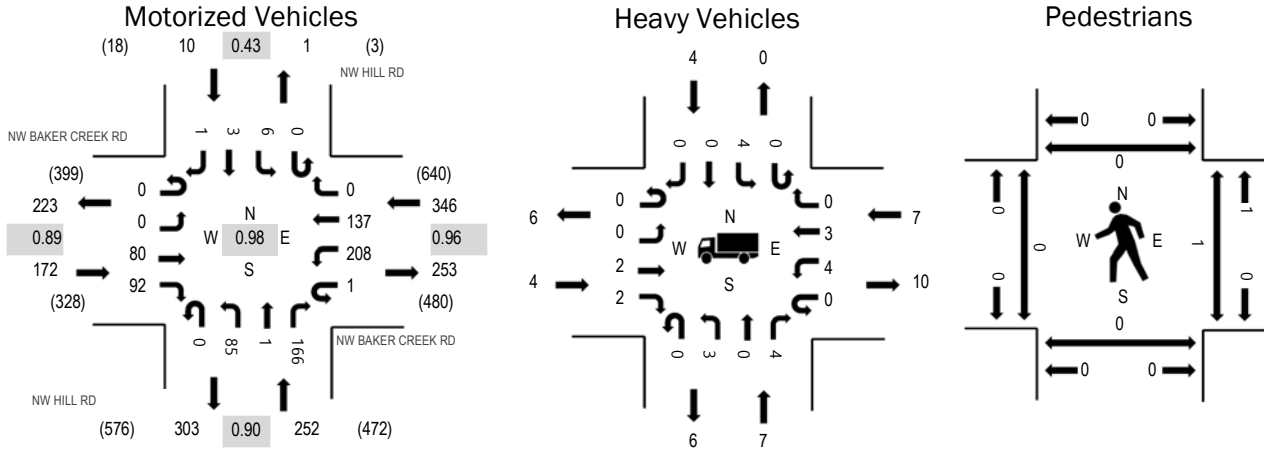

Note: Total study counts contained in parentheses.

	HV%	PHF
EB	2.3%	0.89
WB	2.0%	0.96
NB	2.8%	0.90
SB	40.0%	0.43
All	2.8%	0.98

Traffic Counts - Motorized Vehicles

Interval Start Time	NW BAKER CREEK RD Eastbound				NW BAKER CREEK RD Westbound				NW HILL RD Northbound				NW HILL RD Southbound				Total	Rolling Hour
	U-Turn	Left	Thru	Right	U-Turn	Left	Thru	Right	U-Turn	Left	Thru	Right	U-Turn	Left	Thru	Right		
4:00 PM	0	0	7	6	0	19	11	0	0	6	0	13	0	2	1	0	65	762
4:05 PM	0	0	3	9	0	17	8	0	0	9	0	15	0	0	1	1	63	759
4:10 PM	0	0	13	6	0	20	7	0	0	9	0	10	0	0	0	0	65	760
4:15 PM	0	0	7	8	0	16	6	0	0	7	0	11	0	0	0	0	55	755
4:20 PM	0	0	6	5	0	19	8	0	0	6	0	21	0	1	0	0	66	750
4:25 PM	0	0	6	5	0	12	7	1	0	6	0	10	0	0	0	2	49	753
4:30 PM	0	0	7	7	0	22	12	0	0	9	0	13	0	0	0	0	70	780
4:35 PM	0	0	9	6	0	20	11	0	0	7	0	12	0	0	1	0	66	764
4:40 PM	0	0	4	15	0	14	6	0	0	4	0	20	0	0	0	0	63	747
4:45 PM	0	0	8	6	0	17	15	0	0	7	0	11	0	0	0	0	64	740
4:50 PM	0	0	4	9	0	14	10	0	0	12	0	17	0	1	0	0	67	728
4:55 PM	0	0	12	6	0	18	13	0	0	4	0	16	0	0	0	0	69	726
5:00 PM	0	0	5	8	0	14	16	0	0	8	0	11	0	0	0	0	62	696
5:05 PM	0	0	11	9	0	15	9	0	0	6	1	10	0	1	1	1	64	
5:10 PM	0	0	5	6	0	20	10	0	0	7	0	11	0	1	0	0	60	
5:15 PM	0	0	6	3	1	15	6	0	0	2	0	14	0	3	0	0	50	
5:20 PM	0	0	6	11	0	17	11	0	0	8	0	16	0	0	0	0	69	
5:25 PM	0	0	3	6	0	22	18	0	0	11	0	15	0	0	1	0	76	
5:30 PM	0	0	10	10	0	15	3	0	0	4	0	12	0	0	0	0	54	
5:35 PM	0	0	5	3	0	21	6	0	0	4	0	10	0	0	0	0	49	
5:40 PM	0	0	4	2	0	14	11	0	0	11	1	13	0	0	0	0	56	
5:45 PM	0	0	6	8	0	15	9	0	0	6	0	8	0	0	0	0	52	
5:50 PM	0	0	9	8	0	18	12	0	0	6	0	12	0	0	0	0	65	
5:55 PM	0	0	6	4	0	11	8	0	0	3	0	7	0	0	0	0	39	
Count Total	0	0	162	166	1	405	233	1	0	162	2	308	0	9	5	4	1,458	
Peak Hour	0	0	80	92	1	208	137	0	0	85	1	166	0	6	3	1	780	

Traffic Counts - Heavy Vehicles, Bicycles on Road, and Pedestrians/Bicycles on Crosswalk

Interval Start Time	Heavy Vehicles					Interval Start Time	Bicycles on Roadway					Interval Start Time	Pedestrians/Bicycles on Crosswalk				
	EB	NB	WB	SB	Total		EB	NB	WB	SB	Total		EB	NB	WB	SB	Total
4:00 PM	0	0	1	0	1	4:00 PM	0	0	0	0	0	4:00 PM	0	0	0	0	0
4:05 PM	0	1	0	1	2	4:05 PM	0	0	0	0	0	4:05 PM	0	0	0	0	0
4:10 PM	2	1	1	0	4	4:10 PM	0	0	0	0	0	4:10 PM	0	0	0	0	0
4:15 PM	0	0	1	0	1	4:15 PM	0	0	0	0	0	4:15 PM	0	0	0	0	0
4:20 PM	0	1	0	0	1	4:20 PM	0	0	1	0	1	4:20 PM	0	0	0	0	0
4:25 PM	1	0	1	0	2	4:25 PM	0	0	0	0	0	4:25 PM	0	0	0	0	0
4:30 PM	0	2	2	0	4	4:30 PM	0	0	0	0	0	4:30 PM	0	0	0	0	0
4:35 PM	1	1	0	0	2	4:35 PM	0	0	0	0	0	4:35 PM	0	0	0	0	0
4:40 PM	1	1	0	0	2	4:40 PM	0	0	0	0	0	4:40 PM	0	0	0	0	0
4:45 PM	0	0	2	0	2	4:45 PM	0	0	0	0	0	4:45 PM	0	0	0	0	0
4:50 PM	1	1	1	0	3	4:50 PM	0	0	0	0	0	4:50 PM	0	0	0	0	0
4:55 PM	1	0	0	0	1	4:55 PM	0	0	0	0	0	4:55 PM	0	0	0	0	0
5:00 PM	0	0	0	0	0	5:00 PM	0	0	0	0	0	5:00 PM	0	0	0	0	0
5:05 PM	0	0	0	0	0	5:05 PM	0	0	0	0	0	5:05 PM	0	0	0	0	0
5:10 PM	0	0	1	1	2	5:10 PM	0	0	0	0	0	5:10 PM	0	0	1	0	1
5:15 PM	0	0	0	3	3	5:15 PM	0	0	0	0	0	5:15 PM	0	0	0	0	0
5:20 PM	0	1	0	0	1	5:20 PM	0	0	0	0	0	5:20 PM	0	0	0	0	0
5:25 PM	0	1	1	0	2	5:25 PM	0	0	0	0	0	5:25 PM	0	0	0	0	0
5:30 PM	0	0	0	0	0	5:30 PM	0	0	0	0	0	5:30 PM	0	0	0	0	0
5:35 PM	1	0	1	0	2	5:35 PM	0	0	0	0	0	5:35 PM	0	0	0	0	0
5:40 PM	0	0	1	0	1	5:40 PM	0	0	0	0	0	5:40 PM	0	0	0	0	0
5:45 PM	1	0	1	0	2	5:45 PM	0	0	0	0	0	5:45 PM	0	0	0	0	0
5:50 PM	0	0	0	0	0	5:50 PM	0	0	0	0	0	5:50 PM	0	0	0	0	0
5:55 PM	0	0	0	0	0	5:55 PM	0	1	0	0	1	5:55 PM	0	0	0	0	0
Count Total	9	10	14	5	38	Count Total	0	1	1	0	2	Count Total	0	0	1	0	1
Peak Hour	4	7	7	4	22	Peak Hour	0	0	0	0	0	Peak Hour	0	0	1	0	1



(303) 216-2439
www.alltrafficdata.net

Location: 2 NW HILL RD & NW WALLACE RD PM

Date: Thursday, June 1, 2023

Peak Hour: 04:35 PM - 05:35 PM

Peak 15-Minutes: 05:20 PM - 05:35 PM

DRAFT

Peak Hour

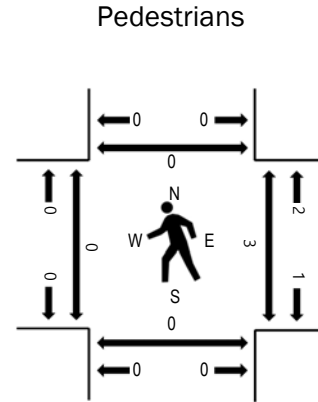
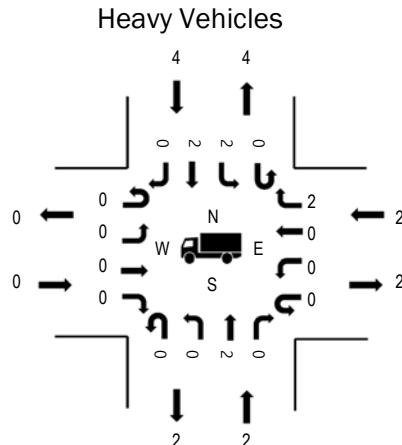
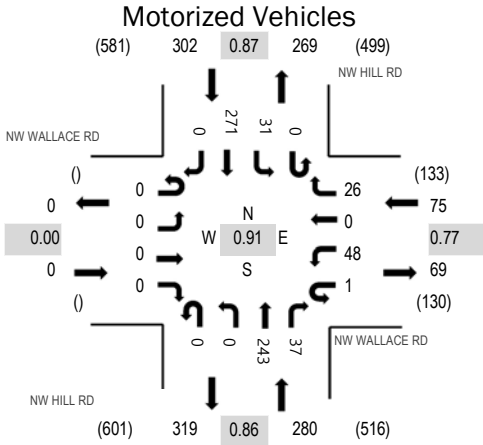

Note: Total study counts contained in parentheses.

	HV%	PHF
EB	0.0%	0.00
WB	2.7%	0.77
NB	0.7%	0.86
SB	1.3%	0.87
All	1.2%	0.91

Traffic Counts - Motorized Vehicles

Interval Start Time	NW WALLACE RD Eastbound				NW WALLACE RD Westbound				NW HILL RD Northbound				NW HILL RD Southbound				Total	Rolling Hour
	U-Turn	Left	Thru	Right	U-Turn	Left	Thru	Right	U-Turn	Left	Thru	Right	U-Turn	Left	Thru	Right		
4:00 PM	0	0	0	0	0	0	0	1	0	0	17	5	1	3	15	0	42	624
4:05 PM	0	0	0	0	0	4	0	3	0	0	23	1	0	3	19	0	53	640
4:10 PM	0	0	0	0	0	4	0	0	0	0	20	1	0	5	24	0	54	645
4:15 PM	0	0	0	0	0	8	0	4	0	0	15	3	0	3	21	0	54	643
4:20 PM	0	0	0	0	0	2	0	2	0	0	22	2	0	2	26	0	56	632
4:25 PM	0	0	0	0	0	3	0	2	0	0	15	4	0	1	17	0	42	635
4:30 PM	0	0	0	0	0	3	0	5	0	0	18	3	0	1	27	0	57	655
4:35 PM	0	0	0	0	0	3	0	3	0	0	17	2	0	3	24	0	52	657
4:40 PM	0	0	0	0	0	2	0	2	0	0	24	1	0	4	28	0	61	646
4:45 PM	0	0	0	0	0	5	0	3	0	0	14	4	0	1	20	0	47	631
4:50 PM	0	0	0	0	0	2	0	3	0	0	30	4	0	3	14	0	56	623
4:55 PM	0	0	0	0	0	2	0	0	0	0	20	3	0	1	24	0	50	624
5:00 PM	0	0	0	0	0	4	0	4	0	0	20	5	0	2	23	0	58	606
5:05 PM	0	0	0	0	0	6	0	3	0	0	15	5	0	5	24	0	58	
5:10 PM	0	0	0	0	1	5	0	3	0	0	15	2	0	3	23	0	52	
5:15 PM	0	0	0	0	0	3	0	0	0	0	19	1	0	1	19	0	43	
5:20 PM	0	0	0	0	0	5	0	1	0	0	25	2	0	2	24	0	59	
5:25 PM	0	0	0	0	0	3	0	2	0	0	26	4	0	2	25	0	62	
5:30 PM	0	0	0	0	0	8	0	2	0	0	18	4	0	4	23	0	59	
5:35 PM	0	0	0	0	0	0	0	0	0	0	17	3	0	3	18	0	41	
5:40 PM	0	0	0	0	0	1	0	3	0	0	22	2	0	1	17	0	46	
5:45 PM	0	0	0	0	0	5	0	2	0	0	10	1	0	3	18	0	39	
5:50 PM	0	0	0	0	0	5	0	1	0	0	18	1	0	6	26	0	57	
5:55 PM	0	0	0	0	0	0	0	0	0	0	9	4	0	0	19	0	32	
Count Total	0	0	0	0	1	83	0	49	0	0	449	67	1	62	518	0	1,230	
Peak Hour	0	0	0	0	1	48	0	26	0	0	243	37	0	31	271	0	657	

Traffic Counts - Heavy Vehicles, Bicycles on Road, and Pedestrians/Bicycles on Crosswalk

Interval Start Time	Heavy Vehicles					Interval Start Time	Bicycles on Roadway					Interval Start Time	Pedestrians/Bicycles on Crosswalk				
	EB	NB	WB	SB	Total		EB	NB	WB	SB	Total		EB	NB	WB	SB	Total
4:00 PM	0	1	0	1	2	4:00 PM	0	0	0	0	0	4:00 PM	0	0	0	0	0
4:05 PM	0	0	0	1	1	4:05 PM	0	0	0	0	0	4:05 PM	0	0	0	0	0
4:10 PM	0	0	0	1	1	4:10 PM	0	0	0	0	0	4:10 PM	0	0	0	0	0
4:15 PM	0	0	0	1	1	4:15 PM	0	0	0	0	0	4:15 PM	0	0	0	0	0
4:20 PM	0	0	0	0	0	4:20 PM	0	0	0	0	0	4:20 PM	0	0	0	0	0
4:25 PM	0	0	1	0	1	4:25 PM	0	0	0	0	0	4:25 PM	0	0	0	0	0
4:30 PM	0	1	1	1	3	4:30 PM	0	0	0	0	0	4:30 PM	0	0	0	0	0
4:35 PM	0	1	0	0	1	4:35 PM	0	0	0	0	0	4:35 PM	0	0	0	0	0
4:40 PM	0	0	1	1	2	4:40 PM	0	0	0	0	0	4:40 PM	0	0	0	0	0
4:45 PM	0	0	0	1	1	4:45 PM	0	0	0	0	0	4:45 PM	0	0	0	0	0
4:50 PM	0	0	1	0	1	4:50 PM	0	0	0	0	0	4:50 PM	0	0	0	0	0
4:55 PM	0	0	0	1	1	4:55 PM	0	0	0	0	0	4:55 PM	0	0	1	0	1
5:00 PM	0	0	0	0	0	5:00 PM	0	0	0	0	0	5:00 PM	0	0	0	0	0
5:05 PM	0	0	0	0	0	5:05 PM	0	0	0	0	0	5:05 PM	0	0	0	0	0
5:10 PM	0	0	0	1	1	5:10 PM	0	0	0	0	0	5:10 PM	0	0	1	0	1
5:15 PM	0	0	0	0	0	5:15 PM	0	0	0	0	0	5:15 PM	0	0	0	0	0
5:20 PM	0	0	0	0	0	5:20 PM	0	2	0	0	2	5:20 PM	0	0	0	0	0
5:25 PM	0	1	0	0	1	5:25 PM	0	0	0	0	0	5:25 PM	0	0	1	0	1
5:30 PM	0	0	0	0	0	5:30 PM	0	0	0	0	0	5:30 PM	0	0	0	0	0
5:35 PM	0	0	0	1	1	5:35 PM	0	0	0	0	0	5:35 PM	0	0	0	0	0
5:40 PM	0	0	0	0	0	5:40 PM	0	0	0	0	0	5:40 PM	0	0	0	0	0
5:45 PM	0	0	1	1	2	5:45 PM	0	0	0	0	0	5:45 PM	0	0	0	0	0
5:50 PM	0	0	0	1	1	5:50 PM	0	0	0	0	0	5:50 PM	0	0	0	0	0
5:55 PM	0	0	0	0	0	5:55 PM	0	0	0	0	0	5:55 PM	0	0	0	0	0
Count Total	0	4	5	12	21	Count Total	0	2	0	0	2	Count Total	0	0	3	0	3
Peak Hour	0	2	2	4	8	Peak Hour	0	2	0	0	2	Peak Hour	0	0	3	0	3



(303) 216-2439
www.alltrafficdata.net

Location: 3 NW HILL RD & SW 2ND ST PM
Date: Thursday, June 1, 2023
Peak Hour: 04:30 PM - 05:30 PM
Peak 15-Minutes: 05:10 PM - 05:25 PM

DRAFT

Peak Hour

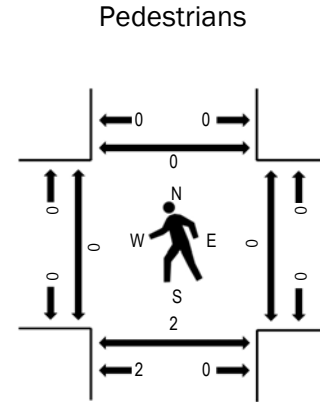
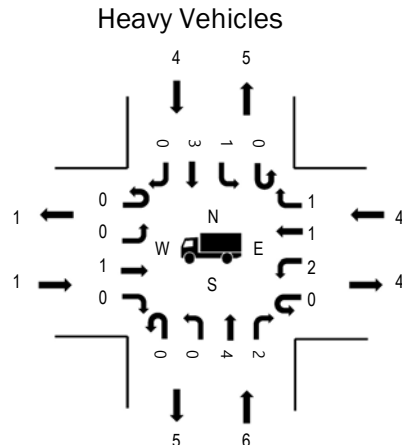
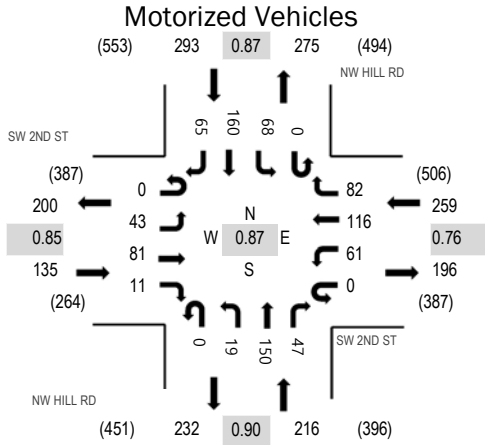

Note: Total study counts contained in parentheses.

	HV%	PHF
EB	0.7%	0.85
WB	1.5%	0.76
NB	2.8%	0.90
SB	1.4%	0.87
All	1.7%	0.87

Traffic Counts - Motorized Vehicles

Interval Start Time	SW 2ND ST Eastbound				SW 2ND ST Westbound				NW HILL RD Northbound			NW HILL RD Southbound				Total	Rolling Hour	
	U-Turn	Left	Thru	Right	U-Turn	Left	Thru	Right	U-Turn	Left	Thru	Right	U-Turn	Left	Thru			Right
4:00 PM	0	4	6	4	0	5	12	2	0	1	13	6	0	3	10	2	68	859
4:05 PM	0	2	6	3	0	5	7	7	0	1	13	0	0	7	10	3	64	858
4:10 PM	0	1	6	1	0	5	11	8	0	3	10	5	0	6	14	7	77	862
4:15 PM	0	4	7	3	0	2	6	10	0	1	11	6	0	9	14	5	78	874
4:20 PM	0	3	9	1	0	7	13	8	0	3	6	4	0	6	13	4	77	884
4:25 PM	0	2	5	2	0	2	8	5	0	2	13	5	0	4	8	5	61	890
4:30 PM	0	2	4	1	0	7	12	7	0	2	11	7	0	5	12	4	74	903
4:35 PM	0	1	4	1	0	9	9	6	0	0	13	5	0	3	19	9	79	899
4:40 PM	0	6	7	1	0	5	12	3	0	3	12	7	0	3	19	10	88	899
4:45 PM	0	3	4	1	0	3	5	7	0	0	7	4	0	4	8	6	52	861
4:50 PM	0	1	9	0	0	5	4	8	0	1	17	3	0	2	8	5	63	874
4:55 PM	0	5	6	3	0	4	7	7	0	4	15	2	0	5	14	6	78	870
5:00 PM	0	0	11	2	0	3	6	7	0	1	14	2	0	6	13	2	67	860
5:05 PM	0	4	7	0	0	5	9	3	0	2	10	2	0	8	12	6	68	
5:10 PM	0	1	8	0	0	5	21	10	0	1	13	3	0	10	14	3	89	
5:15 PM	0	6	8	1	0	6	15	7	0	3	11	3	0	9	14	5	88	
5:20 PM	0	6	6	0	0	5	8	9	0	0	13	6	0	7	18	5	83	
5:25 PM	0	8	7	1	0	4	8	8	0	2	14	3	0	6	9	4	74	
5:30 PM	0	2	5	1	0	6	14	0	0	3	10	5	0	8	12	4	70	
5:35 PM	0	8	8	1	0	10	14	5	0	1	7	2	0	4	16	3	79	
5:40 PM	0	2	1	0	0	2	8	7	0	2	11	3	0	3	9	2	50	
5:45 PM	0	5	3	1	0	9	10	4	0	1	8	3	0	6	10	5	65	
5:50 PM	0	2	9	0	0	2	3	8	0	1	4	7	0	8	11	4	59	
5:55 PM	0	5	7	0	0	8	10	4	0	1	5	3	0	6	12	7	68	
Count Total	0	83	153	28	0	124	232	150	0	39	261	96	0	138	299	116	1,719	
Peak Hour	0	43	81	11	0	61	116	82	0	19	150	47	0	68	160	65	903	

Traffic Counts - Heavy Vehicles, Bicycles on Road, and Pedestrians/Bicycles on Crosswalk

Interval Start Time	Heavy Vehicles					Interval Start Time	Bicycles on Roadway					Interval Start Time	Pedestrians/Bicycles on Crosswalk				
	EB	NB	WB	SB	Total		EB	NB	WB	SB	Total		EB	NB	WB	SB	Total
4:00 PM	2	1	1	1	5	4:00 PM	0	0	0	0	0	4:00 PM	0	1	0	0	1
4:05 PM	0	0	1	0	1	4:05 PM	0	0	0	0	0	4:05 PM	0	0	0	0	0
4:10 PM	0	1	0	0	1	4:10 PM	0	0	0	0	0	4:10 PM	0	0	0	0	0
4:15 PM	0	0	0	1	1	4:15 PM	0	0	0	0	0	4:15 PM	0	0	0	0	0
4:20 PM	0	0	0	0	0	4:20 PM	0	0	0	0	0	4:20 PM	0	1	0	0	1
4:25 PM	1	0	0	0	1	4:25 PM	0	0	0	0	0	4:25 PM	0	0	0	0	0
4:30 PM	0	1	2	1	4	4:30 PM	0	0	0	0	0	4:30 PM	0	0	0	0	0
4:35 PM	0	1	0	1	2	4:35 PM	0	0	0	0	0	4:35 PM	0	0	0	0	0
4:40 PM	0	0	0	0	0	4:40 PM	1	0	0	0	1	4:40 PM	0	3	0	0	3
4:45 PM	0	0	1	1	2	4:45 PM	0	0	0	0	0	4:45 PM	0	0	0	0	0
4:50 PM	1	0	0	0	1	4:50 PM	0	0	0	0	0	4:50 PM	0	1	0	0	1
4:55 PM	0	1	0	1	2	4:55 PM	0	0	0	0	0	4:55 PM	0	1	0	0	1
5:00 PM	0	0	0	0	0	5:00 PM	0	0	0	0	0	5:00 PM	0	0	0	0	0
5:05 PM	0	0	0	0	0	5:05 PM	0	0	0	0	0	5:05 PM	0	0	0	0	0
5:10 PM	0	1	0	0	1	5:10 PM	0	0	0	0	0	5:10 PM	0	0	0	0	0
5:15 PM	0	0	1	0	1	5:15 PM	0	0	0	0	0	5:15 PM	0	0	0	1	1
5:20 PM	0	2	0	0	2	5:20 PM	0	0	0	0	0	5:20 PM	0	0	0	0	0
5:25 PM	0	0	0	0	0	5:25 PM	0	0	0	0	0	5:25 PM	1	0	0	1	2
5:30 PM	0	0	0	0	0	5:30 PM	0	0	0	0	0	5:30 PM	0	0	0	0	0
5:35 PM	0	0	0	0	0	5:35 PM	0	0	0	0	0	5:35 PM	0	0	0	0	0
5:40 PM	0	0	0	1	1	5:40 PM	0	0	0	0	0	5:40 PM	0	0	0	0	0
5:45 PM	0	0	2	1	3	5:45 PM	0	0	0	0	0	5:45 PM	0	0	0	0	0
5:50 PM	2	0	0	1	3	5:50 PM	0	0	0	0	0	5:50 PM	0	0	0	0	0
5:55 PM	0	1	1	0	2	5:55 PM	0	0	0	0	0	5:55 PM	0	0	0	0	0
Count Total	6	9	9	9	33	Count Total	1	0	0	0	1	Count Total	1	7	0	2	10
Peak Hour	1	6	4	4	15	Peak Hour	1	0	0	0	1	Peak Hour	1	5	0	2	8



(303) 216-2439
www.alltrafficdata.net

Location: 4 NW HILL RD & SW FELLOWS ST PM
Date: Thursday, June 1, 2023
Peak Hour: 04:20 PM - 05:20 PM
Peak 15-Minutes: 05:05 PM - 05:20 PM

DRAFT

Peak Hour

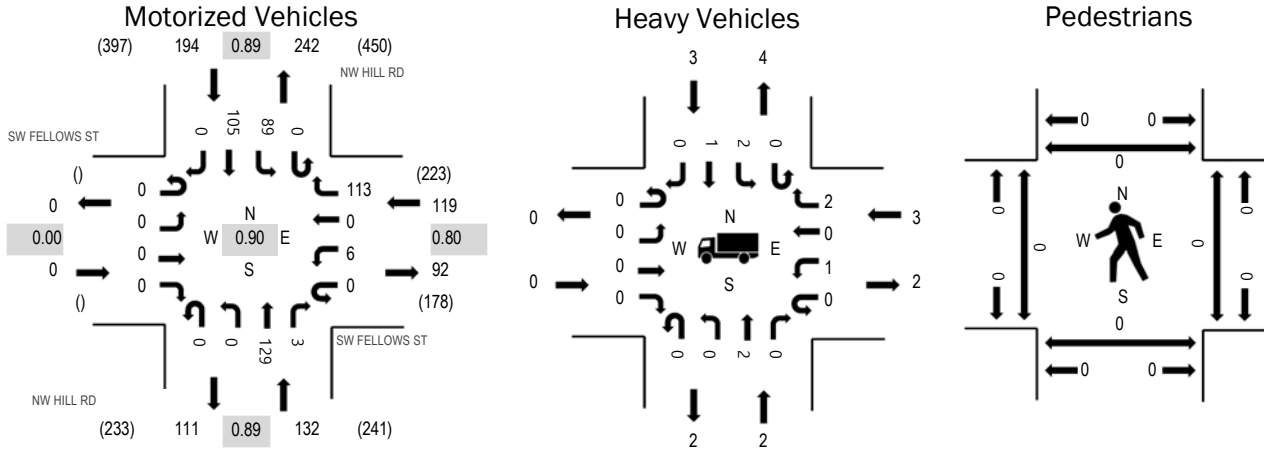

Note: Total study counts contained in parentheses.

	HV%	PHF
EB	0.0%	0.00
WB	2.5%	0.80
NB	1.5%	0.89
SB	1.5%	0.89
All	1.8%	0.90

Traffic Counts - Motorized Vehicles

Interval Start Time	SW FELLOWS ST Eastbound				SW FELLOWS ST Westbound				NW HILL RD Northbound				NW HILL RD Southbound				Total	Rolling Hour
	U-Turn	Left	Thru	Right	U-Turn	Left	Thru	Right	U-Turn	Left	Thru	Right	U-Turn	Left	Thru	Right		
4:00 PM	0	0	0	0	0	0	0	10	0	0	13	1	0	11	5	0	40	435
4:05 PM	0	0	0	0	0	0	0	10	0	0	5	0	0	8	12	0	35	429
4:10 PM	0	0	0	0	0	0	0	12	0	0	7	1	0	7	8	0	35	434
4:15 PM	0	0	0	0	0	1	0	5	0	0	12	0	0	10	9	0	37	441
4:20 PM	0	0	0	0	0	0	0	14	0	0	7	0	0	7	16	0	44	445
4:25 PM	0	0	0	0	0	0	0	6	0	0	13	0	0	4	10	0	33	432
4:30 PM	0	0	0	0	0	0	0	10	0	0	11	1	0	4	5	0	31	428
4:35 PM	0	0	0	0	0	1	0	7	0	0	12	0	0	7	11	0	38	436
4:40 PM	0	0	0	0	0	0	0	5	0	0	13	0	0	9	13	0	40	435
4:45 PM	0	0	0	0	0	2	0	6	0	0	8	1	0	5	8	0	30	429
4:50 PM	0	0	0	0	0	1	0	14	0	0	10	0	0	8	5	0	38	430
4:55 PM	0	0	0	0	0	0	0	9	0	0	12	0	0	4	9	0	34	426
5:00 PM	0	0	0	0	0	1	0	10	0	0	8	0	0	8	7	0	34	426
5:05 PM	0	0	0	0	0	1	0	11	0	0	10	0	0	7	11	0	40	445
5:10 PM	0	0	0	0	0	0	0	14	0	0	12	1	0	11	4	0	42	445
5:15 PM	0	0	0	0	0	0	0	7	0	0	13	0	0	15	6	0	41	445
5:20 PM	0	0	0	0	0	0	0	9	0	0	7	0	0	6	9	0	31	445
5:25 PM	0	0	0	0	0	0	0	5	0	0	11	0	0	5	8	0	29	445
5:30 PM	0	0	0	0	0	0	0	10	0	0	11	0	0	8	10	0	39	445
5:35 PM	0	0	0	0	0	0	0	8	0	0	7	0	0	6	16	0	37	445
5:40 PM	0	0	0	0	0	0	0	7	0	0	9	1	0	8	9	0	34	445
5:45 PM	0	0	0	0	0	0	0	6	0	0	10	0	0	4	11	0	31	445
5:50 PM	0	0	0	0	0	0	0	11	0	0	8	0	0	3	12	0	34	445
5:55 PM	0	0	0	0	0	0	0	10	0	0	5	1	0	6	12	0	34	445
Count Total	0	0	0	0	0	7	0	216	0	0	234	7	0	171	226	0	861	
Peak Hour	0	0	0	0	0	6	0	113	0	0	129	3	0	89	105	0	445	

Traffic Counts - Heavy Vehicles, Bicycles on Road, and Pedestrians/Bicycles on Crosswalk

Interval Start Time	Heavy Vehicles					Interval Start Time	Bicycles on Roadway					Interval Start Time	Pedestrians/Bicycles on Crosswalk				
	EB	NB	WB	SB	Total		EB	NB	WB	SB	Total		EB	NB	WB	SB	Total
4:00 PM	0	0	0	1	1	4:00 PM	0	0	0	0	0	4:00 PM	0	0	0	0	0
4:05 PM	0	0	0	1	1	4:05 PM	0	0	0	0	0	4:05 PM	0	0	0	0	0
4:10 PM	0	0	0	0	0	4:10 PM	0	0	0	0	0	4:10 PM	0	0	0	0	0
4:15 PM	0	0	2	1	3	4:15 PM	0	0	0	0	0	4:15 PM	0	0	0	0	0
4:20 PM	0	0	0	1	1	4:20 PM	0	0	0	0	0	4:20 PM	0	0	0	0	0
4:25 PM	0	0	0	1	1	4:25 PM	0	0	0	0	0	4:25 PM	0	0	0	0	0
4:30 PM	0	0	0	0	0	4:30 PM	0	0	0	0	0	4:30 PM	0	0	0	0	0
4:35 PM	0	0	0	0	0	4:35 PM	0	0	0	0	0	4:35 PM	0	0	0	0	0
4:40 PM	0	0	0	0	0	4:40 PM	0	0	0	1	1	4:40 PM	0	0	0	0	0
4:45 PM	0	0	0	0	0	4:45 PM	0	0	0	0	0	4:45 PM	0	0	0	0	0
4:50 PM	0	0	2	0	2	4:50 PM	0	0	0	0	0	4:50 PM	0	0	0	0	0
4:55 PM	0	0	0	1	1	4:55 PM	0	0	0	0	0	4:55 PM	0	0	0	0	0
5:00 PM	0	0	0	0	0	5:00 PM	0	0	0	0	0	5:00 PM	0	0	0	0	0
5:05 PM	0	0	0	0	0	5:05 PM	0	0	0	0	0	5:05 PM	0	0	0	0	0
5:10 PM	0	2	0	0	2	5:10 PM	0	0	0	0	0	5:10 PM	0	0	0	0	0
5:15 PM	0	0	1	0	1	5:15 PM	0	0	0	0	0	5:15 PM	0	0	0	0	0
5:20 PM	0	0	0	0	0	5:20 PM	0	0	0	1	1	5:20 PM	0	0	0	0	0
5:25 PM	0	1	0	0	1	5:25 PM	0	0	0	0	0	5:25 PM	0	0	0	0	0
5:30 PM	0	0	0	0	0	5:30 PM	0	0	0	0	0	5:30 PM	0	0	0	0	0
5:35 PM	0	0	0	0	0	5:35 PM	0	0	0	0	0	5:35 PM	0	0	0	0	0
5:40 PM	0	0	0	1	1	5:40 PM	0	0	0	0	0	5:40 PM	0	0	0	0	0
5:45 PM	0	1	0	1	2	5:45 PM	0	0	0	0	0	5:45 PM	0	0	0	0	0
5:50 PM	0	0	0	0	0	5:50 PM	0	0	0	0	0	5:50 PM	0	0	0	0	0
5:55 PM	0	0	0	0	0	5:55 PM	0	0	0	0	0	5:55 PM	0	0	0	0	0
Count Total	0	4	5	8	17	Count Total	0	0	0	2	2	Count Total	0	0	0	0	0
Peak Hour	0	2	3	3	8	Peak Hour	0	0	0	1	1	Peak Hour	0	0	0	0	0



(303) 216-2439
www.alltrafficdata.net

Location: 5 NW HILL RD & NW FOX RIDGE RD PM

Date: Thursday, June 1, 2023

Peak Hour: 04:35 PM - 05:35 PM

Peak 15-Minutes: 05:20 PM - 05:35 PM

DRAFT

Peak Hour

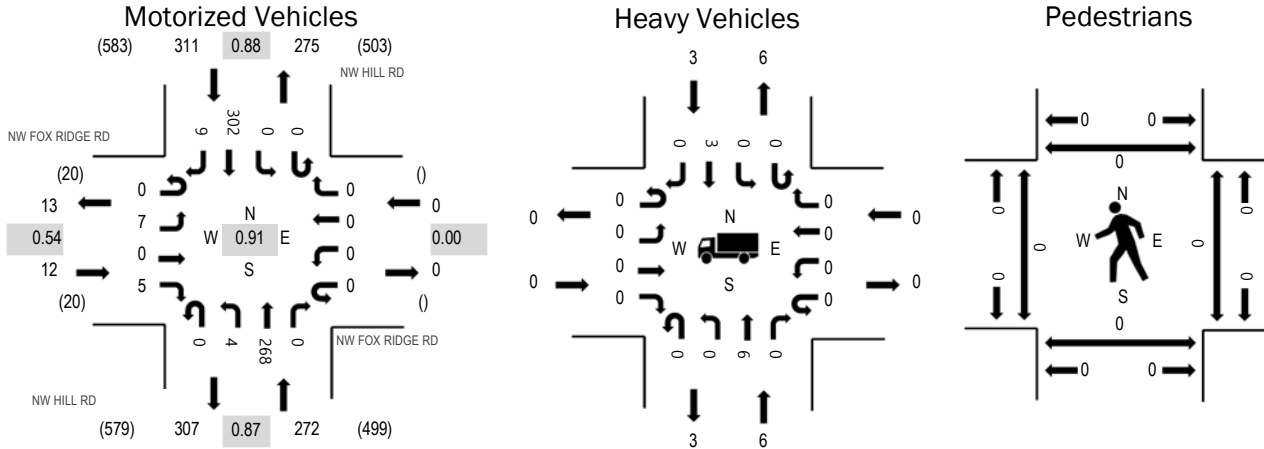

Note: Total study counts contained in parentheses.

	HV%	PHF
EB	0.0%	0.54
WB	0.0%	0.00
NB	2.2%	0.87
SB	1.0%	0.88
All	1.5%	0.91

Traffic Counts - Motorized Vehicles

Interval Start Time	NW FOX RIDGE RD Eastbound				NW FOX RIDGE RD Westbound				NW HILL RD Northbound				NW HILL RD Southbound				Total	Rolling Hour
	U-Turn	Left	Thru	Right	U-Turn	Left	Thru	Right	U-Turn	Left	Thru	Right	U-Turn	Left	Thru	Right		
4:00 PM	0	0	0	0	0	0	0	0	0	0	23	0	0	0	14	0	37	552
4:05 PM	0	0	0	0	0	0	0	0	0	0	23	0	0	0	21	0	44	566
4:10 PM	0	0	0	0	0	0	0	0	0	0	18	0	0	0	30	0	48	572
4:15 PM	0	0	0	0	0	0	0	0	0	0	21	0	0	0	23	1	45	569
4:20 PM	0	0	0	0	0	0	0	0	0	0	20	0	0	0	31	0	51	570
4:25 PM	0	1	0	0	0	0	0	0	0	0	20	0	0	0	16	1	38	576
4:30 PM	0	0	0	2	0	0	0	0	0	0	18	0	0	0	28	1	49	593
4:35 PM	0	0	0	1	0	0	0	0	0	0	22	0	0	0	26	0	49	595
4:40 PM	0	1	0	0	0	0	0	0	0	0	21	0	0	0	27	1	50	588
4:45 PM	0	1	0	0	0	0	0	0	0	0	19	0	0	0	22	1	43	578
4:50 PM	0	0	0	0	0	0	0	0	0	0	31	0	0	0	14	1	46	573
4:55 PM	0	1	0	0	0	0	0	0	0	2	20	0	0	0	29	0	52	567
5:00 PM	0	1	0	1	0	0	0	0	0	0	25	0	0	0	23	1	51	550
5:05 PM	0	0	0	0	0	0	0	0	0	1	17	0	0	0	31	1	50	
5:10 PM	0	0	0	0	0	0	0	0	0	1	20	0	0	0	23	1	45	
5:15 PM	0	0	0	0	0	0	0	0	0	0	24	0	0	0	21	1	46	
5:20 PM	0	2	0	1	0	0	0	0	0	0	23	0	0	0	30	1	57	
5:25 PM	0	1	0	1	0	0	0	0	0	0	25	0	0	0	27	1	55	
5:30 PM	0	0	0	1	0	0	0	0	0	0	21	0	0	0	29	0	51	
5:35 PM	0	1	0	0	0	0	0	0	0	1	21	0	0	0	19	0	42	
5:40 PM	0	0	0	0	0	0	0	0	0	1	20	0	0	0	19	0	40	
5:45 PM	0	0	0	2	0	0	0	0	0	0	15	0	0	0	21	0	38	
5:50 PM	0	0	0	0	0	0	0	0	0	0	13	0	0	0	25	2	40	
5:55 PM	0	1	0	1	0	0	0	0	0	0	13	0	0	0	20	0	35	
Count Total	0	10	0	10	0	0	0	0	0	6	493	0	0	0	569	14	1,102	
Peak Hour	0	7	0	5	0	0	0	0	0	4	268	0	0	0	302	9	595	

Traffic Counts - Heavy Vehicles, Bicycles on Road, and Pedestrians/Bicycles on Crosswalk

Interval Start Time	Heavy Vehicles					Interval Start Time	Bicycles on Roadway					Interval Start Time	Pedestrians/Bicycles on Crosswalk				
	EB	NB	WB	SB	Total		EB	NB	WB	SB	Total		EB	NB	WB	SB	Total
4:00 PM	0	1	0	1	2	4:00 PM	0	0	0	0	0	4:00 PM	0	0	0	0	0
4:05 PM	0	0	0	0	0	4:05 PM	0	0	0	0	0	4:05 PM	0	0	0	0	0
4:10 PM	0	0	0	0	0	4:10 PM	0	0	0	0	0	4:10 PM	0	0	0	0	0
4:15 PM	0	0	0	2	2	4:15 PM	0	0	0	0	0	4:15 PM	0	0	0	0	0
4:20 PM	0	0	0	0	0	4:20 PM	0	0	0	0	0	4:20 PM	0	0	0	0	0
4:25 PM	0	0	0	1	1	4:25 PM	0	0	0	0	0	4:25 PM	0	0	0	0	0
4:30 PM	1	1	0	1	3	4:30 PM	0	0	0	0	0	4:30 PM	0	0	0	2	2
4:35 PM	0	2	0	0	2	4:35 PM	0	0	0	0	0	4:35 PM	0	0	0	0	0
4:40 PM	0	0	0	0	0	4:40 PM	0	0	0	0	0	4:40 PM	0	0	0	0	0
4:45 PM	0	0	0	1	1	4:45 PM	0	0	0	0	0	4:45 PM	0	0	0	0	0
4:50 PM	0	0	0	0	0	4:50 PM	0	0	0	0	0	4:50 PM	0	0	0	0	0
4:55 PM	0	0	0	1	1	4:55 PM	0	0	0	0	0	4:55 PM	0	0	0	2	2
5:00 PM	0	0	0	1	1	5:00 PM	0	0	0	0	0	5:00 PM	0	0	0	0	0
5:05 PM	0	1	0	0	1	5:05 PM	0	0	0	0	0	5:05 PM	0	0	0	0	0
5:10 PM	0	1	0	0	1	5:10 PM	0	0	0	0	0	5:10 PM	0	0	0	0	0
5:15 PM	0	0	0	0	0	5:15 PM	0	0	0	0	0	5:15 PM	0	0	0	0	0
5:20 PM	0	2	0	0	2	5:20 PM	0	0	0	0	0	5:20 PM	0	0	0	0	0
5:25 PM	0	0	0	0	0	5:25 PM	0	0	0	0	0	5:25 PM	0	0	0	0	0
5:30 PM	0	0	0	0	0	5:30 PM	0	1	0	0	1	5:30 PM	0	0	0	0	0
5:35 PM	0	0	0	1	1	5:35 PM	0	0	0	0	0	5:35 PM	0	0	0	0	0
5:40 PM	0	0	0	0	0	5:40 PM	0	0	0	0	0	5:40 PM	0	0	0	0	0
5:45 PM	0	0	0	1	1	5:45 PM	0	0	0	0	0	5:45 PM	0	0	0	0	0
5:50 PM	0	0	0	1	1	5:50 PM	0	0	0	0	0	5:50 PM	0	0	0	0	0
5:55 PM	0	0	0	0	0	5:55 PM	0	0	0	0	0	5:55 PM	0	0	0	0	0
Count Total	1	8	0	11	20	Count Total	0	1	0	0	1	Count Total	0	0	0	4	4
Peak Hour	0	6	0	3	9	Peak Hour	0	1	0	0	1	Peak Hour	0	0	0	2	2

LOS DESCRIPTION

TRAFFIC LEVELS OF SERVICE

Analysis of traffic volumes is useful in understanding the general nature of traffic in an area, but by itself indicates neither the ability of the street network to carry additional traffic nor the quality of service afforded by the street facilities. For this, the concept of level of service has been developed to subjectively describe traffic performance. Level of service can be measured at intersections and along key roadway segments.

Levels of service categories are similar to report card ratings for traffic performance. Intersections are typically the controlling bottlenecks of traffic flow and the ability of a roadway system to carry traffic efficiently is generally diminished in their vicinities. Levels of Service A, B and C indicate conditions where traffic moves without significant delays over periods of peak travel demand. Level of service D and E are progressively worse peak hour operating conditions and F conditions represent where demand exceeds the capacity of an intersection. Most urban communities set level of service D as the minimum acceptable level of service for peak hour operation and plan for level of service C or better for all other times of the day. The Highway Capacity Manual provides level of service calculation methodology for both intersections and arterials¹. The following two sections provide interpretations of the analysis approaches.

¹ *2000 Highway Capacity Manual*, Transportation Research Board, Washington D.C., 2000, Chapter 16 and 17.

UNSIGNALIZED INTERSECTIONS (Two-Way Stop Controlled)

Unsignalized intersection level of service is reported for the major street and minor street (generally, left turn movements). The method assesses available and critical gaps in the traffic stream which make it possible for side street traffic to enter the main street flow. The 2010 Highway Capacity Manual describes the detailed methodology. It is not unusual for an intersection to experience level of service E or F conditions for the minor street left turn movement. It should be understood that, often, a poor level of service is experienced by only a few vehicles and the intersection as a whole operates acceptably.

Unsignalized intersection levels of service are described in the following table.

Level-of-Service Criteria: Automobile Mode

Control Delay (s/vehicle)	LOS by Volume-to-Capacity Ratio	
	$v/c \leq 1.0$	$v/c > 1.0$
0-10	A	F
>10-15	B	F
>15-25	C	F
>25-35	D	F
>35-50	E	F
>50	F	F

Note: The LOS criteria apply to each lane on a given approach and to each approach on the minor street.
LOS is not calculated for major-street approaches or for the intersection as a whole

SIGNALIZED INTERSECTIONS

For signalized intersections, level of service is evaluated based upon average vehicle delay experienced by vehicles entering an intersection. Control delay (or signal delay) includes initial deceleration delay, queue move-up time, stopped delay, and final acceleration delay. In previous versions of this chapter of the HCM (1994 and earlier), delay included only stopped delay. As delay increases, the level of service decreases. Calculations for signalized and unsignalized intersections are different due to the variation in traffic control. The 2000 Highway Capacity Manual provides the basis for these calculations.

Level of Service	Delay (secs.)	Description
A	<10.00	Free Flow/Insignificant Delays: No approach phase is fully utilized by traffic and no vehicle waits longer than one red indication. Most vehicles do not stop at all. Progression is extremely favorable and most vehicles arrive during the green phase.
B	10.1-20.0	Stable Operation/Minimal Delays: An occasional approach phase is fully utilized. Many drivers begin to feel somewhat restricted within platoons of vehicles. This level generally occurs with good progression, short cycle lengths, or both.
C	20.1-35.0	Stable Operation/Acceptable Delays: Major approach phases fully utilized. Most drivers feel somewhat restricted. Higher delays may result from fair progression, longer cycle lengths, or both. Individual cycle failures may begin to appear at this level, and the number of vehicles stopping is significant.
D	35.1-55.0	Approaching Unstable/Tolerable Delays: The influence of congestion becomes more noticeable. Drivers may have to wait through more than one red signal indication. Longer delays may result from some combination of unfavorable progression, long cycle lengths, or high v/c ratios. The proportion of vehicles not stopping declines, and individual cycle failures are noticeable.
E	55.1-80.0	Unstable Operation/Significant Delays: Volumes at or near capacity. Vehicles may wait through several signal cycles. Long queues form upstream from intersection. These high delay values generally indicate poor progression, long cycle lengths, and high v/c ratios. Individual cycle failures are a frequent occurrence.
F	>80.0	Forced Flow/Excessive Delays: Represents jammed conditions. Queues may block upstream intersections. This level occurs when arrival flow rates exceed intersection capacity, and is considered to be unacceptable to most drivers. Poor progression, long cycle lengths, and v/c ratios approaching 1.0 may contribute to these high delay levels.

Source: 2000 Highway Capacity Manual, Transportation Research Board, Washington D.C.

EXISTING 2023 HCM REPORTS

MOVEMENT SUMMARY

Site: 1 [Hill Rd at Baker Creek Rd - AM (Site Folder: General)]

Output produced by SIDRA INTERSECTION Version: 9.1.2.202

Existing Year 2023 Scenario AM Peak Hour

Site Category: Existing Design

Roundabout

Vehicle Movement Performance															
Mov ID	Turn	Mov Class	Demand Flows		Arrival Flows		Deg. Satn	Aver. Delay	Level of Service	95% Back Of Queue		Prop. Que	Eff. Stop Rate	Aver. No. of Cycles	Aver. Speed
			[Total HV] veh/h	%	[Total HV] veh/h	%				[Veh.] veh	[Dist] ft				
South: Hill Rd															
3	L2	All MCs	53	4.0	53	4.0	0.251	5.6	LOS A	1.3	32.3	0.37	0.20	0.37	34.5
8	T1	All MCs	5	0.0	5	0.0	0.251	5.3	LOS A	1.3	32.3	0.37	0.20	0.37	36.0
18	R2	All MCs	226	2.0	226	2.0	0.251	5.4	LOS A	1.3	32.3	0.37	0.20	0.37	35.3
Approach			284	2.3	284	2.3	0.251	5.4	LOS A	1.3	32.3	0.37	0.20	0.37	35.2
East: Baker Creek Rd															
1	L2	All MCs	111	2.0	111	2.0	0.151	3.7	LOS A	0.7	18.0	0.19	0.07	0.19	33.9
6	T1	All MCs	59	28.0	59	28.0	0.151	5.4	LOS A	0.7	18.0	0.19	0.07	0.19	31.8
16	R2	All MCs	6	40.0	6	40.0	0.151	6.2	LOS A	0.7	18.0	0.19	0.07	0.19	30.1
Approach			175	12.0	175	12.0	0.151	4.3	LOS A	0.7	18.0	0.19	0.07	0.19	33.1
North: Hill Rd															
7	L2	All MCs	1	0.0	1	0.0	0.007	3.4	LOS A	0.0	0.7	0.36	0.18	0.36	36.4
4	T1	All MCs	5	0.0	5	0.0	0.007	3.4	LOS A	0.0	0.7	0.36	0.18	0.36	37.3
14	R2	All MCs	1	0.0	1	0.0	0.007	3.4	LOS A	0.0	0.7	0.36	0.18	0.36	36.9
Approach			7	0.0	7	0.0	0.007	3.4	LOS A	0.0	0.7	0.36	0.18	0.36	37.1
West: Baker Creek Rd															
5	L2	All MCs	1	0.0	1	0.0	0.202	4.5	LOS A	1.0	25.2	0.29	0.14	0.29	36.2
2	T1	All MCs	161	4.0	161	4.0	0.202	4.8	LOS A	1.0	25.2	0.29	0.14	0.29	36.5
12	R2	All MCs	76	2.0	76	2.0	0.202	4.7	LOS A	1.0	25.2	0.29	0.14	0.29	36.4
Approach			239	3.3	239	3.3	0.202	4.8	LOS A	1.0	25.2	0.29	0.14	0.29	36.4
All Vehicles			705	5.1	705	5.1	0.251	4.9	LOS A	1.3	32.3	0.30	0.15	0.30	35.0

Site Level of Service (LOS) Method: Delay & v/c (HCM 6). Site LOS Method is specified in the Parameter Settings dialog (Options tab).

Roundabout LOS Method: Same as Sign Control.

Vehicle movement LOS values are based on average delay and v/c ratio (degree of saturation) per movement.

LOS F will result if v/c > 1 irrespective of movement delay value (does not apply for approaches and intersection).

Intersection and Approach LOS values are based on average delay for all movements (v/c not used as specified in HCM 6).

Roundabout Capacity Model: US HCM 6.

Delay Model: HCM Delay Formula (Stopline Delay: Geometric Delay is not included).

Queue Model: SIDRA queue estimation methods are used for Back of Queue and Queue at Start of Gap.

Gap-Acceptance Capacity Formula: Siegloch M1 implied by US HCM 6 Roundabout Capacity Model.

HV (%) values are calculated for All Movement Classes of All Heavy Vehicle Model Designation.

Arrival Flows used in performance calculations are adjusted to include any Initial Queued Demand and Upstream Capacity Constraint effects.

SIDRA INTERSECTION 9.1 | Copyright © 2000-2022 Akcelik and Associates Pty Ltd | sidrasolutions.com

Organisation: DKS ASSOCIATES | Licence: PLUS / FLOATING | Processed: Wednesday, August 9, 2023 12:54:10 PM

Project: S:\Projects\2023\23041-000 (McMinnville Fox Ridge Area Plan TPR)\Analysis\SIDRA\Fox Ridge Road_Roundabout Analysis.sip9

MOVEMENT SUMMARY

Site: 2 [Hill Rd at Wallace Rd - AM (Site Folder: General)]

Output produced by SIDRA INTERSECTION Version: 9.1.2.202

Existing Year 2023 Scenario AM Peak Hour

Site Category: Existing Design

Roundabout

Vehicle Movement Performance															
Mov ID	Turn	Mov Class	Demand Flows		Arrival Flows		Deg. Satn	Aver. Delay	Level of Service	95% Back Of Queue		Prop. Que	Eff. Stop Rate	Aver. No. of Cycles	Aver. Speed
			[Total HV] veh/h	%	[Total HV] veh/h	%				[Veh.] veh	[Dist] ft				
South: Hill Rd															
8	T1	All MCs	259	2.0	259	2.0	0.294	6.2	LOS A	1.5	38.5	0.45	0.27	0.45	32.7
18	R2	All MCs	55	2.0	55	2.0	0.294	6.2	LOS A	1.5	38.5	0.45	0.27	0.45	26.1
Approach			314	2.0	314	2.0	0.294	6.2	LOS A	1.5	38.5	0.45	0.27	0.45	31.4
East: Wallace Rd															
1	L2	All MCs	38	3.0	38	3.0	0.063	4.0	LOS A	0.3	6.6	0.39	0.25	0.39	25.7
16	R2	All MCs	25	10.0	25	10.0	0.063	4.6	LOS A	0.3	6.6	0.39	0.25	0.39	26.9
Approach			63	5.8	63	5.8	0.063	4.2	LOS A	0.3	6.6	0.39	0.25	0.39	26.2
North: Hill Rd															
7	L2	All MCs	219	4.0	219	4.0	0.198	4.4	LOS A	1.0	25.4	0.16	0.05	0.16	27.0
4	T1	All MCs	35	3.0	35	3.0	0.198	4.3	LOS A	1.0	25.4	0.16	0.05	0.16	31.6
Approach			254	3.9	254	3.9	0.198	4.3	LOS A	1.0	25.4	0.16	0.05	0.16	27.6
All Vehicles			630	3.1	630	3.1	0.294	5.2	LOS A	1.5	38.5	0.32	0.18	0.32	29.1

Site Level of Service (LOS) Method: Delay & v/c (HCM 6). Site LOS Method is specified in the Parameter Settings dialog (Options tab).

Roundabout LOS Method: Same as Sign Control.

Vehicle movement LOS values are based on average delay and v/c ratio (degree of saturation) per movement.

LOS F will result if v/c > 1 irrespective of movement delay value (does not apply for approaches and intersection).

Intersection and Approach LOS values are based on average delay for all movements (v/c not used as specified in HCM 6).

Roundabout Capacity Model: US HCM 6.

Delay Model: HCM Delay Formula (Stoptime Delay: Geometric Delay is not included).

Queue Model: SIDRA queue estimation methods are used for Back of Queue and Queue at Start of Gap.

Gap-Acceptance Capacity Formula: Siegloch M1 implied by US HCM 6 Roundabout Capacity Model.

HV (%) values are calculated for All Movement Classes of All Heavy Vehicle Model Designation.

Arrival Flows used in performance calculations are adjusted to include any Initial Queued Demand and Upstream Capacity Constraint effects.

SIDRA INTERSECTION 9.1 | Copyright © 2000-2022 Akcelik and Associates Pty Ltd | sidrasolutions.com

Organisation: DKS ASSOCIATES | Licence: PLUS / FLOATING | Processed: Wednesday, August 9, 2023 12:54:11 PM

Project: S:\Projects\2023\23041-000 (McMinnville Fox Ridge Area Plan TPR)\Analysis\SIDRA\Fox Ridge Road_Roundabout Analysis.sip9

HCM 6th TWSC
3: Fox Ridge Rd & Hill Rd

Intersection

Int Delay, s/veh 0.4

Movement	EBL	EBR	NBL	NBT	SBT	SBR
Lane Configurations	↙↘		↙	↑	↑↘	
Traffic Vol, veh/h	10	3	3	239	195	3
Future Vol, veh/h	10	3	3	239	195	3
Conflicting Peds, #/hr	5	0	3	0	0	3
Sign Control	Stop	Stop	Free	Free	Free	Free
RT Channelized	-	None	-	None	-	None
Storage Length	0	-	200	-	-	-
Veh in Median Storage, #	0	-	-	0	0	-
Grade, %	0	-	-	0	0	-
Peak Hour Factor	86	86	86	86	86	86
Heavy Vehicles, %	0	0	0	2	4	0
Mvmt Flow	12	3	3	278	227	3

Major/Minor	Minor2	Major1	Major2			
Conflicting Flow All	521	232	233	0	-	0
Stage 1	232	-	-	-	-	-
Stage 2	289	-	-	-	-	-
Critical Hdwy	6.4	6.2	4.1	-	-	-
Critical Hdwy Stg 1	5.4	-	-	-	-	-
Critical Hdwy Stg 2	5.4	-	-	-	-	-
Follow-up Hdwy	3.5	3.3	2.2	-	-	-
Pot Cap-1 Maneuver	519	812	1346	-	-	-
Stage 1	811	-	-	-	-	-
Stage 2	765	-	-	-	-	-
Platoon blocked, %				-	-	-
Mov Cap-1 Maneuver	515	810	1342	-	-	-
Mov Cap-2 Maneuver	515	-	-	-	-	-
Stage 1	807	-	-	-	-	-
Stage 2	763	-	-	-	-	-

Approach	EB	NB	SB
HCM Control Delay, s	11.6	0.1	0
HCM LOS	B		

Minor Lane/Major Mvmt	NBL	NBT	EBLn1	SBT	SBR
Capacity (veh/h)	1342	-	562	-	-
HCM Lane V/C Ratio	0.003	-	0.027	-	-
HCM Control Delay (s)	7.7	-	11.6	-	-
HCM Lane LOS	A	-	B	-	-
HCM 95th %tile Q(veh)	0	-	0.1	-	-

Intersection	
Intersection Delay, s/veh	13.4
Intersection LOS	B

Movement	EBL	EBT	EBR	WBL	WBT	WBR	NBL	NBT	NBR	SBL	SBT	SBR
Lane Configurations		↖	↗		↔			↔		↖	↗	
Traffic Vol, veh/h	52	131	21	37	61	58	21	115	85	83	97	29
Future Vol, veh/h	52	131	21	37	61	58	21	115	85	83	97	29
Peak Hour Factor	0.82	0.82	0.82	0.82	0.82	0.82	0.82	0.82	0.82	0.82	0.82	0.82
Heavy Vehicles, %	2	5	10	8	3	2	10	2	5	0	5	3
Mvmt Flow	63	160	26	45	74	71	26	140	104	101	118	35
Number of Lanes	0	1	1	0	1	0	0	1	0	1	1	0

Approach	EB	WB	NB	SB
Opposing Approach	WB	EB	SB	NB
Opposing Lanes	1	2	2	1
Conflicting Approach Left	SB	NB	EB	WB
Conflicting Lanes Left	2	1	2	1
Conflicting Approach Right	NB	SB	WB	EB
Conflicting Lanes Right	1	2	1	2
HCM Control Delay	13.6	13.2	15.2	11.5
HCM LOS	B	B	C	B

Lane	NBLn1	EBLn1	EBLn2	WBLn1	SBLn1	SBLn2
Vol Left, %	10%	28%	0%	24%	100%	0%
Vol Thru, %	52%	72%	0%	39%	0%	77%
Vol Right, %	38%	0%	100%	37%	0%	23%
Sign Control	Stop	Stop	Stop	Stop	Stop	Stop
Traffic Vol by Lane	221	183	21	156	83	126
LT Vol	21	52	0	37	83	0
Through Vol	115	131	0	61	0	97
RT Vol	85	0	21	58	0	29
Lane Flow Rate	270	223	26	190	101	154
Geometry Grp	6	7	7	6	7	7
Degree of Util (X)	0.477	0.413	0.042	0.349	0.195	0.27
Departure Headway (Hd)	6.372	6.656	5.851	6.609	6.918	6.331
Convergence, Y/N	Yes	Yes	Yes	Yes	Yes	Yes
Cap	563	538	608	540	516	564
Service Time	4.448	4.434	3.628	4.695	4.698	4.112
HCM Lane V/C Ratio	0.48	0.414	0.043	0.352	0.196	0.273
HCM Control Delay	15.2	14.1	8.9	13.2	11.4	11.5
HCM Lane LOS	C	B	A	B	B	B
HCM 95th-tile Q	2.6	2	0.1	1.6	0.7	1.1

Intersection						
Int Delay, s/veh	3.5					
Movement	WBL	WBR	NBT	NBR	SBL	SBT
Lane Configurations						
Traffic Vol, veh/h	4	72	108	3	83	123
Future Vol, veh/h	4	72	108	3	83	123
Conflicting Peds, #/hr	0	0	0	1	1	0
Sign Control	Stop	Stop	Free	Free	Free	Free
RT Channelized	-	None	-	None	-	None
Storage Length	0	-	-	-	-	-
Veh in Median Storage, #	0	-	0	-	-	0
Grade, %	0	-	0	-	-	0
Peak Hour Factor	80	80	80	80	80	80
Heavy Vehicles, %	0	8	2	33	6	1
Mvmt Flow	5	90	135	4	104	154

Major/Minor	Minor1	Major1	Major2		
Conflicting Flow All	500	138	0	0	140
Stage 1	138	-	-	-	-
Stage 2	362	-	-	-	-
Critical Hdwy	6.4	6.28	-	-	4.16
Critical Hdwy Stg 1	5.4	-	-	-	-
Critical Hdwy Stg 2	5.4	-	-	-	-
Follow-up Hdwy	3.5	3.372	-	-	2.254
Pot Cap-1 Maneuver	534	895	-	-	1419
Stage 1	894	-	-	-	-
Stage 2	709	-	-	-	-
Platoon blocked, %					
Mov Cap-1 Maneuver	491	894	-	-	1418
Mov Cap-2 Maneuver	491	-	-	-	-
Stage 1	893	-	-	-	-
Stage 2	652	-	-	-	-

Approach	WB	NB	SB
HCM Control Delay, s	9.7	0	3.1
HCM LOS	A		

Minor Lane/Major Mvmt	NBT	NBRWBLn1	SBL	SBT
Capacity (veh/h)	-	-	857	1418
HCM Lane V/C Ratio	-	-	0.111	0.073
HCM Control Delay (s)	-	-	9.7	7.7
HCM Lane LOS	-	-	A	A
HCM 95th %tile Q(veh)	-	-	0.4	0.2

MOVEMENT SUMMARY

Site: 1 [Hill Rd at Baker Creek Rd - PM (Site Folder: General)]

Output produced by SIDRA INTERSECTION Version: 9.1.2.202

Existing Year 2023 Scenario PM Peak Hour

Site Category: Existing Design

Roundabout

Vehicle Movement Performance															
Mov ID	Turn	Mov Class	Demand Flows		Arrival Flows		Deg. Satn	Aver. Delay	Level of Service	95% Back Of Queue		Prop. Que	Eff. Stop Rate	Aver. No. of Cycles	Aver. Speed
			[Total HV] veh/h	%	[Total HV] veh/h	%				[Veh.] veh	[Dist] ft				
South: Hill Rd															
3	L2	All MCs	87	4.0	87	4.0	0.210	4.8	LOS A	1.0	26.7	0.26	0.11	0.26	34.5
8	T1	All MCs	1	0.0	1	0.0	0.210	4.5	LOS A	1.0	26.7	0.26	0.11	0.26	35.9
18	R2	All MCs	169	2.0	169	2.0	0.210	4.7	LOS A	1.0	26.7	0.26	0.11	0.26	35.3
Approach			257	2.7	257	2.7	0.210	4.7	LOS A	1.0	26.7	0.26	0.11	0.26	35.0
East: Baker Creek Rd															
1	L2	All MCs	212	2.0	212	2.0	0.287	5.4	LOS A	1.6	40.0	0.28	0.12	0.28	33.7
6	T1	All MCs	140	2.0	140	2.0	0.287	5.4	LOS A	1.6	40.0	0.28	0.12	0.28	34.5
16	R2	All MCs	1	0.0	1	0.0	0.287	5.3	LOS A	1.6	40.0	0.28	0.12	0.28	34.4
Approach			353	2.0	353	2.0	0.287	5.4	LOS A	1.6	40.0	0.28	0.12	0.28	34.0
North: Hill Rd															
7	L2	All MCs	6	0.0	6	0.0	0.012	4.2	LOS A	0.0	1.2	0.48	0.32	0.48	34.6
4	T1	All MCs	3	0.0	3	0.0	0.012	4.2	LOS A	0.0	1.2	0.48	0.32	0.48	35.4
14	R2	All MCs	1	0.0	1	0.0	0.012	4.2	LOS A	0.0	1.2	0.48	0.32	0.48	35.0
Approach			10	0.0	10	0.0	0.012	4.2	LOS A	0.0	1.2	0.48	0.32	0.48	34.8
West: Baker Creek Rd															
5	L2	All MCs	1	0.0	1	0.0	0.166	4.6	LOS A	0.8	19.2	0.39	0.24	0.39	36.1
2	T1	All MCs	82	3.0	82	3.0	0.166	4.9	LOS A	0.8	19.2	0.39	0.24	0.39	36.5
12	R2	All MCs	94	2.0	94	2.0	0.166	4.8	LOS A	0.8	19.2	0.39	0.24	0.39	36.3
Approach			177	2.5	177	2.5	0.166	4.8	LOS A	0.8	19.2	0.39	0.24	0.39	36.4
All Vehicles			797	2.3	797	2.3	0.287	5.0	LOS A	1.6	40.0	0.30	0.15	0.30	34.8

Site Level of Service (LOS) Method: Delay & v/c (HCM 6). Site LOS Method is specified in the Parameter Settings dialog (Options tab).

Roundabout LOS Method: Same as Sign Control.

Vehicle movement LOS values are based on average delay and v/c ratio (degree of saturation) per movement.

LOS F will result if v/c > 1 irrespective of movement delay value (does not apply for approaches and intersection).

Intersection and Approach LOS values are based on average delay for all movements (v/c not used as specified in HCM 6).

Roundabout Capacity Model: US HCM 6.

Delay Model: HCM Delay Formula (Stopline Delay: Geometric Delay is not included).

Queue Model: SIDRA queue estimation methods are used for Back of Queue and Queue at Start of Gap.

Gap-Acceptance Capacity Formula: Siegloch M1 implied by US HCM 6 Roundabout Capacity Model.

HV (%) values are calculated for All Movement Classes of All Heavy Vehicle Model Designation.

Arrival Flows used in performance calculations are adjusted to include any Initial Queued Demand and Upstream Capacity Constraint effects.

SIDRA INTERSECTION 9.1 | Copyright © 2000-2022 Akcelik and Associates Pty Ltd | sidrasolutions.com

Organisation: DKS ASSOCIATES | Licence: PLUS / FLOATING | Processed: Wednesday, August 9, 2023 12:54:11 PM

Project: S:\Projects\2023\23041-000 (McMinnville Fox Ridge Area Plan TPR)\Analysis\SIDRA\Fox Ridge Road_Roundabout Analysis.sip9

MOVEMENT SUMMARY

Site: 2 [Hill Rd at Wallace Rd - PM (Site Folder: General)]

Output produced by SIDRA INTERSECTION Version: 9.1.2.202

Existing Year 2023 Scenario PM Peak Hour

Site Category: Existing Design

Roundabout

Vehicle Movement Performance															
Mov ID	Turn	Mov Class	Demand Flows		Arrival Flows		Deg. Satn	Aver. Delay	Level of Service	95% Back Of Queue		Prop. Que	Eff. Stop Rate	Aver. No. of Cycles	Aver. Speed
			[Total HV]	%	[Total HV]	%	v/c	sec		[Veh.]	[Dist]				mph
			veh/h		veh/h					veh	ft				
South: Hill Rd															
8	T1	All MCs	267	1.0	267	1.0	0.234	4.5	LOS A	1.2	31.4	0.16	0.05	0.16	33.7
18	R2	All MCs	41	0.0	41	0.0	0.234	4.5	LOS A	1.2	31.4	0.16	0.05	0.16	26.7
Approach			308	0.9	308	0.9	0.234	4.5	LOS A	1.2	31.4	0.16	0.05	0.16	32.5
East: Wallace Rd															
1	L2	All MCs	53	0.0	53	0.0	0.080	4.0	LOS A	0.3	8.5	0.40	0.26	0.40	25.6
16	R2	All MCs	29	8.0	29	8.0	0.080	4.7	LOS A	0.3	8.5	0.40	0.26	0.40	27.0
Approach			81	2.8	81	2.8	0.080	4.3	LOS A	0.3	8.5	0.40	0.26	0.40	26.1
North: Hill Rd															
7	L2	All MCs	34	7.0	34	7.0	0.258	5.3	LOS A	1.4	35.4	0.20	0.07	0.20	28.0
4	T1	All MCs	298	1.0	298	1.0	0.258	4.9	LOS A	1.4	35.4	0.20	0.07	0.20	33.2
Approach			332	1.6	332	1.6	0.258	4.9	LOS A	1.4	35.4	0.20	0.07	0.20	32.6
All Vehicles			721	1.4	721	1.4	0.258	4.7	LOS A	1.4	35.4	0.20	0.08	0.20	31.7

Site Level of Service (LOS) Method: Delay & v/c (HCM 6). Site LOS Method is specified in the Parameter Settings dialog (Options tab).

Roundabout LOS Method: Same as Sign Control.

Vehicle movement LOS values are based on average delay and v/c ratio (degree of saturation) per movement.

LOS F will result if v/c > 1 irrespective of movement delay value (does not apply for approaches and intersection).

Intersection and Approach LOS values are based on average delay for all movements (v/c not used as specified in HCM 6).

Roundabout Capacity Model: US HCM 6.

Delay Model: HCM Delay Formula (Stoptime Delay: Geometric Delay is not included).

Queue Model: SIDRA queue estimation methods are used for Back of Queue and Queue at Start of Gap.

Gap-Acceptance Capacity Formula: Siegloch M1 implied by US HCM 6 Roundabout Capacity Model.

HV (%) values are calculated for All Movement Classes of All Heavy Vehicle Model Designation.

Arrival Flows used in performance calculations are adjusted to include any Initial Queued Demand and Upstream Capacity Constraint effects.

SIDRA INTERSECTION 9.1 | Copyright © 2000-2022 Akcelik and Associates Pty Ltd | sidrasolutions.com

Organisation: DKS ASSOCIATES | Licence: PLUS / FLOATING | Processed: Wednesday, August 9, 2023 12:54:11 PM

Project: S:\Projects\2023\23041-000 (McMinnville Fox Ridge Area Plan TPR)\Analysis\SIDRA\Fox Ridge Road_Roundabout Analysis.sip9

HCM 6th TWSC
3: Fox Ridge Rd & Hill Rd

Intersection						
Int Delay, s/veh	0.3					
Movement	EBL	EBR	NBL	NBT	SBT	SBR
Lane Configurations	↔		↔	↑	↑	
Traffic Vol, veh/h	7	5	4	268	302	9
Future Vol, veh/h	7	5	4	268	302	9
Conflicting Peds, #/hr	0	0	0	0	0	0
Sign Control	Stop	Stop	Free	Free	Free	Free
RT Channelized	-	None	-	None	-	None
Storage Length	0	-	200	-	-	-
Veh in Median Storage, #	0	-	-	0	0	-
Grade, %	0	-	-	0	0	-
Peak Hour Factor	91	91	91	91	91	91
Heavy Vehicles, %	0	0	0	2	1	0
Mvmt Flow	8	5	4	295	332	10

Major/Minor	Minor2	Major1	Major2			
Conflicting Flow All	640	337	342	0	-	0
Stage 1	337	-	-	-	-	-
Stage 2	303	-	-	-	-	-
Critical Hdwy	6.4	6.2	4.1	-	-	-
Critical Hdwy Stg 1	5.4	-	-	-	-	-
Critical Hdwy Stg 2	5.4	-	-	-	-	-
Follow-up Hdwy	3.5	3.3	2.2	-	-	-
Pot Cap-1 Maneuver	443	710	1228	-	-	-
Stage 1	728	-	-	-	-	-
Stage 2	754	-	-	-	-	-
Platoon blocked, %				-	-	-
Mov Cap-1 Maneuver	442	710	1228	-	-	-
Mov Cap-2 Maneuver	442	-	-	-	-	-
Stage 1	726	-	-	-	-	-
Stage 2	754	-	-	-	-	-

Approach	EB	NB	SB
HCM Control Delay, s	12	0.1	0
HCM LOS	B		

Minor Lane/Major Mvmt	NBL	NBT	EBLn1	SBT	SBR
Capacity (veh/h)	1228	-	524	-	-
HCM Lane V/C Ratio	0.004	-	0.025	-	-
HCM Control Delay (s)	7.9	-	12	-	-
HCM Lane LOS	A	-	B	-	-
HCM 95th %tile Q(veh)	0	-	0.1	-	-

Intersection	
Intersection Delay, s/veh	15
Intersection LOS	B

Movement	EBL	EBT	EBR	WBL	WBT	WBR	NBL	NBT	NBR	SBL	SBT	SBR
Lane Configurations		↔	↔		↔			↔		↔	↔	
Traffic Vol, veh/h	43	81	11	61	116	82	19	150	47	68	160	65
Future Vol, veh/h	43	81	11	61	116	82	19	150	47	68	160	65
Peak Hour Factor	0.87	0.87	0.87	0.87	0.87	0.87	0.87	0.87	0.87	0.87	0.87	0.87
Heavy Vehicles, %	0	1	0	3	1	1	0	3	4	1	2	0
Mvmt Flow	49	93	13	70	133	94	22	172	54	78	184	75
Number of Lanes	0	1	1	0	1	0	0	1	0	1	1	0

Approach	EB	WB	NB	SB
Opposing Approach	WB	EB	SB	NB
Opposing Lanes	1	2	2	1
Conflicting Approach Left	SB	NB	EB	WB
Conflicting Lanes Left	2	1	2	1
Conflicting Approach Right	NB	SB	WB	EB
Conflicting Lanes Right	1	2	1	2
HCM Control Delay	12.5	17.5	15.2	13.7
HCM LOS	B	C	C	B

Lane	NBLn1	EBLn1	EBLn2	WBLn1	SBLn1	SBLn2
Vol Left, %	9%	35%	0%	24%	100%	0%
Vol Thru, %	69%	65%	0%	45%	0%	71%
Vol Right, %	22%	0%	100%	32%	0%	29%
Sign Control	Stop	Stop	Stop	Stop	Stop	Stop
Traffic Vol by Lane	216	124	11	259	68	225
LT Vol	19	43	0	61	68	0
Through Vol	150	81	0	116	0	160
RT Vol	47	0	11	82	0	65
Lane Flow Rate	248	143	13	298	78	259
Geometry Grp	6	7	7	6	7	7
Degree of Util (X)	0.458	0.284	0.022	0.55	0.154	0.46
Departure Headway (Hd)	6.647	7.173	6.297	6.645	7.106	6.407
Convergence, Y/N	Yes	Yes	Yes	Yes	Yes	Yes
Cap	541	500	568	545	506	564
Service Time	4.688	4.918	4.041	4.66	4.827	4.129
HCM Lane V/C Ratio	0.458	0.286	0.023	0.547	0.154	0.459
HCM Control Delay	15.2	12.8	9.2	17.5	11.1	14.5
HCM Lane LOS	C	B	A	C	B	B
HCM 95th-tile Q	2.4	1.2	0.1	3.3	0.5	2.4

Intersection						
Int Delay, s/veh	4.2					
Movement	WBL	WBR	NBT	NBR	SBL	SBT
Lane Configurations	T		T		T	
Traffic Vol, veh/h	6	113	129	3	89	105
Future Vol, veh/h	6	113	129	3	89	105
Conflicting Peds, #/hr	0	0	0	0	0	0
Sign Control	Stop	Stop	Free	Free	Free	Free
RT Channelized	-	None	-	None	-	None
Storage Length	0	-	-	-	-	-
Veh in Median Storage, #	0	-	0	-	-	0
Grade, %	0	-	0	-	-	0
Peak Hour Factor	90	90	90	90	90	90
Heavy Vehicles, %	17	2	2	0	2	1
Mvmt Flow	7	126	143	3	99	117

Major/Minor	Minor1	Major1	Major2		
Conflicting Flow All	460	145	0	0	146
Stage 1	145	-	-	-	-
Stage 2	315	-	-	-	-
Critical Hdwy	6.57	6.22	-	-	4.12
Critical Hdwy Stg 1	5.57	-	-	-	-
Critical Hdwy Stg 2	5.57	-	-	-	-
Follow-up Hdwy	3.653	3.318	-	-	2.218
Pot Cap-1 Maneuver	533	902	-	-	1436
Stage 1	847	-	-	-	-
Stage 2	707	-	-	-	-
Platoon blocked, %					
Mov Cap-1 Maneuver	494	902	-	-	1436
Mov Cap-2 Maneuver	494	-	-	-	-
Stage 1	847	-	-	-	-
Stage 2	655	-	-	-	-

Approach	WB	NB	SB
HCM Control Delay, s	9.9	0	3.5
HCM LOS	A		

Minor Lane/Major Mvmt	NBT	NBRWBLn1	SBL	SBT
Capacity (veh/h)	-	-	866	1436
HCM Lane V/C Ratio	-	-	0.153	0.069
HCM Control Delay (s)	-	-	9.9	7.7
HCM Lane LOS	-	-	A	A
HCM 95th %tile Q(veh)	-	-	0.5	0.2

FUTURE BASELINE 2041 HCM REPORTS

MOVEMENT SUMMARY

Site: 1 [Hill Rd at Baker Creek Rd - AM (Site Folder: Future Baseline 2041)]

Output produced by SIDRA INTERSECTION Version: 9.1.4.221

Future Year 2041 Baseline AM Peak Hour
 Site Category: Existing Design
 Roundabout

Vehicle Movement Performance															
Mov ID	Turn	Mov Class	Demand Flows		Arrival Flows		Deg. Satn	Aver. Delay	Level of Service	95% Back Of Queue		Prop. Que	Eff. Stop Rate	Aver. No. of Cycles	Aver. Speed
			[Total HV]	%	[Total HV]	%	v/c	sec		[Veh. veh	Dist]				mph
South: Hill Rd															
3	L2	All MCs	83	4.0	83	4.0	0.331	7.3	LOS A	1.7	43.1	0.53	0.36	0.53	33.5
8	T1	All MCs	11	0.0	11	0.0	0.331	6.8	LOS A	1.7	43.1	0.53	0.36	0.53	34.8
18	R2	All MCs	228	2.0	228	2.0	0.331	7.1	LOS A	1.7	43.1	0.53	0.36	0.53	34.2
Approach			322	2.4	322	2.4	0.331	7.1	LOS A	1.7	43.1	0.53	0.36	0.53	34.0
East: Baker Creek Rd															
1	L2	All MCs	178	2.0	178	2.0	0.257	4.9	LOS A	1.2	33.6	0.29	0.13	0.29	33.3
6	T1	All MCs	94	28.0	94	28.0	0.257	6.8	LOS A	1.2	33.6	0.29	0.13	0.29	31.3
16	R2	All MCs	11	40.0	11	40.0	0.257	7.8	LOS A	1.2	33.6	0.29	0.13	0.29	29.6
Approach			283	12.2	283	12.2	0.257	5.6	LOS A	1.2	33.6	0.29	0.13	0.29	32.5
North: Hill Rd															
7	L2	All MCs	33	0.0	33	0.0	0.054	4.4	LOS A	0.2	5.5	0.46	0.34	0.46	34.3
4	T1	All MCs	11	0.0	11	0.0	0.054	4.4	LOS A	0.2	5.5	0.46	0.34	0.46	35.1
14	R2	All MCs	6	0.0	6	0.0	0.054	4.4	LOS A	0.2	5.5	0.46	0.34	0.46	34.7
Approach			50	0.0	50	0.0	0.054	4.4	LOS A	0.2	5.5	0.46	0.34	0.46	34.5
West: Baker Creek Rd															
5	L2	All MCs	6	0.0	6	0.0	0.369	6.8	LOS A	2.0	52.2	0.48	0.29	0.48	34.8
2	T1	All MCs	261	4.0	261	4.0	0.369	7.2	LOS A	2.0	52.2	0.48	0.29	0.48	35.1
12	R2	All MCs	122	2.0	122	2.0	0.369	7.0	LOS A	2.0	52.2	0.48	0.29	0.48	35.0
Approach			389	3.3	389	3.3	0.369	7.2	LOS A	2.0	52.2	0.48	0.29	0.48	35.1
All Vehicles			1044	5.3	1044	5.3	0.369	6.6	LOS A	2.0	52.2	0.44	0.27	0.44	34.0

Site Level of Service (LOS) Method: Delay & v/c (HCM 6). Site LOS Method is specified in the Parameter Settings dialog (Options tab).

Roundabout LOS Method: Same as Sign Control.

Vehicle movement LOS values are based on average delay and v/c ratio (degree of saturation) per movement.

LOS F will result if v/c > 1 irrespective of movement delay value (does not apply for approaches and intersection).

Intersection and Approach LOS values are based on average delay for all movements (v/c not used as specified in HCM 6).

Roundabout Capacity Model: US HCM 6.

Delay Model: HCM Delay Formula (Stopline Delay: Geometric Delay is not included).

Queue Model: SIDRA queue estimation methods are used for Back of Queue and Queue at Start of Gap.

Gap-Acceptance Capacity Formula: Siegloch M1 implied by US HCM 6 Roundabout Capacity Model.

HV (%) values are calculated for All Movement Classes of All Heavy Vehicle Model Designation.

Arrival Flows used in performance calculations are adjusted to include any Initial Queued Demand and Upstream Capacity Constraint effects.

MOVEMENT SUMMARY

Site: 2 [Hill Rd at Wallace Rd - AM (Site Folder: Future Baseline 2041)]

Output produced by SIDRA INTERSECTION Version: 9.1.4.221

Future Year 2041 Baseline AM Peak Hour
 Site Category: Existing Design
 Roundabout

Vehicle Movement Performance															
Mov ID	Turn	Mov Class	Demand Flows		Arrival Flows		Deg. Satn	Aver. Delay	Level of Service	95% Back Of Queue	Prop. Que	Eff. Stop Rate	Aver. No. of Cycles	Aver. Speed	
			[Total HV]	%	[Total HV]	%	v/c	sec		[Veh. veh	Dist]			mph	
South: Hill Rd															
3	L2	All MCs	167	1.0	167	1.0	0.439	7.5	LOS A	2.8	71.4	0.45	0.24	0.45	30.3
8	T1	All MCs	256	2.0	256	2.0	0.439	7.6	LOS A	2.8	71.4	0.45	0.24	0.45	31.8
18	R2	All MCs	83	2.0	83	2.0	0.439	7.6	LOS A	2.8	71.4	0.45	0.24	0.45	25.6
Approach			506	1.7	506	1.7	0.439	7.6	LOS A	2.8	71.4	0.45	0.24	0.45	30.1
East: Wallace Rd															
1	L2	All MCs	56	3.0	56	3.0	0.200	6.6	LOS A	0.8	21.5	0.57	0.46	0.57	27.1
6	T1	All MCs	61	1.0	61	1.0	0.200	6.4	LOS A	0.8	21.5	0.57	0.46	0.57	28.7
16	R2	All MCs	39	10.0	39	10.0	0.200	7.7	LOS A	0.8	21.5	0.57	0.46	0.57	28.5
Approach			156	4.0	156	4.0	0.200	6.8	LOS A	0.8	21.5	0.57	0.46	0.57	28.1
North: Hill Rd															
7	L2	All MCs	56	4.0	56	4.0	0.406	8.2	LOS A	2.3	57.8	0.55	0.36	0.55	26.6
4	T1	All MCs	200	3.0	200	3.0	0.406	8.1	LOS A	2.3	57.8	0.55	0.36	0.55	31.2
14	R2	All MCs	150	1.0	150	1.0	0.406	7.8	LOS A	2.3	57.8	0.55	0.36	0.55	32.5
Approach			406	2.4	406	2.4	0.406	8.0	LOS A	2.3	57.8	0.55	0.36	0.55	30.9
West: Wallace Road															
5	L2	All MCs	78	1.0	78	1.0	0.181	5.4	LOS A	0.8	20.7	0.47	0.32	0.47	31.9
2	T1	All MCs	22	1.0	22	1.0	0.181	5.4	LOS A	0.8	20.7	0.47	0.32	0.47	32.5
12	R2	All MCs	78	1.0	78	1.0	0.181	5.4	LOS A	0.8	20.7	0.47	0.32	0.47	32.3
Approach			178	1.0	178	1.0	0.181	5.4	LOS A	0.8	20.7	0.47	0.32	0.47	32.1
All Vehicles			1244	2.1	1244	2.1	0.439	7.3	LOS A	2.8	71.4	0.50	0.32	0.50	30.4

Site Level of Service (LOS) Method: Delay & v/c (HCM 6). Site LOS Method is specified in the Parameter Settings dialog (Options tab).

Roundabout LOS Method: Same as Sign Control.

Vehicle movement LOS values are based on average delay and v/c ratio (degree of saturation) per movement.

LOS F will result if v/c > 1 irrespective of movement delay value (does not apply for approaches and intersection).

Intersection and Approach LOS values are based on average delay for all movements (v/c not used as specified in HCM 6).

Roundabout Capacity Model: US HCM 6.

Delay Model: HCM Delay Formula (Stopline Delay: Geometric Delay is not included).

Queue Model: SIDRA queue estimation methods are used for Back of Queue and Queue at Start of Gap.

Gap-Acceptance Capacity Formula: Siegloch M1 implied by US HCM 6 Roundabout Capacity Model.

HV (%) values are calculated for All Movement Classes of All Heavy Vehicle Model Designation.

Arrival Flows used in performance calculations are adjusted to include any Initial Queued Demand and Upstream Capacity Constraint effects.

Intersection						
Int Delay, s/veh	0.4					
Movement	EBL	EBR	NBL	NBT	SBT	SBR
Lane Configurations	Y		Y	↑	↑	
Traffic Vol, veh/h	15	5	5	410	315	5
Future Vol, veh/h	15	5	5	410	315	5
Conflicting Peds, #/hr	5	0	3	0	0	3
Sign Control	Stop	Stop	Free	Free	Free	Free
RT Channelized	-	None	-	None	-	None
Storage Length	0	-	200	-	-	-
Veh in Median Storage, #	0	-	-	0	0	-
Grade, %	0	-	-	0	0	-
Peak Hour Factor	90	90	90	90	90	90
Heavy Vehicles, %	0	0	0	2	4	0
Mvmt Flow	17	6	6	456	350	6

Major/Minor	Minor2	Major1		Major2	
Conflicting Flow All	829	356	359	0	0
Stage 1	356	-	-	-	-
Stage 2	473	-	-	-	-
Critical Hdwy	6.4	6.2	4.1	-	-
Critical Hdwy Stg 1	5.4	-	-	-	-
Critical Hdwy Stg 2	5.4	-	-	-	-
Follow-up Hdwy	3.5	3.3	2.2	-	-
Pot Cap-1 Maneuver	343	693	1211	-	-
Stage 1	713	-	-	-	-
Stage 2	631	-	-	-	-
Platoon blocked, %				-	-
Mov Cap-1 Maneuver	339	691	1208	-	-
Mov Cap-2 Maneuver	339	-	-	-	-
Stage 1	707	-	-	-	-
Stage 2	629	-	-	-	-

Approach	EB	NB	SB
HCM Control Delay, s	14.8	0.1	0
HCM LOS	B		

Minor Lane/Major Mvmt	NBL	NBT	EBLn1	SBT	SBR
Capacity (veh/h)	1208	-	388	-	-
HCM Lane V/C Ratio	0.005	-	0.057	-	-
HCM Control Delay (s)	8	-	14.8	-	-
HCM Lane LOS	A	-	B	-	-
HCM 95th %tile Q(veh)	0	-	0.2	-	-

Intersection	
Intersection Delay, s/veh	48
Intersection LOS	E

Movement	EBL	EBT	EBR	WBL	WBT	WBR	NBL	NBT	NBR	SBL	SBT	SBR
Lane Configurations		↖	↗		↔			↔		↖	↗	
Traffic Vol, veh/h	90	225	35	65	105	100	35	200	145	145	145	50
Future Vol, veh/h	90	225	35	65	105	100	35	200	145	145	145	50
Peak Hour Factor	0.90	0.90	0.90	0.90	0.90	0.90	0.90	0.90	0.90	0.90	0.90	0.90
Heavy Vehicles, %	2	5	10	8	3	2	10	2	5	0	5	3
Mvmt Flow	100	250	39	72	117	111	39	222	161	161	161	56
Number of Lanes	0	1	1	0	1	0	0	1	0	1	1	0

Approach	EB	WB	NB	SB
Opposing Approach	WB	EB	SB	NB
Opposing Lanes	1	2	2	1
Conflicting Approach Left	SB	NB	EB	WB
Conflicting Lanes Left	2	1	2	1
Conflicting Approach Right	NB	SB	WB	EB
Conflicting Lanes Right	1	2	1	2
HCM Control Delay	43.9	36.9	84.3	20.5
HCM LOS	E	E	F	C

Lane	NBLn1	EBLn1	EBLn2	WBLn1	SBLn1	SBLn2
Vol Left, %	9%	29%	0%	24%	100%	0%
Vol Thru, %	53%	71%	0%	39%	0%	74%
Vol Right, %	38%	0%	100%	37%	0%	26%
Sign Control	Stop	Stop	Stop	Stop	Stop	Stop
Traffic Vol by Lane	380	315	35	270	145	195
LT Vol	35	90	0	65	145	0
Through Vol	200	225	0	105	0	145
RT Vol	145	0	35	100	0	50
Lane Flow Rate	422	350	39	300	161	217
Geometry Grp	4b	5	5	4b	5	5
Degree of Util (X)	1.035	0.859	0.087	0.76	0.42	0.527
Departure Headway (Hd)	8.823	9.134	8.309	9.469	9.701	9.081
Convergence, Y/N	Yes	Yes	Yes	Yes	Yes	Yes
Cap	414	399	434	384	374	399
Service Time	6.823	6.834	6.009	7.469	7.401	6.781
HCM Lane V/C Ratio	1.019	0.877	0.09	0.781	0.43	0.544
HCM Control Delay	84.3	47.5	11.8	36.9	19.2	21.5
HCM Lane LOS	F	E	B	E	C	C
HCM 95th-tile Q	13.5	8.3	0.3	6.2	2	3

Intersection												
Int Delay, s/veh	6.9											
Movement	EBL	EBT	EBR	WBL	WBT	WBR	NBL	NBT	NBR	SBL	SBT	SBR
Lane Configurations		↕			↕			↕			↕	
Traffic Vol, veh/h	25	55	10	5	25	125	10	185	5	130	190	15
Future Vol, veh/h	25	55	10	5	25	125	10	185	5	130	190	15
Conflicting Peds, #/hr	0	0	0	0	0	0	0	0	1	1	0	0
Sign Control	Stop	Stop	Stop	Stop	Stop	Stop	Free	Free	Free	Free	Free	Free
RT Channelized	-	-	None	-	-	None	-	-	None	-	-	None
Storage Length	-	-	-	-	-	-	-	-	-	-	-	-
Veh in Median Storage, #	-	0	-	-	0	-	-	0	-	-	0	-
Grade, %	-	0	-	-	0	-	-	0	-	-	0	-
Peak Hour Factor	90	90	90	90	90	90	90	90	90	90	90	90
Heavy Vehicles, %	0	0	0	0	0	8	0	2	33	6	1	0
Mvmt Flow	28	61	11	6	28	139	11	206	6	144	211	17

Major/Minor	Minor2		Minor1		Major1		Major2					
Conflicting Flow All	823	743	220	776	748	210	228	0	0	213	0	0
Stage 1	508	508	-	232	232	-	-	-	-	-	-	-
Stage 2	315	235	-	544	516	-	-	-	-	-	-	-
Critical Hdwy	7.1	6.5	6.2	7.1	6.5	6.28	4.1	-	-	4.16	-	-
Critical Hdwy Stg 1	6.1	5.5	-	6.1	5.5	-	-	-	-	-	-	-
Critical Hdwy Stg 2	6.1	5.5	-	6.1	5.5	-	-	-	-	-	-	-
Follow-up Hdwy	3.5	4	3.3	3.5	4	3.372	2.2	-	-	2.254	-	-
Pot Cap-1 Maneuver	295	346	825	317	343	815	1352	-	-	1334	-	-
Stage 1	551	542	-	775	716	-	-	-	-	-	-	-
Stage 2	700	714	-	527	538	-	-	-	-	-	-	-
Platoon blocked, %								-	-	-	-	-
Mov Cap-1 Maneuver	204	300	825	238	297	814	1352	-	-	1333	-	-
Mov Cap-2 Maneuver	204	300	-	238	297	-	-	-	-	-	-	-
Stage 1	546	475	-	767	709	-	-	-	-	-	-	-
Stage 2	553	707	-	397	471	-	-	-	-	-	-	-

Approach	EB		WB		NB		SB			
HCM Control Delay, s	24.5		13.4		0.4		3.1			
HCM LOS	C		B							

Minor Lane/Major Mvmt	NBL	NBT	NBR	EBLn1WBLn1	SBL	SBT	SBR
Capacity (veh/h)	1352	-	-	283	599	1333	-
HCM Lane V/C Ratio	0.008	-	-	0.353	0.288	0.108	-
HCM Control Delay (s)	7.7	0	-	24.5	13.4	8	0
HCM Lane LOS	A	A	-	C	B	A	A
HCM 95th %tile Q(veh)	0	-	-	1.5	1.2	0.4	-

MOVEMENT SUMMARY

Site: 1 [Hill Rd at Baker Creek Rd - PM (Site Folder: Future Baseline 2041)]

Output produced by SIDRA INTERSECTION Version: 9.1.4.221

Future Year 2041 Baseline PM Peak Hour

Site Category: NA

Roundabout

Vehicle Movement Performance															
Mov ID	Turn	Mov Class	Demand Flows		Arrival Flows		Deg. Satn	Aver. Delay	Level of Service	95% Back Of Queue	Prop. Que	Eff. Stop Rate	Aver. No. of Cycles	Aver. Speed	
			[Total HV]	%	[Total HV]	%	v/c	sec		[Veh. veh	Dist]			mph	
South: Hill Rd															
3	L2	All MCs	148	4.0	148	4.0	0.402	7.4	LOS A	2.4	61.2	0.45	0.25	0.45	33.2
8	T1	All MCs	10	0.0	10	0.0	0.402	7.0	LOS A	2.4	61.2	0.45	0.25	0.45	34.5
18	R2	All MCs	291	2.0	291	2.0	0.402	7.2	LOS A	2.4	61.2	0.45	0.25	0.45	33.9
Approach			449	2.6	449	2.6	0.402	7.3	LOS A	2.4	61.2	0.45	0.25	0.45	33.7
East: Baker Creek Rd															
1	L2	All MCs	367	2.0	367	2.0	0.561	9.7	LOS A	4.3	108.1	0.56	0.30	0.56	31.8
6	T1	All MCs	240	2.0	240	2.0	0.561	9.7	LOS A	4.3	108.1	0.56	0.30	0.56	32.5
16	R2	All MCs	31	0.0	31	0.0	0.561	9.5	LOS A	4.3	108.1	0.56	0.30	0.56	32.4
Approach			638	1.9	638	1.9	0.561	9.7	LOS A	4.3	108.1	0.56	0.30	0.56	32.1
North: Hill Rd															
7	L2	All MCs	26	0.0	26	0.0	0.073	6.6	LOS A	0.3	7.0	0.61	0.56	0.61	33.5
4	T1	All MCs	15	0.0	15	0.0	0.073	6.6	LOS A	0.3	7.0	0.61	0.56	0.61	34.3
14	R2	All MCs	5	0.0	5	0.0	0.073	6.6	LOS A	0.3	7.0	0.61	0.56	0.61	34.0
Approach			46	0.0	46	0.0	0.073	6.6	LOS A	0.3	7.0	0.61	0.56	0.61	33.8
West: Baker Creek Rd															
5	L2	All MCs	5	0.0	5	0.0	0.356	7.8	LOS A	1.8	45.1	0.60	0.45	0.60	34.3
2	T1	All MCs	143	3.0	143	3.0	0.356	8.2	LOS A	1.8	45.1	0.60	0.45	0.60	34.7
12	R2	All MCs	163	2.0	163	2.0	0.356	8.1	LOS A	1.8	45.1	0.60	0.45	0.60	34.5
Approach			311	2.4	311	2.4	0.356	8.1	LOS A	1.8	45.1	0.60	0.45	0.60	34.6
All Vehicles			1444	2.2	1444	2.2	0.561	8.5	LOS A	4.3	108.1	0.54	0.33	0.54	33.1

Site Level of Service (LOS) Method: Delay & v/c (HCM 6). Site LOS Method is specified in the Parameter Settings dialog (Options tab).

Roundabout LOS Method: Same as Sign Control.

Vehicle movement LOS values are based on average delay and v/c ratio (degree of saturation) per movement.

LOS F will result if v/c > 1 irrespective of movement delay value (does not apply for approaches and intersection).

Intersection and Approach LOS values are based on average delay for all movements (v/c not used as specified in HCM 6).

Roundabout Capacity Model: US HCM 6.

Delay Model: HCM Delay Formula (Stopline Delay: Geometric Delay is not included).

Queue Model: SIDRA queue estimation methods are used for Back of Queue and Queue at Start of Gap.

Gap-Acceptance Capacity Formula: Siegloch M1 implied by US HCM 6 Roundabout Capacity Model.

HV (%) values are calculated for All Movement Classes of All Heavy Vehicle Model Designation.

Arrival Flows used in performance calculations are adjusted to include any Initial Queued Demand and Upstream Capacity Constraint effects.

SIDRA INTERSECTION 9.1 | Copyright © 2000-2023 Akcelik and Associates Pty Ltd | sidrasolutions.com

Organisation: DKS ASSOCIATES | Licence: PLUS / FLOATING | Processed: Monday, November 20, 2023 9:51:36 AM

Project: S:\Projects\2023\23041-000 (McMinnville Fox Ridge Area Plan TPR)\5_Analysis\SIDRA\Fox Ridge Road_Roundabout Analysis.sip9

MOVEMENT SUMMARY

Site: 2 [Hill Rd at Wallace Rd - PM (Site Folder: Future Baseline 2041)]

Output produced by SIDRA INTERSECTION Version: 9.1.4.221

Future Year 2041 Baseline PM Peak Hour
 Site Category: NA
 Roundabout

Vehicle Movement Performance															
Mov ID	Turn	Mov Class	Demand Flows		Arrival Flows		Deg. Satn	Aver. Delay	Level of Service	95% Back Of Queue	Prop. Que	Eff. Stop Rate	Aver. No. of Cycles	Aver. Speed	
			[Total HV]	%	[Total HV]	%	v/c	sec		[Veh. Dist]				mph	
			veh/h		veh/h					veh	ft				
South: Hill Rd															
3	L2	All MCs	33	0.0	33	0.0	0.417	6.9	LOSA	2.7	68.6	0.37	0.17	0.37	30.9
8	T1	All MCs	407	1.0	407	1.0	0.417	7.0	LOSA	2.7	68.6	0.37	0.17	0.37	32.5
18	R2	All MCs	71	0.0	71	0.0	0.417	6.9	LOSA	2.7	68.6	0.37	0.17	0.37	25.9
Approach			511	0.8	511	0.8	0.417	6.9	LOSA	2.7	68.6	0.37	0.17	0.37	31.3
East: Wallace Rd															
1	L2	All MCs	82	0.0	82	0.0	0.175	5.8	LOSA	0.7	18.8	0.55	0.43	0.55	25.5
6	T1	All MCs	11	0.0	11	0.0	0.175	5.8	LOSA	0.7	18.8	0.55	0.43	0.55	26.9
16	R2	All MCs	49	8.0	49	8.0	0.175	6.9	LOSA	0.7	18.8	0.55	0.43	0.55	26.9
Approach			143	2.8	143	2.8	0.175	6.2	LOSA	0.7	18.8	0.55	0.43	0.55	26.1
North: Hill Rd															
7	L2	All MCs	60	6.0	60	6.0	0.483	8.4	LOSA	3.4	86.1	0.43	0.21	0.43	26.9
4	T1	All MCs	478	1.0	478	1.0	0.483	8.0	LOSA	3.4	86.1	0.43	0.21	0.43	31.6
14	R2	All MCs	38	0.0	38	0.0	0.483	7.9	LOSA	3.4	86.1	0.43	0.21	0.43	32.9
Approach			577	1.5	577	1.5	0.483	8.0	LOSA	3.4	86.1	0.43	0.21	0.43	31.1
West: Wallace Road															
5	L2	All MCs	33	0.0	33	0.0	0.121	6.2	LOSA	0.5	12.3	0.59	0.51	0.59	31.7
2	T1	All MCs	11	0.0	11	0.0	0.121	6.2	LOSA	0.5	12.3	0.59	0.51	0.59	32.3
12	R2	All MCs	44	0.0	44	0.0	0.121	6.2	LOSA	0.5	12.3	0.59	0.51	0.59	32.0
Approach			88	0.0	88	0.0	0.121	6.2	LOSA	0.5	12.3	0.59	0.51	0.59	31.9
All Vehicles			1319	1.2	1319	1.2	0.483	7.3	LOSA	3.4	86.1	0.43	0.24	0.43	30.6

Site Level of Service (LOS) Method: Delay & v/c (HCM 6). Site LOS Method is specified in the Parameter Settings dialog (Options tab).

Roundabout LOS Method: Same as Sign Control.

Vehicle movement LOS values are based on average delay and v/c ratio (degree of saturation) per movement.

LOS F will result if v/c > 1 irrespective of movement delay value (does not apply for approaches and intersection).

Intersection and Approach LOS values are based on average delay for all movements (v/c not used as specified in HCM 6).

Roundabout Capacity Model: US HCM 6.

Delay Model: HCM Delay Formula (Stopline Delay: Geometric Delay is not included).

Queue Model: SIDRA queue estimation methods are used for Back of Queue and Queue at Start of Gap.

Gap-Acceptance Capacity Formula: Siegloch M1 implied by US HCM 6 Roundabout Capacity Model.

HV (%) values are calculated for All Movement Classes of All Heavy Vehicle Model Designation.

Arrival Flows used in performance calculations are adjusted to include any Initial Queued Demand and Upstream Capacity Constraint effects.

Intersection						
Int Delay, s/veh	0.4					
Movement	EBL	EBR	NBL	NBT	SBT	SBR
Lane Configurations						
Traffic Vol, veh/h	10	10	5	460	520	15
Future Vol, veh/h	10	10	5	460	520	15
Conflicting Peds, #/hr	0	0	0	0	0	0
Sign Control	Stop	Stop	Free	Free	Free	Free
RT Channelized	-	None	-	None	-	None
Storage Length	0	-	200	-	-	-
Veh in Median Storage, #	0	-	-	0	0	-
Grade, %	0	-	-	0	0	-
Peak Hour Factor	91	91	91	91	91	91
Heavy Vehicles, %	0	0	0	2	1	0
Mvmt Flow	11	11	5	505	571	16

Major/Minor	Minor2	Major1	Major2			
Conflicting Flow All	1094	579	587	0	-	0
Stage 1	579	-	-	-	-	-
Stage 2	515	-	-	-	-	-
Critical Hdwy	6.4	6.2	4.1	-	-	-
Critical Hdwy Stg 1	5.4	-	-	-	-	-
Critical Hdwy Stg 2	5.4	-	-	-	-	-
Follow-up Hdwy	3.5	3.3	2.2	-	-	-
Pot Cap-1 Maneuver	239	519	998	-	-	-
Stage 1	564	-	-	-	-	-
Stage 2	604	-	-	-	-	-
Platoon blocked, %				-	-	-
Mov Cap-1 Maneuver	238	519	998	-	-	-
Mov Cap-2 Maneuver	238	-	-	-	-	-
Stage 1	561	-	-	-	-	-
Stage 2	604	-	-	-	-	-

Approach	EB	NB	SB
HCM Control Delay, s	16.8	0.1	0
HCM LOS	C		

Minor Lane/Major Mvmt	NBL	NBT	EBLn1	SBT	SBR
Capacity (veh/h)	998	-	326	-	-
HCM Lane V/C Ratio	0.006	-	0.067	-	-
HCM Control Delay (s)	8.6	-	16.8	-	-
HCM Lane LOS	A	-	C	-	-
HCM 95th %tile Q(veh)	0	-	0.2	-	-

Intersection	
Intersection Delay, s/veh	100.6
Intersection LOS	F

Movement	EBL	EBT	EBR	WBL	WBT	WBR	NBL	NBT	NBR	SBL	SBT	SBR
Lane Configurations		↖	↗		↔			↔		↖	↗	
Traffic Vol, veh/h	75	140	20	105	200	140	35	260	80	115	275	110
Future Vol, veh/h	75	140	20	105	200	140	35	260	80	115	275	110
Peak Hour Factor	0.90	0.90	0.90	0.90	0.90	0.90	0.90	0.90	0.90	0.90	0.90	0.90
Heavy Vehicles, %	0	1	0	3	1	1	0	3	4	1	2	0
Mvmt Flow	83	156	22	117	222	156	39	289	89	128	306	122
Number of Lanes	0	1	1	0	1	0	0	1	0	1	1	0

Approach	EB	WB	NB	SB
Opposing Approach	WB	EB	SB	NB
Opposing Lanes	1	2	2	1
Conflicting Approach Left	SB	NB	EB	WB
Conflicting Lanes Left	2	1	2	1
Conflicting Approach Right	NB	SB	WB	EB
Conflicting Lanes Right	1	2	1	2
HCM Control Delay	30.5	167.6	99.1	75
HCM LOS	D	F	F	F

Lane	NBLn1	EBLn1	EBLn2	WBLn1	SBLn1	SBLn2
Vol Left, %	9%	35%	0%	24%	100%	0%
Vol Thru, %	69%	65%	0%	45%	0%	71%
Vol Right, %	21%	0%	100%	31%	0%	29%
Sign Control	Stop	Stop	Stop	Stop	Stop	Stop
Traffic Vol by Lane	375	215	20	445	115	385
LT Vol	35	75	0	105	115	0
Through Vol	260	140	0	200	0	275
RT Vol	80	0	20	140	0	110
Lane Flow Rate	417	239	22	494	128	428
Geometry Grp	4b	5	5	4b	5	5
Degree of Util (X)	1.064	0.655	0.056	1.265	0.337	1.047
Departure Headway (Hd)	10.24	10.907	10.002	9.701	10.523	9.806
Convergence, Y/N	Yes	Yes	Yes	Yes	Yes	Yes
Cap	358	334	360	381	344	372
Service Time	8.24	8.607	7.702	7.701	8.223	7.506
HCM Lane V/C Ratio	1.165	0.716	0.061	1.297	0.372	1.151
HCM Control Delay	99.1	32.1	13.3	167.6	18.5	91.9
HCM Lane LOS	F	D	B	F	C	F
HCM 95th-tile Q	13.3	4.4	0.2	20.8	1.5	13.1

Intersection												
Int Delay, s/veh	7.9											
Movement	EBL	EBT	EBR	WBL	WBT	WBR	NBL	NBT	NBR	SBL	SBT	SBR
Lane Configurations		↕			↕			↕			↕	
Traffic Vol, veh/h	20	35	5	10	50	145	10	170	5	155	180	30
Future Vol, veh/h	20	35	5	10	50	145	10	170	5	155	180	30
Conflicting Peds, #/hr	0	0	0	0	0	0	0	0	0	0	0	0
Sign Control	Stop	Stop	Stop	Stop	Stop	Stop	Free	Free	Free	Free	Free	Free
RT Channelized	-	-	None	-	-	None	-	-	None	-	-	None
Storage Length	-	-	-	-	-	-	-	-	-	-	-	-
Veh in Median Storage, #	-	0	-	-	0	-	-	0	-	-	0	-
Grade, %	-	0	-	-	0	-	-	0	-	-	0	-
Peak Hour Factor	90	90	90	90	90	90	90	90	90	90	90	90
Heavy Vehicles, %	0	0	0	17	0	2	0	2	0	2	1	0
Mvmt Flow	22	39	6	11	56	161	11	189	6	172	200	33

Major/Minor	Minor2		Minor1		Major1			Major2				
Conflicting Flow All	884	778	217	797	791	192	233	0	0	195	0	0
Stage 1	561	561	-	214	214	-	-	-	-	-	-	-
Stage 2	323	217	-	583	577	-	-	-	-	-	-	-
Critical Hdwy	7.1	6.5	6.2	7.27	6.5	6.22	4.1	-	-	4.12	-	-
Critical Hdwy Stg 1	6.1	5.5	-	6.27	5.5	-	-	-	-	-	-	-
Critical Hdwy Stg 2	6.1	5.5	-	6.27	5.5	-	-	-	-	-	-	-
Follow-up Hdwy	3.5	4	3.3	3.653	4	3.318	2.2	-	-	2.218	-	-
Pot Cap-1 Maneuver	268	330	828	287	324	850	1346	-	-	1378	-	-
Stage 1	516	513	-	755	729	-	-	-	-	-	-	-
Stage 2	693	727	-	473	505	-	-	-	-	-	-	-
Platoon blocked, %								-	-	-	-	-
Mov Cap-1 Maneuver	163	280	828	226	275	850	1346	-	-	1378	-	-
Mov Cap-2 Maneuver	163	280	-	226	275	-	-	-	-	-	-	-
Stage 1	511	439	-	748	722	-	-	-	-	-	-	-
Stage 2	514	720	-	367	432	-	-	-	-	-	-	-

Approach	EB		WB		NB		SB	
HCM Control Delay, s	26.2		17.3		0.4		3.4	
HCM LOS	D		C					

Minor Lane/Major Mvmt	NBL	NBT	NBR	EBLn1WBLn1	SBL	SBT	SBR
Capacity (veh/h)	1346	-	-	236	517	1378	-
HCM Lane V/C Ratio	0.008	-	-	0.282	0.441	0.125	-
HCM Control Delay (s)	7.7	0	-	26.2	17.3	8	0
HCM Lane LOS	A	A	-	D	C	A	A
HCM 95th %tile Q(veh)	0	-	-	1.1	2.2	0.4	-

PREFERRED SCENARIO 2041 HCM REPORTS

MOVEMENT SUMMARY

Site: 1 [Hill Rd at Baker Creek Rd - AM (Site Folder: Future Preferred Scenario 2044)]

Output produced by SIDRA INTERSECTION Version: 9.1.4.221

Future Year 2041 Preferred AM Peak Hour
 Site Category: Existing Design
 Roundabout

Vehicle Movement Performance															
Mov ID	Turn	Mov Class	Demand Flows		Arrival Flows		Deg. Satn	Aver. Delay	Level of Service	95% Back Of Queue	Dist	Prop. Que	Eff. Stop Rate	Aver. No. of Cycles	Aver. Speed
			[Total HV]	%	[Total HV]	%	v/c	sec		[Veh. veh	ft				mph
South: Hill Rd															
3	L2	All MCs	96	4.0	96	4.0	0.422	8.6	LOS A	2.4	60.2	0.58	0.39	0.58	32.9
8	T1	All MCs	11	0.0	11	0.0	0.422	8.1	LOS A	2.4	60.2	0.58	0.39	0.58	34.2
18	R2	All MCs	304	2.0	304	2.0	0.422	8.3	LOS A	2.4	60.2	0.58	0.39	0.58	33.6
Approach			411	2.4	411	2.4	0.422	8.4	LOS A	2.4	60.2	0.58	0.39	0.58	33.5
East: Baker Creek Rd															
1	L2	All MCs	212	2.0	212	2.0	0.289	5.3	LOS A	1.4	39.2	0.32	0.15	0.32	33.1
6	T1	All MCs	94	28.0	94	28.0	0.289	7.3	LOS A	1.4	39.2	0.32	0.15	0.32	31.0
16	R2	All MCs	11	40.0	11	40.0	0.289	8.3	LOS A	1.4	39.2	0.32	0.15	0.32	29.4
Approach			318	11.1	318	11.1	0.289	5.9	LOS A	1.4	39.2	0.32	0.15	0.32	32.3
North: Hill Rd															
7	L2	All MCs	33	0.0	33	0.0	0.057	4.6	LOS A	0.2	5.8	0.49	0.37	0.49	34.2
4	T1	All MCs	11	0.0	11	0.0	0.057	4.6	LOS A	0.2	5.8	0.49	0.37	0.49	34.9
14	R2	All MCs	6	0.0	6	0.0	0.057	4.6	LOS A	0.2	5.8	0.49	0.37	0.49	34.6
Approach			50	0.0	50	0.0	0.057	4.6	LOS A	0.2	5.8	0.49	0.37	0.49	34.4
West: Baker Creek Rd															
5	L2	All MCs	6	0.0	6	0.0	0.388	7.3	LOS A	2.1	54.9	0.52	0.33	0.52	34.5
2	T1	All MCs	261	4.0	261	4.0	0.388	7.7	LOS A	2.1	54.9	0.52	0.33	0.52	34.8
12	R2	All MCs	128	2.0	128	2.0	0.388	7.5	LOS A	2.1	54.9	0.52	0.33	0.52	34.8
Approach			394	3.3	394	3.3	0.388	7.6	LOS A	2.1	54.9	0.52	0.33	0.52	34.8
All Vehicles			1173	4.9	1173	4.9	0.422	7.3	LOS A	2.4	60.2	0.49	0.31	0.49	33.6

Site Level of Service (LOS) Method: Delay & v/c (HCM 6). Site LOS Method is specified in the Parameter Settings dialog (Options tab).

Roundabout LOS Method: Same as Sign Control.

Vehicle movement LOS values are based on average delay and v/c ratio (degree of saturation) per movement.

LOS F will result if v/c > 1 irrespective of movement delay value (does not apply for approaches and intersection).

Intersection and Approach LOS values are based on average delay for all movements (v/c not used as specified in HCM 6).

Roundabout Capacity Model: US HCM 6.

Delay Model: HCM Delay Formula (Stopline Delay: Geometric Delay is not included).

Queue Model: SIDRA queue estimation methods are used for Back of Queue and Queue at Start of Gap.

Gap-Acceptance Capacity Formula: Siegloch M1 implied by US HCM 6 Roundabout Capacity Model.

HV (%) values are calculated for All Movement Classes of All Heavy Vehicle Model Designation.

Arrival Flows used in performance calculations are adjusted to include any Initial Queued Demand and Upstream Capacity Constraint effects.

MOVEMENT SUMMARY

Site: 2 [Hill Rd at Wallace Rd - AM (Site Folder: Future Preferred Scenario 2044)]

Output produced by SIDRA INTERSECTION Version: 9.1.4.221

Future Year 2041 Preferred AM Peak Hour
 Site Category: Existing Design
 Roundabout

Vehicle Movement Performance															
Mov ID	Turn	Mov Class	Demand Flows		Arrival Flows		Deg. Satn	Aver. Delay	Level of Service	95% Back Of Queue	Dist	Prop. Que	Eff. Stop Rate	Aver. No. of Cycles	Aver. Speed
			[Total HV]	%	[Total HV]	%	v/c	sec		[Veh. veh	ft				mph
South: Hill Rd															
3	L2	All MCs	187	1.0	187	1.0	0.553	9.7	LOS A	4.0	101.5	0.59	0.34	0.59	29.5
8	T1	All MCs	312	2.0	312	2.0	0.553	9.8	LOS A	4.0	101.5	0.59	0.34	0.59	30.9
18	R2	All MCs	109	2.0	109	2.0	0.553	9.8	LOS A	4.0	101.5	0.59	0.34	0.59	25.0
Approach			608	1.7	608	1.7	0.553	9.8	LOS A	4.0	101.5	0.59	0.34	0.59	29.2
East: Wallace Rd															
1	L2	All MCs	67	3.0	67	3.0	0.249	8.0	LOS A	1.0	26.5	0.63	0.54	0.63	26.6
6	T1	All MCs	67	1.0	67	1.0	0.249	7.6	LOS A	1.0	26.5	0.63	0.54	0.63	28.1
16	R2	All MCs	39	10.0	39	10.0	0.249	9.3	LOS A	1.0	26.5	0.63	0.54	0.63	27.9
Approach			172	3.8	172	3.8	0.249	8.1	LOS A	1.0	26.5	0.63	0.54	0.63	27.5
North: Hill Rd															
7	L2	All MCs	56	4.0	56	4.0	0.463	9.3	LOS A	2.8	71.8	0.61	0.43	0.64	26.3
4	T1	All MCs	226	3.0	226	3.0	0.463	9.2	LOS A	2.8	71.8	0.61	0.43	0.64	30.7
14	R2	All MCs	164	1.0	164	1.0	0.463	9.0	LOS A	2.8	71.8	0.61	0.43	0.64	32.0
Approach			446	2.4	446	2.4	0.463	9.2	LOS A	2.8	71.8	0.61	0.43	0.64	30.5
West: Wallace Road															
5	L2	All MCs	110	1.0	110	1.0	0.281	6.7	LOS A	1.4	34.5	0.53	0.38	0.53	31.4
2	T1	All MCs	34	1.0	34	1.0	0.281	6.7	LOS A	1.4	34.5	0.53	0.38	0.53	32.0
12	R2	All MCs	121	1.0	121	1.0	0.281	6.7	LOS A	1.4	34.5	0.53	0.38	0.53	31.7
Approach			266	1.0	266	1.0	0.281	6.7	LOS A	1.4	34.5	0.53	0.38	0.53	31.6
All Vehicles			1491	2.0	1491	2.0	0.553	8.9	LOS A	4.0	101.5	0.59	0.40	0.60	29.8

Site Level of Service (LOS) Method: Delay & v/c (HCM 6). Site LOS Method is specified in the Parameter Settings dialog (Options tab).

Roundabout LOS Method: Same as Sign Control.

Vehicle movement LOS values are based on average delay and v/c ratio (degree of saturation) per movement.

LOS F will result if v/c > 1 irrespective of movement delay value (does not apply for approaches and intersection).

Intersection and Approach LOS values are based on average delay for all movements (v/c not used as specified in HCM 6).

Roundabout Capacity Model: US HCM 6.

Delay Model: HCM Delay Formula (Stopline Delay: Geometric Delay is not included).

Queue Model: SIDRA queue estimation methods are used for Back of Queue and Queue at Start of Gap.

Gap-Acceptance Capacity Formula: Siegloch M1 implied by US HCM 6 Roundabout Capacity Model.

HV (%) values are calculated for All Movement Classes of All Heavy Vehicle Model Designation.

Arrival Flows used in performance calculations are adjusted to include any Initial Queued Demand and Upstream Capacity Constraint effects.

Intersection						
Int Delay, s/veh	4.3					
Movement	EBL	EBR	NBL	NBT	SBT	SBR
Lane Configurations						
Traffic Vol, veh/h	89	79	37	428	355	37
Future Vol, veh/h	89	79	37	428	355	37
Conflicting Peds, #/hr	5	0	3	0	0	3
Sign Control	Stop	Stop	Free	Free	Free	Free
RT Channelized	-	None	-	None	-	None
Storage Length	0	-	200	-	-	-
Veh in Median Storage, #	0	-	-	0	0	-
Grade, %	0	-	-	0	0	-
Peak Hour Factor	90	90	90	90	90	90
Heavy Vehicles, %	0	0	0	2	4	0
Mvmt Flow	99	88	41	476	394	41

Major/Minor	Minor2	Major1		Major2	
Conflicting Flow All	981	418	438	0	0
Stage 1	418	-	-	-	-
Stage 2	563	-	-	-	-
Critical Hdwy	6.4	6.2	4.1	-	-
Critical Hdwy Stg 1	5.4	-	-	-	-
Critical Hdwy Stg 2	5.4	-	-	-	-
Follow-up Hdwy	3.5	3.3	2.2	-	-
Pot Cap-1 Maneuver	279	639	1133	-	-
Stage 1	669	-	-	-	-
Stage 2	574	-	-	-	-
Platoon blocked, %				-	-
Mov Cap-1 Maneuver	267	637	1130	-	-
Mov Cap-2 Maneuver	267	-	-	-	-
Stage 1	643	-	-	-	-
Stage 2	572	-	-	-	-

Approach	EB	NB	SB
HCM Control Delay, s	24.5	0.7	0
HCM LOS	C		

Minor Lane/Major Mvmt	NBL	NBT	EBLn1	SBT	SBR
Capacity (veh/h)	1130	-	367	-	-
HCM Lane V/C Ratio	0.036	-	0.509	-	-
HCM Control Delay (s)	8.3	-	24.5	-	-
HCM Lane LOS	A	-	C	-	-
HCM 95th %tile Q(veh)	0.1	-	2.8	-	-

Intersection	
Intersection Delay, s/veh	69.3
Intersection LOS	F

Movement	EBL	EBT	EBR	WBL	WBT	WBR	NBL	NBT	NBR	SBL	SBT	SBR
Lane Configurations		↔	↔		↔			↔		↔	↔	
Traffic Vol, veh/h	95	225	35	65	105	130	35	215	145	213	179	62
Future Vol, veh/h	95	225	35	65	105	130	35	215	145	213	179	62
Peak Hour Factor	0.90	0.90	0.90	0.90	0.90	0.90	0.90	0.90	0.90	0.90	0.90	0.90
Heavy Vehicles, %	2	5	10	8	3	2	10	2	5	0	5	3
Mvmt Flow	106	250	39	72	117	144	39	239	161	237	199	69
Number of Lanes	0	1	1	0	1	0	0	1	0	1	1	0

Approach	EB	WB	NB	SB
Opposing Approach	WB	EB	SB	NB
Opposing Lanes	1	2	2	1
Conflicting Approach Left	SB	NB	EB	WB
Conflicting Lanes Left	2	1	2	1
Conflicting Approach Right	NB	SB	WB	EB
Conflicting Lanes Right	1	2	1	2
HCM Control Delay	57.4	56.7	134.3	30.4
HCM LOS	F	F	F	D

Lane	NBLn1	EBLn1	EBLn2	WBLn1	SBLn1	SBLn2
Vol Left, %	9%	30%	0%	22%	100%	0%
Vol Thru, %	54%	70%	0%	35%	0%	74%
Vol Right, %	37%	0%	100%	43%	0%	26%
Sign Control	Stop	Stop	Stop	Stop	Stop	Stop
Traffic Vol by Lane	395	320	35	300	213	241
LT Vol	35	95	0	65	213	0
Through Vol	215	225	0	105	0	179
RT Vol	145	0	35	130	0	62
Lane Flow Rate	439	356	39	333	237	268
Geometry Grp	4b	5	5	4b	5	5
Degree of Util (X)	1.177	0.924	0.092	0.885	0.64	0.68
Departure Headway (Hd)	9.651	10.005	9.169	10.35	10.409	9.785
Convergence, Y/N	Yes	Yes	Yes	Yes	Yes	Yes
Cap	377	366	393	353	350	372
Service Time	7.651	7.705	6.869	8.35	8.109	7.485
HCM Lane V/C Ratio	1.164	0.973	0.099	0.943	0.677	0.72
HCM Control Delay	134.3	62.3	12.8	56.7	29.9	30.9
HCM Lane LOS	F	F	B	F	D	D
HCM 95th-tile Q	17.6	9.6	0.3	8.5	4.2	4.8

Intersection												
Int Delay, s/veh	7.6											
Movement	EBL	EBT	EBR	WBL	WBT	WBR	NBL	NBT	NBR	SBL	SBT	SBR
Lane Configurations		↕			↕			↕			↕	
Traffic Vol, veh/h	25	55	10	5	25	135	10	190	5	153	201	15
Future Vol, veh/h	25	55	10	5	25	135	10	190	5	153	201	15
Conflicting Peds, #/hr	0	0	0	0	0	0	0	0	1	1	0	0
Sign Control	Stop	Stop	Stop	Stop	Stop	Stop	Free	Free	Free	Free	Free	Free
RT Channelized	-	-	None	-	-	None	-	-	None	-	-	None
Storage Length	-	-	-	-	-	-	-	-	-	-	-	-
Veh in Median Storage, #	-	0	-	-	0	-	-	0	-	-	0	-
Grade, %	-	0	-	-	0	-	-	0	-	-	0	-
Peak Hour Factor	90	90	90	90	90	90	90	90	90	90	90	90
Heavy Vehicles, %	0	0	0	0	0	8	0	2	33	6	1	0
Mvmt Flow	28	61	11	6	28	150	11	211	6	170	223	17

Major/Minor	Minor2		Minor1		Major1			Major2				
Conflicting Flow All	897	812	232	845	817	215	240	0	0	218	0	0
Stage 1	572	572	-	237	237	-	-	-	-	-	-	-
Stage 2	325	240	-	608	580	-	-	-	-	-	-	-
Critical Hdwy	7.1	6.5	6.2	7.1	6.5	6.28	4.1	-	-	4.16	-	-
Critical Hdwy Stg 1	6.1	5.5	-	6.1	5.5	-	-	-	-	-	-	-
Critical Hdwy Stg 2	6.1	5.5	-	6.1	5.5	-	-	-	-	-	-	-
Follow-up Hdwy	3.5	4	3.3	3.5	4	3.372	2.2	-	-	2.254	-	-
Pot Cap-1 Maneuver	263	315	812	285	313	810	1339	-	-	1328	-	-
Stage 1	509	508	-	771	713	-	-	-	-	-	-	-
Stage 2	692	711	-	486	503	-	-	-	-	-	-	-
Platoon blocked, %								-	-	-	-	-
Mov Cap-1 Maneuver	174	266	812	205	264	809	1339	-	-	1327	-	-
Mov Cap-2 Maneuver	174	266	-	205	264	-	-	-	-	-	-	-
Stage 1	504	433	-	763	706	-	-	-	-	-	-	-
Stage 2	537	704	-	351	429	-	-	-	-	-	-	-

Approach	EB		WB		NB		SB	
HCM Control Delay, s	29		14.1		0.4		3.4	
HCM LOS	D		B					

Minor Lane/Major Mvmt	NBL	NBT	NBR	EBLn1	WBLn1	SBL	SBT	SBR
Capacity (veh/h)	1339	-	-	248	577	1327	-	-
HCM Lane V/C Ratio	0.008	-	-	0.403	0.318	0.128	-	-
HCM Control Delay (s)	7.7	0	-	29	14.1	8.1	0	-
HCM Lane LOS	A	A	-	D	B	A	A	-
HCM 95th %tile Q(veh)	0	-	-	1.8	1.4	0.4	-	-

MOVEMENT SUMMARY

Site: 1 [Hill Rd at Baker Creek Rd - PM (Site Folder: Future Preferred Scenario 2044)]

Output produced by SIDRA INTERSECTION Version: 9.1.4.221

Future Year 2041 Preferred PM Peak Hour

Site Category: NA

Roundabout

Vehicle Movement Performance															
Mov ID	Turn	Mov Class	Demand Flows		Arrival Flows		Deg. Satn	Aver. Delay	Level of Service	95% Back Of Queue		Prop. Que	Eff. Stop Rate	Aver. No. of Cycles	Aver. Speed
			[Total HV]	%	[Total HV]	%	v/c	sec		[Veh.]	[Dist]				mph
			veh/h		veh/h					veh	ft				
South: Hill Rd															
3	L2	All MCs	159	4.0	159	4.0	0.470	8.4	LOS A	3.1	78.3	0.50	0.27	0.50	32.8
8	T1	All MCs	10	0.0	10	0.0	0.470	8.0	LOS A	3.1	78.3	0.50	0.27	0.50	34.1
18	R2	All MCs	356	2.0	356	2.0	0.470	8.2	LOS A	3.1	78.3	0.50	0.27	0.50	33.5
Approach			526	2.6	526	2.6	0.470	8.2	LOS A	3.1	78.3	0.50	0.27	0.50	33.3
East: Baker Creek Rd															
1	L2	All MCs	462	2.0	462	2.0	0.652	11.9	LOS B	6.7	169.8	0.66	0.40	0.72	30.7
6	T1	All MCs	240	2.0	240	2.0	0.652	11.9	LOS B	6.7	169.8	0.66	0.40	0.72	31.4
16	R2	All MCs	31	0.0	31	0.0	0.652	11.7	LOS B	6.7	169.8	0.66	0.40	0.72	31.3
Approach			733	1.9	733	1.9	0.652	11.9	LOS B	6.7	169.8	0.66	0.40	0.72	31.0
North: Hill Rd															
7	L2	All MCs	26	0.0	26	0.0	0.082	7.4	LOS A	0.3	7.7	0.64	0.61	0.64	33.1
4	T1	All MCs	15	0.0	15	0.0	0.082	7.4	LOS A	0.3	7.7	0.64	0.61	0.64	33.9
14	R2	All MCs	5	0.0	5	0.0	0.082	7.4	LOS A	0.3	7.7	0.64	0.61	0.64	33.6
Approach			46	0.0	46	0.0	0.082	7.4	LOS A	0.3	7.7	0.64	0.61	0.64	33.4
West: Baker Creek Rd															
5	L2	All MCs	5	0.0	5	0.0	0.414	9.4	LOS A	2.3	58.6	0.67	0.57	0.77	33.4
2	T1	All MCs	143	3.0	143	3.0	0.414	9.8	LOS A	2.3	58.6	0.67	0.57	0.77	33.8
12	R2	All MCs	179	2.0	179	2.0	0.414	9.7	LOS A	2.3	58.6	0.67	0.57	0.77	33.6
Approach			327	2.4	327	2.4	0.414	9.7	LOS A	2.3	58.6	0.67	0.57	0.77	33.7
All Vehicles			1631	2.2	1631	2.2	0.652	10.2	LOS B	6.7	169.8	0.61	0.40	0.66	32.3

Site Level of Service (LOS) Method: Delay & v/c (HCM 6). Site LOS Method is specified in the Parameter Settings dialog (Options tab).

Roundabout LOS Method: Same as Sign Control.

Vehicle movement LOS values are based on average delay and v/c ratio (degree of saturation) per movement.

LOS F will result if v/c > 1 irrespective of movement delay value (does not apply for approaches and intersection).

Intersection and Approach LOS values are based on average delay for all movements (v/c not used as specified in HCM 6).

Roundabout Capacity Model: US HCM 6.

Delay Model: HCM Delay Formula (Stopline Delay: Geometric Delay is not included).

Queue Model: SIDRA queue estimation methods are used for Back of Queue and Queue at Start of Gap.

Gap-Acceptance Capacity Formula: Siegloch M1 implied by US HCM 6 Roundabout Capacity Model.

HV (%) values are calculated for All Movement Classes of All Heavy Vehicle Model Designation.

Arrival Flows used in performance calculations are adjusted to include any Initial Queued Demand and Upstream Capacity Constraint effects.

SIDRA INTERSECTION 9.1 | Copyright © 2000-2023 Akcelik and Associates Pty Ltd | sidrasolutions.com

Organisation: DKS ASSOCIATES | Licence: PLUS / FLOATING | Processed: Monday, November 20, 2023 9:51:38 AM

Project: S:\Projects\2023\23041-000 (McMinnville Fox Ridge Area Plan TPR)\5_Analysis\SIDRA\Fox Ridge Road_Roundabout Analysis.sip9

MOVEMENT SUMMARY

Site: 2 [Hill Rd at Wallace Rd - PM (Site Folder: Future Preferred Scenario 2044)]

Output produced by SIDRA INTERSECTION Version: 9.1.4.221

Future Year 2041 Preferred PM Peak Hour

Site Category: NA

Roundabout

Vehicle Movement Performance															
Mov ID	Turn	Mov Class	Demand Flows		Arrival Flows		Deg. Satn	Aver. Delay	Level of Service	95% Back Of Queue	Dist	Prop. Que	Eff. Stop Rate	Aver. No. of Cycles	Aver. Speed
			[Total HV]	%	[Total HV]	%	v/c	sec		[Veh. veh	ft				mph
South: Hill Rd															
3	L2	All MCs	92	0.0	92	0.0	0.550	9.2	LOS A	4.2	106.6	0.52	0.27	0.52	29.9
8	T1	All MCs	460	1.0	460	1.0	0.550	9.3	LOS A	4.2	106.6	0.52	0.27	0.52	31.4
18	R2	All MCs	93	0.0	93	0.0	0.550	9.2	LOS A	4.2	106.6	0.52	0.27	0.52	25.2
Approach			646	0.7	646	0.7	0.550	9.2	LOS A	4.2	106.6	0.52	0.27	0.52	30.1
East: Wallace Rd															
1	L2	All MCs	116	0.0	116	0.0	0.272	7.9	LOS A	1.2	29.8	0.64	0.55	0.64	25.2
6	T1	All MCs	27	0.0	27	0.0	0.272	7.9	LOS A	1.2	29.8	0.64	0.55	0.64	26.5
16	R2	All MCs	49	8.0	49	8.0	0.272	9.4	LOS A	1.2	29.8	0.64	0.55	0.64	26.5
Approach			193	2.0	193	2.0	0.272	8.3	LOS A	1.2	29.8	0.64	0.55	0.64	25.7
North: Hill Rd															
7	L2	All MCs	60	6.0	60	6.0	0.652	12.9	LOS B	8.1	205.2	0.72	0.55	0.95	25.6
4	T1	All MCs	555	1.0	555	1.0	0.652	12.4	LOS B	8.1	205.2	0.72	0.55	0.95	29.8
14	R2	All MCs	80	0.0	80	0.0	0.652	12.2	LOS B	8.1	205.2	0.72	0.55	0.95	30.9
Approach			696	1.3	696	1.3	0.652	12.4	LOS B	8.1	205.2	0.72	0.55	0.95	29.5
West: Wallace Road															
5	L2	All MCs	62	0.0	62	0.0	0.261	8.8	LOS A	1.1	27.8	0.67	0.60	0.67	30.6
2	T1	All MCs	23	0.0	23	0.0	0.261	8.8	LOS A	1.1	27.8	0.67	0.60	0.67	31.2
12	R2	All MCs	85	0.0	85	0.0	0.261	8.8	LOS A	1.1	27.8	0.67	0.60	0.67	30.9
Approach			169	0.0	169	0.0	0.261	8.8	LOS A	1.1	27.8	0.67	0.60	0.67	30.8
All Vehicles			1704	1.0	1704	1.0	0.652	10.4	LOS B	8.1	205.2	0.63	0.45	0.72	29.3

Site Level of Service (LOS) Method: Delay & v/c (HCM 6). Site LOS Method is specified in the Parameter Settings dialog (Options tab).

Roundabout LOS Method: Same as Sign Control.

Vehicle movement LOS values are based on average delay and v/c ratio (degree of saturation) per movement.

LOS F will result if v/c > 1 irrespective of movement delay value (does not apply for approaches and intersection).

Intersection and Approach LOS values are based on average delay for all movements (v/c not used as specified in HCM 6).

Roundabout Capacity Model: US HCM 6.

Delay Model: HCM Delay Formula (Stopline Delay: Geometric Delay is not included).

Queue Model: SIDRA queue estimation methods are used for Back of Queue and Queue at Start of Gap.

Gap-Acceptance Capacity Formula: Siegloch M1 implied by US HCM 6 Roundabout Capacity Model.

HV (%) values are calculated for All Movement Classes of All Heavy Vehicle Model Designation.

Arrival Flows used in performance calculations are adjusted to include any Initial Queued Demand and Upstream Capacity Constraint effects.

SIDRA INTERSECTION 9.1 | Copyright © 2000-2023 Akcelik and Associates Pty Ltd | sidrasolutions.com

Organisation: DKS ASSOCIATES | Licence: PLUS / FLOATING | Processed: Monday, November 20, 2023 9:51:39 AM

Project: S:\Projects\2023\23041-000 (McMinnville Fox Ridge Area Plan TPR)\5_Analysis\SIDRA\Fox Ridge Road_Roundabout Analysis.sip9

Intersection						
Int Delay, s/veh	10.9					
Movement	EBL	EBR	NBL	NBT	SBT	SBR
Lane Configurations						
Traffic Vol, veh/h	80	80	105	514	558	115
Future Vol, veh/h	80	80	105	514	558	115
Conflicting Peds, #/hr	0	0	0	0	0	0
Sign Control	Stop	Stop	Free	Free	Free	Free
RT Channelized	-	None	-	None	-	None
Storage Length	0	-	200	-	-	-
Veh in Median Storage, #	0	-	-	0	0	-
Grade, %	0	-	-	0	0	-
Peak Hour Factor	91	91	91	91	91	91
Heavy Vehicles, %	0	0	0	2	1	0
Mvmt Flow	88	88	115	565	613	126

Major/Minor	Minor2	Major1	Major2			
Conflicting Flow All	1471	676	739	0	-	0
Stage 1	676	-	-	-	-	-
Stage 2	795	-	-	-	-	-
Critical Hdwy	6.4	6.2	4.1	-	-	-
Critical Hdwy Stg 1	5.4	-	-	-	-	-
Critical Hdwy Stg 2	5.4	-	-	-	-	-
Follow-up Hdwy	3.5	3.3	2.2	-	-	-
Pot Cap-1 Maneuver	141	457	876	-	-	-
Stage 1	509	-	-	-	-	-
Stage 2	448	-	-	-	-	-
Platoon blocked, %				-	-	-
Mov Cap-1 Maneuver	123	457	876	-	-	-
Mov Cap-2 Maneuver	123	-	-	-	-	-
Stage 1	442	-	-	-	-	-
Stage 2	448	-	-	-	-	-

Approach	EB	NB	SB
HCM Control Delay, s	92	1.7	0
HCM LOS	F		

Minor Lane/Major Mvmt	NBL	NBT	EBLn1	SBT	SBR
Capacity (veh/h)	876	-	194	-	-
HCM Lane V/C Ratio	0.132	-	0.906	-	-
HCM Control Delay (s)	9.7	-	92	-	-
HCM Lane LOS	A	-	F	-	-
HCM 95th %tile Q(veh)	0.5	-	7.1	-	-

Intersection	
Intersection Delay, s/veh	156.4
Intersection LOS	F

Movement	EBL	EBT	EBR	WBL	WBT	WBR	NBL	NBT	NBR	SBL	SBT	SBR
Lane Configurations		↖	↗		↔			↔		↖	↗	
Traffic Vol, veh/h	91	140	20	105	200	232	35	306	80	179	307	121
Future Vol, veh/h	91	140	20	105	200	232	35	306	80	179	307	121
Peak Hour Factor	0.90	0.90	0.90	0.90	0.90	0.90	0.90	0.90	0.90	0.90	0.90	0.90
Heavy Vehicles, %	0	1	0	3	1	1	0	3	4	1	2	0
Mvmt Flow	101	156	22	117	222	258	39	340	89	199	341	134
Number of Lanes	0	1	1	0	1	0	0	1	0	1	1	0

Approach	EB	WB	NB	SB
Opposing Approach	WB	EB	SB	NB
Opposing Lanes	1	2	2	1
Conflicting Approach Left	SB	NB	EB	WB
Conflicting Lanes Left	2	1	2	1
Conflicting Approach Right	NB	SB	WB	EB
Conflicting Lanes Right	1	2	1	2
HCM Control Delay	36.9	275.6	150.6	104.3
HCM LOS	E	F	F	F

Lane	NBLn1	EBLn1	EBLn2	WBLn1	SBLn1	SBLn2
Vol Left, %	8%	39%	0%	20%	100%	0%
Vol Thru, %	73%	61%	0%	37%	0%	72%
Vol Right, %	19%	0%	100%	43%	0%	28%
Sign Control	Stop	Stop	Stop	Stop	Stop	Stop
Traffic Vol by Lane	421	231	20	537	179	428
LT Vol	35	91	0	105	179	0
Through Vol	306	140	0	200	0	307
RT Vol	80	0	20	232	0	121
Lane Flow Rate	468	257	22	597	199	476
Geometry Grp	4b	5	5	4b	5	5
Degree of Util (X)	1.204	0.705	0.056	1.524	0.527	1.171
Departure Headway (Hd)	11.223	11.974	11.039	10.192	11.578	10.857
Convergence, Y/N	Yes	Yes	Yes	Yes	Yes	Yes
Cap	327	305	326	364	314	338
Service Time	9.223	9.674	8.739	8.192	9.278	8.557
HCM Lane V/C Ratio	1.431	0.843	0.067	1.64	0.634	1.408
HCM Control Delay	150.6	38.9	14.4	275.6	26.5	136.9
HCM Lane LOS	F	E	B	F	D	F
HCM 95th-tile Q	16.8	5	0.2	29.9	2.9	16.1

Intersection												
Int Delay, s/veh	9.1											
Movement	EBL	EBT	EBR	WBL	WBT	WBR	NBL	NBT	NBR	SBL	SBT	SBR
Lane Configurations		↕			↕			↕			↕	
Traffic Vol, veh/h	20	35	5	10	50	176	10	185	5	176	191	30
Future Vol, veh/h	20	35	5	10	50	176	10	185	5	176	191	30
Conflicting Peds, #/hr	0	0	0	0	0	0	0	0	0	0	0	0
Sign Control	Stop	Stop	Stop	Stop	Stop	Stop	Free	Free	Free	Free	Free	Free
RT Channelized	-	-	None	-	-	None	-	-	None	-	-	None
Storage Length	-	-	-	-	-	-	-	-	-	-	-	-
Veh in Median Storage, #	-	0	-	-	0	-	-	0	-	-	0	-
Grade, %	-	0	-	-	0	-	-	0	-	-	0	-
Peak Hour Factor	90	90	90	90	90	90	90	90	90	90	90	90
Heavy Vehicles, %	0	0	0	17	0	2	0	2	0	2	1	0
Mvmt Flow	22	39	6	11	56	196	11	206	6	196	212	33

Major/Minor	Minor2		Minor1		Major1			Major2				
Conflicting Flow All	978	855	229	874	868	209	245	0	0	212	0	0
Stage 1	621	621	-	231	231	-	-	-	-	-	-	-
Stage 2	357	234	-	643	637	-	-	-	-	-	-	-
Critical Hdwy	7.1	6.5	6.2	7.27	6.5	6.22	4.1	-	-	4.12	-	-
Critical Hdwy Stg 1	6.1	5.5	-	6.27	5.5	-	-	-	-	-	-	-
Critical Hdwy Stg 2	6.1	5.5	-	6.27	5.5	-	-	-	-	-	-	-
Follow-up Hdwy	3.5	4	3.3	3.653	4	3.318	2.2	-	-	2.218	-	-
Pot Cap-1 Maneuver	232	298	815	254	293	831	1333	-	-	1358	-	-
Stage 1	478	482	-	739	717	-	-	-	-	-	-	-
Stage 2	665	715	-	438	475	-	-	-	-	-	-	-
Platoon blocked, %								-	-	-	-	-
Mov Cap-1 Maneuver	127	246	815	193	242	831	1333	-	-	1358	-	-
Mov Cap-2 Maneuver	127	246	-	193	242	-	-	-	-	-	-	-
Stage 1	474	401	-	732	711	-	-	-	-	-	-	-
Stage 2	465	709	-	327	395	-	-	-	-	-	-	-

Approach	EB		WB		NB		SB	
HCM Control Delay, s	32.6		19.7		0.4		3.6	
HCM LOS	D		C					

Minor Lane/Major Mvmt	NBL	NBT	NBR	EBLn1WBLn1	SBL	SBT	SBR
Capacity (veh/h)	1333	-	-	196	502	1358	-
HCM Lane V/C Ratio	0.008	-	-	0.34	0.522	0.144	-
HCM Control Delay (s)	7.7	0	-	32.6	19.7	8.1	0
HCM Lane LOS	A	A	-	D	C	A	A
HCM 95th %tile Q(veh)	0	-	-	1.4	3	0.5	-

RECOMMENDED IMPROVEMENTS HCM REPORTS

MOVEMENT SUMMARY

Site: 1 [Hill Rd at Fox Ridge Road - AM (Site Folder: Mitigation)]

Output produced by SIDRA INTERSECTION Version: 9.1.4.221

Future Year 2041 Preferred AM Peak Hour - Mitigation

Site Category: NA

Roundabout

Vehicle Movement Performance														
Mov ID	Turn	Mov Class	Demand Flows		Arrival Flows		Deg. Satn	Aver. Delay	Level of Service	95% Back Of Queue	Prop. Que	Eff. Stop Rate	Aver. No. of Cycles	Aver. Speed
			[Total HV]	%	[Total HV]	%	v/c	sec		[Veh.]	[Dist]			mph
			veh/h		veh/h					veh	ft			
South: Hill Rd														
3	L2	All MCs	41	0.0	41	0.0	0.422	6.8	LOS A	2.8	70.3	0.35	0.16	34.7
8	T1	All MCs	476	2.0	476	2.0	0.422	7.0	LOS A	2.8	70.3	0.35	0.16	35.3
Approach			517	1.8	517	1.8	0.422	7.0	LOS A	2.8	70.3	0.35	0.16	35.2
North: Hill Rd														
4	T1	All MCs	394	4.0	394	4.0	0.341	5.7	LOS A	2.0	52.5	0.20	0.06	36.0
14	R2	All MCs	41	0.0	41	0.0	0.341	5.4	LOS A	2.0	52.5	0.20	0.06	36.2
Approach			436	3.6	436	3.6	0.341	5.7	LOS A	2.0	52.5	0.20	0.06	36.0
West: Fox Ridge Rd														
5	L2	All MCs	99	0.0	99	0.0	0.206	6.0	LOS A	0.9	23.4	0.53	0.40	33.8
12	R2	All MCs	88	0.0	88	0.0	0.206	6.0	LOS A	0.9	23.4	0.53	0.40	34.3
Approach			187	0.0	187	0.0	0.206	6.0	LOS A	0.9	23.4	0.53	0.40	34.0
All Vehicles			1139	2.2	1139	2.2	0.422	6.3	LOS A	2.8	70.3	0.32	0.16	35.3

Site Level of Service (LOS) Method: Delay & v/c (HCM 6). Site LOS Method is specified in the Parameter Settings dialog (Options tab).

Roundabout LOS Method: Same as Sign Control.

Vehicle movement LOS values are based on average delay and v/c ratio (degree of saturation) per movement.

LOS F will result if v/c > 1 irrespective of movement delay value (does not apply for approaches and intersection).

Intersection and Approach LOS values are based on average delay for all movements (v/c not used as specified in HCM 6).

Roundabout Capacity Model: US HCM 6.

Delay Model: HCM Delay Formula (Stopline Delay: Geometric Delay is not included).

Queue Model: SIDRA queue estimation methods are used for Back of Queue and Queue at Start of Gap.

Gap-Acceptance Capacity Formula: Siegloch M1 implied by US HCM 6 Roundabout Capacity Model.

HV (%) values are calculated for All Movement Classes of All Heavy Vehicle Model Designation.

Arrival Flows used in performance calculations are adjusted to include any Initial Queued Demand and Upstream Capacity Constraint effects.

SIDRA INTERSECTION 9.1 | Copyright © 2000-2023 Akcelik and Associates Pty Ltd | sidrasolutions.com

Organisation: DKS ASSOCIATES | Licence: PLUS / FLOATING | Processed: Monday, November 20, 2023 9:51:39 AM

Project: S:\Projects\2023\23041-000 (McMinnville Fox Ridge Area Plan TPR)\5_Analysis\SIDRA\Fox Ridge Road_Roundabout Analysis.sip9

MOVEMENT SUMMARY

Site: 2 [Hill Rd at 2nd Street - AM (Site Folder: Mitigation)]

Output produced by SIDRA INTERSECTION Version: 9.1.4.221

Future Year 2041 Preferred AM Peak Hour - Mitigation

Site Category: NA

Roundabout

Vehicle Movement Performance															
Mov ID	Turn	Mov Class	Demand Flows		Arrival Flows		Deg. Satn	Aver. Delay	Level of Service	95% Back Of Queue		Prop. Que	Eff. Stop Rate	Aver. No. of Cycles	Aver. Speed
			[Total HV]	%	[Total HV]	%				[Veh.]	Dist]				
			veh/h	%	veh/h	%	v/c	sec			ft				mph
South: Hill Rd															
3	L2	All MCs	39	10.0	39	10.0	0.627	17.6	LOS C	5.2	133.6	0.82	0.90	1.34	27.1
8	T1	All MCs	239	2.0	239	2.0	0.627	16.0	LOS C	5.2	133.6	0.82	0.90	1.34	28.5
18	R2	All MCs	161	5.0	161	5.0	0.627	16.6	LOS C	5.2	133.6	0.82	0.90	1.34	23.3
Approach			439	3.8	439	3.8	0.627	16.3	LOS C	5.2	133.6	0.82	0.90	1.34	26.2
East: 2nd St															
1	L2	All MCs	72	8.0	72	8.0	0.379	9.0	LOS A	1.9	49.2	0.60	0.44	0.60	26.5
6	T1	All MCs	117	3.0	117	3.0	0.379	8.3	LOS A	1.9	49.2	0.60	0.44	0.60	28.1
16	R2	All MCs	144	2.0	144	2.0	0.379	8.2	LOS A	1.9	49.2	0.60	0.44	0.60	28.6
Approach			333	3.7	333	3.7	0.379	8.4	LOS A	1.9	49.2	0.60	0.44	0.60	28.0
North: Hill Rd															
7	L2	All MCs	237	0.0	237	0.0	0.481	8.6	LOS A	3.0	77.2	0.57	0.35	0.57	26.1
4	T1	All MCs	199	5.0	199	5.0	0.481	9.1	LOS A	3.0	77.2	0.57	0.35	0.57	30.3
14	R2	All MCs	69	3.0	69	3.0	0.481	8.9	LOS A	3.0	77.2	0.57	0.35	0.57	31.5
Approach			504	2.4	504	2.4	0.481	8.8	LOS A	3.0	77.2	0.57	0.35	0.57	28.3
West: 2nd St															
5	L2	All MCs	106	2.0	106	2.0	0.522	11.9	LOS B	3.7	94.9	0.73	0.71	1.04	29.4
2	T1	All MCs	250	5.0	250	5.0	0.522	12.4	LOS B	3.7	94.9	0.73	0.71	1.04	29.9
12	R2	All MCs	39	10.0	39	10.0	0.522	13.3	LOS B	3.7	94.9	0.73	0.71	1.04	29.5
Approach			394	4.7	394	4.7	0.522	12.3	LOS B	3.7	94.9	0.73	0.71	1.04	29.7
All Vehicles			1671	3.6	1671	3.6	0.627	11.5	LOS B	5.2	133.6	0.68	0.60	0.89	28.0

Site Level of Service (LOS) Method: Delay & v/c (HCM 6). Site LOS Method is specified in the Parameter Settings dialog (Options tab).

Roundabout LOS Method: Same as Sign Control.

Vehicle movement LOS values are based on average delay and v/c ratio (degree of saturation) per movement.

LOS F will result if v/c > 1 irrespective of movement delay value (does not apply for approaches and intersection).

Intersection and Approach LOS values are based on average delay for all movements (v/c not used as specified in HCM 6).

Roundabout Capacity Model: US HCM 6.

Delay Model: HCM Delay Formula (Stopline Delay: Geometric Delay is not included).

Queue Model: SIDRA queue estimation methods are used for Back of Queue and Queue at Start of Gap.

Gap-Acceptance Capacity Formula: Siegloch M1 implied by US HCM 6 Roundabout Capacity Model.

HV (%) values are calculated for All Movement Classes of All Heavy Vehicle Model Designation.

Arrival Flows used in performance calculations are adjusted to include any Initial Queued Demand and Upstream Capacity Constraint effects.

SIDRA INTERSECTION 9.1 | Copyright © 2000-2023 Akcelik and Associates Pty Ltd | sidrasolutions.com

Organisation: DKS ASSOCIATES | Licence: PLUS / FLOATING | Processed: Monday, November 20, 2023 9:51:41 AM

Project: S:\Projects\2023\23041-000 (McMinnville Fox Ridge Area Plan TPR)\5_Analysis\SIDRA\Fox Ridge Road_Roundabout Analysis.sjp9

HCM Signalized Intersection Capacity Analysis

3: Fox Ridge Rd & Hill Rd

Fox Ridge Road Area Plan
Future 2041 Preferred Scenario AM Peak Hour - Mitigation





















Movement	EBL	EBR	NBL	NBT	SBT	SBR
Lane Configurations						
Traffic Volume (vph)	89	79	37	428	355	37
Future Volume (vph)	89	79	37	428	355	37
Ideal Flow (vphp)	1900	1900	1900	1900	1900	1900
Total Lost time (s)	5.0		5.0	5.0	5.0	
Lane Util. Factor	1.00		1.00	1.00	1.00	
Frpb, ped/bikes	1.00		1.00	1.00	1.00	
Flpb, ped/bikes	1.00		1.00	1.00	1.00	
Frt	0.94		1.00	1.00	0.99	
Flt Protected	0.97		0.95	1.00	1.00	
Satd. Flow (prot)	1733		1802	1863	1806	
Flt Permitted	0.97		0.48	1.00	1.00	
Satd. Flow (perm)	1733		906	1863	1806	
Peak-hour factor, PHF	0.90	0.90	0.90	0.90	0.90	0.90
Adj. Flow (vph)	99	88	41	476	394	41
RTOR Reduction (vph)	38	0	0	0	5	0
Lane Group Flow (vph)	149	0	41	476	430	0
Confl. Peds. (#/hr)	5		3			3
Heavy Vehicles (%)	0%	0%	0%	2%	4%	0%
Turn Type	Prot		Perm	NA	NA	
Protected Phases	4			2	6	
Permitted Phases			2			
Actuated Green, G (s)	9.7		20.3	20.3	20.3	
Effective Green, g (s)	9.7		20.3	20.3	20.3	
Actuated g/C Ratio	0.24		0.51	0.51	0.51	
Clearance Time (s)	5.0		5.0	5.0	5.0	
Vehicle Extension (s)	3.0		3.0	3.0	3.0	
Lane Grp Cap (vph)	420		459	945	916	
v/s Ratio Prot	c0.09			c0.26	0.24	
v/s Ratio Perm			0.05			
v/c Ratio	0.36		0.09	0.50	0.47	
Uniform Delay, d1	12.6		5.1	6.5	6.4	
Progression Factor	1.00		1.00	1.00	1.00	
Incremental Delay, d2	0.5		0.1	0.4	0.4	
Delay (s)	13.1		5.2	6.9	6.8	
Level of Service	B		A	A	A	
Approach Delay (s)	13.1			6.8	6.8	
Approach LOS	B			A	A	
Intersection Summary						
HCM 2000 Control Delay			7.8		HCM 2000 Level of Service	A
HCM 2000 Volume to Capacity ratio			0.46			
Actuated Cycle Length (s)			40.0		Sum of lost time (s)	10.0
Intersection Capacity Utilization			47.4%		ICU Level of Service	A
Analysis Period (min)			15			
c Critical Lane Group						

HCM Signalized Intersection Capacity Analysis

4: Hill Rd & 2nd St

Fox Ridge Road Area Plan

Future 2041 Preferred Scenario AM Peak Hour - Mitigation

												
Movement	EBL	EBT	EBR	WBL	WBT	WBR	NBL	NBT	NBR	SBL	SBT	SBR
Lane Configurations												
Traffic Volume (vph)	95	225	35	65	105	130	35	215	145	213	179	62
Future Volume (vph)	95	225	35	65	105	130	35	215	145	213	179	62
Ideal Flow (vphp)	1900	1900	1900	1900	1900	1900	1900	1900	1900	1900	1900	1900
Total Lost time (s)		5.0	5.0		5.0		5.0	5.0		5.0	5.0	
Lane Util. Factor		1.00	1.00		1.00		1.00	1.00		1.00	1.00	
Frbp, ped/bikes		1.00	0.98		0.99		1.00	0.99		1.00	1.00	
Flpb, ped/bikes		1.00	1.00		1.00		1.00	1.00		1.00	1.00	
Frt		1.00	0.85		0.94		1.00	0.94		1.00	0.96	
Flt Protected		0.99	1.00		0.99		0.95	1.00		0.95	1.00	
Satd. Flow (prot)		1797	1434		1690		1641	1713		1805	1748	
Flt Permitted		0.73	1.00		0.67		0.95	1.00		0.95	1.00	
Satd. Flow (perm)		1327	1434		1148		1641	1713		1805	1748	
Peak-hour factor, PHF	0.90	0.90	0.90	0.90	0.90	0.90	0.90	0.90	0.90	0.90	0.90	0.90
Adj. Flow (vph)	106	250	39	72	117	144	39	239	161	237	199	69
RTOR Reduction (vph)	0	0	27	0	31	0	0	27	0	0	13	0
Lane Group Flow (vph)	0	356	12	0	302	0	39	373	0	237	255	0
Confl. Peds. (#/hr)	2					2						
Confl. Bikes (#/hr)			3						4			
Heavy Vehicles (%)	2%	5%	10%	8%	3%	2%	10%	2%	5%	0%	5%	3%
Turn Type	Perm	NA	Perm	Perm	NA		Prot	NA		Prot	NA	
Protected Phases		4			8		5	2		1	6	
Permitted Phases	4		4	8								
Actuated Green, G (s)		24.4	24.4		24.4		3.1	23.6		14.1	34.6	
Effective Green, g (s)		24.4	24.4		24.4		3.1	23.6		14.1	34.6	
Actuated g/C Ratio		0.32	0.32		0.32		0.04	0.31		0.18	0.45	
Clearance Time (s)		5.0	5.0		5.0		5.0	5.0		5.0	5.0	
Vehicle Extension (s)		3.0	3.0		3.0		3.0	3.0		3.0	3.0	
Lane Grp Cap (vph)		419	453		363		65	524		330	784	
v/s Ratio Prot							0.02	c0.22		c0.13	0.15	
v/s Ratio Perm		c0.27	0.01		0.26							
v/c Ratio		0.85	0.03		0.83		0.60	0.71		0.72	0.32	
Uniform Delay, d1		24.6	18.2		24.4		36.4	23.7		29.6	13.7	
Progression Factor		1.00	1.00		1.00		1.00	1.00		1.00	1.00	
Incremental Delay, d2		14.8	0.0		14.8		14.0	4.5		7.3	0.2	
Delay (s)		39.5	18.2		39.3		50.4	28.3		36.9	14.0	
Level of Service		D	B		D		D	C		D	B	
Approach Delay (s)		37.4			39.3		30.2			24.7		
Approach LOS		D			D		C			C		
Intersection Summary												
HCM 2000 Control Delay			32.1				HCM 2000 Level of Service			C		
HCM 2000 Volume to Capacity ratio			0.77									
Actuated Cycle Length (s)			77.1				Sum of lost time (s)			15.0		
Intersection Capacity Utilization			82.9%				ICU Level of Service			E		
Analysis Period (min)			15									
c	Critical Lane Group											

MOVEMENT SUMMARY

Site: 1 [Hill Rd at Fox Ridge Road - PM (Site Folder: Mitigation)]

Output produced by SIDRA INTERSECTION Version: 9.1.4.221

Future Year 2041 Preferred PM Peak Hour - Mitigation

Site Category: NA

Roundabout

Vehicle Movement Performance															
Mov ID	Turn	Mov Class	Demand Flows		Arrival Flows		Deg. Satn	Aver. Delay	Level of Service	95% Back Of Queue	Prop. Que	Eff. Stop Rate	Aver. No. of Cycles	Aver. Speed	
			[Total HV]	%	[Total HV]	%	v/c	sec		[Veh.]	[Dist]			mph	
			veh/h		veh/h					veh	ft				
South: Hill Rd															
3	L2	All MCs	115	0.0	115	0.0	0.548	8.6	LOS A	4.5	113.4	0.41	0.17	0.41	33.6
8	T1	All MCs	565	2.0	565	2.0	0.548	8.7	LOS A	4.5	113.4	0.41	0.17	0.41	34.1
Approach			680	1.7	680	1.7	0.548	8.7	LOS A	4.5	113.4	0.41	0.17	0.41	34.0
North: Hill Rd															
4	T1	All MCs	613	1.0	613	1.0	0.609	10.1	LOS B	5.4	136.4	0.52	0.24	0.52	34.0
14	R2	All MCs	126	0.0	126	0.0	0.609	10.0	LOS A	5.4	136.4	0.52	0.24	0.52	33.8
Approach			740	0.8	740	0.8	0.609	10.1	LOS B	5.4	136.4	0.52	0.24	0.52	34.0
West: Fox Ridge Rd															
5	L2	All MCs	87	0.0	87	0.0	0.237	7.6	LOS A	1.0	25.8	0.62	0.54	0.62	33.1
12	R2	All MCs	87	0.0	87	0.0	0.237	7.6	LOS A	1.0	25.8	0.62	0.54	0.62	33.5
Approach			174	0.0	174	0.0	0.237	7.6	LOS A	1.0	25.8	0.62	0.54	0.62	33.3
All Vehicles			1593	1.1	1593	1.1	0.609	9.2	LOS A	5.4	136.4	0.48	0.24	0.48	33.9

Site Level of Service (LOS) Method: Delay & v/c (HCM 6). Site LOS Method is specified in the Parameter Settings dialog (Options tab).

Roundabout LOS Method: Same as Sign Control.

Vehicle movement LOS values are based on average delay and v/c ratio (degree of saturation) per movement.

LOS F will result if v/c > 1 irrespective of movement delay value (does not apply for approaches and intersection).

Intersection and Approach LOS values are based on average delay for all movements (v/c not used as specified in HCM 6).

Roundabout Capacity Model: US HCM 6.

Delay Model: HCM Delay Formula (Stopline Delay: Geometric Delay is not included).

Queue Model: SIDRA queue estimation methods are used for Back of Queue and Queue at Start of Gap.

Gap-Acceptance Capacity Formula: Siegloch M1 implied by US HCM 6 Roundabout Capacity Model.

HV (%) values are calculated for All Movement Classes of All Heavy Vehicle Model Designation.

Arrival Flows used in performance calculations are adjusted to include any Initial Queued Demand and Upstream Capacity Constraint effects.

SIDRA INTERSECTION 9.1 | Copyright © 2000-2023 Akcelik and Associates Pty Ltd | sidrasolutions.com

Organisation: DKS ASSOCIATES | Licence: PLUS / FLOATING | Processed: Monday, November 20, 2023 9:51:40 AM

Project: S:\Projects\2023\23041-000 (McMinnville Fox Ridge Area Plan TPR)\5_Analysis\SIDRA\Fox Ridge Road_Roundabout Analysis.sip9

MOVEMENT SUMMARY

Site: 2 [Hill Rd at 2nd Street - PM (Site Folder: Mitigation)]

Output produced by SIDRA INTERSECTION Version: 9.1.4.221

Future Year 2041 Preferred PM Peak Hour - Mitigation

Site Category: NA

Roundabout

Vehicle Movement Performance															
Mov ID	Turn	Mov Class	Demand Flows		Arrival Flows		Deg. Satn	Aver. Delay	Level of Service	95% Back Of Queue		Prop. Que	Eff. Stop Rate	Aver. No. of Cycles	Aver. Speed
			[Total HV] veh/h	%	[Total HV] veh/h	%				[Veh.] veh	[Dist] ft				
South: Hill Rd															
3	L2	All MCs	39	0.0	39	0.0	0.565	12.0	LOS B	4.7	120.6	0.75	0.72	1.09	28.7
8	T1	All MCs	340	3.0	340	3.0	0.565	12.5	LOS B	4.7	120.6	0.75	0.72	1.09	29.9
18	R2	All MCs	89	4.0	89	4.0	0.565	12.7	LOS B	4.7	120.6	0.75	0.72	1.09	24.3
Approach			468	2.9	468	2.9	0.565	12.5	LOS B	4.7	120.6	0.75	0.72	1.09	28.5
East: 2nd St															
1	L2	All MCs	117	3.0	117	3.0	0.728	18.7	LOS C	9.1	230.0	0.89	1.06	1.61	23.8
6	T1	All MCs	222	1.0	222	1.0	0.728	18.4	LOS C	9.1	230.0	0.89	1.06	1.61	25.1
16	R2	All MCs	258	1.0	258	1.0	0.728	18.4	LOS C	9.1	230.0	0.89	1.06	1.61	25.6
Approach			597	1.4	597	1.4	0.728	18.5	LOS C	9.1	230.0	0.89	1.06	1.61	25.0
North: Hill Rd															
7	L2	All MCs	199	1.0	199	1.0	0.736	17.2	LOS C	10.9	275.6	0.88	0.90	1.55	23.9
4	T1	All MCs	341	2.0	341	2.0	0.736	17.4	LOS C	10.9	275.6	0.88	0.90	1.55	27.5
14	R2	All MCs	134	0.0	134	0.0	0.736	17.1	LOS C	10.9	275.6	0.88	0.90	1.55	28.5
Approach			674	1.3	674	1.3	0.736	17.3	LOS C	10.9	275.6	0.88	0.90	1.55	26.5
West: 2nd St															
5	L2	All MCs	101	0.0	101	0.0	0.404	10.5	LOS B	2.1	53.7	0.71	0.67	0.85	29.9
2	T1	All MCs	156	1.0	156	1.0	0.404	10.7	LOS B	2.1	53.7	0.71	0.67	0.85	30.4
12	R2	All MCs	22	0.0	22	0.0	0.404	10.5	LOS B	2.1	53.7	0.71	0.67	0.85	30.2
Approach			279	0.6	279	0.6	0.404	10.6	LOS B	2.1	53.7	0.71	0.67	0.85	30.2
All Vehicles			2018	1.6	2018	1.6	0.736	15.6	LOS C	10.9	275.6	0.83	0.87	1.36	27.0

Site Level of Service (LOS) Method: Delay & v/c (HCM 6). Site LOS Method is specified in the Parameter Settings dialog (Options tab).

Roundabout LOS Method: Same as Sign Control.

Vehicle movement LOS values are based on average delay and v/c ratio (degree of saturation) per movement.

LOS F will result if v/c > 1 irrespective of movement delay value (does not apply for approaches and intersection).

Intersection and Approach LOS values are based on average delay for all movements (v/c not used as specified in HCM 6).

Roundabout Capacity Model: US HCM 6.

Delay Model: HCM Delay Formula (Stopline Delay: Geometric Delay is not included).

Queue Model: SIDRA queue estimation methods are used for Back of Queue and Queue at Start of Gap.

Gap-Acceptance Capacity Formula: Siegloch M1 implied by US HCM 6 Roundabout Capacity Model.

HV (%) values are calculated for All Movement Classes of All Heavy Vehicle Model Designation.

Arrival Flows used in performance calculations are adjusted to include any Initial Queued Demand and Upstream Capacity Constraint effects.

SIDRA INTERSECTION 9.1 | Copyright © 2000-2023 Akcelik and Associates Pty Ltd | sidrasolutions.com

Organisation: DKS ASSOCIATES | Licence: PLUS / FLOATING | Processed: Monday, November 20, 2023 9:51:41 AM

Project: S:\Projects\2023\23041-000 (McMinnville Fox Ridge Area Plan TPR)\5_Analysis\SIDRA\Fox Ridge Road_Roundabout Analysis.sjp9

HCM Signalized Intersection Capacity Analysis

3: Fox Ridge Rd & Hill Rd

Fox Ridge Road Area Plan
 Future 2041 Preferred Scenario PM Peak Hour - Mitigation



Movement	EBL	EBR	NBL	NBT	SBT	SBR
Lane Configurations						
Traffic Volume (vph)	80	80	105	514	558	115
Future Volume (vph)	80	80	105	514	558	115
Ideal Flow (vphp)	1900	1900	1900	1900	1900	1900
Total Lost time (s)	4.5		4.5	4.5	4.5	
Lane Util. Factor	1.00		1.00	1.00	1.00	
Frpb, ped/bikes	1.00		1.00	1.00	1.00	
Flpb, ped/bikes	1.00		1.00	1.00	1.00	
Frt	0.93		1.00	1.00	0.98	
Flt Protected	0.98		0.95	1.00	1.00	
Satd. Flow (prot)	1729		1805	1863	1834	
Flt Permitted	0.98		0.28	1.00	1.00	
Satd. Flow (perm)	1729		531	1863	1834	
Peak-hour factor, PHF	0.91	0.91	0.91	0.91	0.91	0.91
Adj. Flow (vph)	88	88	115	565	613	126
RTOR Reduction (vph)	42	0	0	0	9	0
Lane Group Flow (vph)	134	0	115	565	730	0
Confl. Bikes (#/hr)						2
Heavy Vehicles (%)	0%	0%	0%	2%	1%	0%
Turn Type	Prot		Perm	NA	NA	
Protected Phases	4			2	6	
Permitted Phases			2			
Actuated Green, G (s)	9.3		30.2	30.2	30.2	
Effective Green, g (s)	9.3		30.2	30.2	30.2	
Actuated g/C Ratio	0.19		0.62	0.62	0.62	
Clearance Time (s)	4.5		4.5	4.5	4.5	
Vehicle Extension (s)	3.0		3.0	3.0	3.0	
Lane Grp Cap (vph)	331		330	1160	1141	
v/s Ratio Prot	c0.08			0.30	c0.40	
v/s Ratio Perm			0.22			
v/c Ratio	0.40		0.35	0.49	0.64	
Uniform Delay, d1	17.2		4.4	5.0	5.7	
Progression Factor	1.00		1.00	1.00	1.00	
Incremental Delay, d2	0.8		0.6	0.3	1.2	
Delay (s)	18.0		5.0	5.3	6.9	
Level of Service	B		A	A	A	
Approach Delay (s)	18.0			5.2	6.9	
Approach LOS	B			A	A	

Intersection Summary			
HCM 2000 Control Delay	7.4	HCM 2000 Level of Service	A
HCM 2000 Volume to Capacity ratio	0.58		
Actuated Cycle Length (s)	48.5	Sum of lost time (s)	9.0
Intersection Capacity Utilization	62.8%	ICU Level of Service	B
Analysis Period (min)	15		

c Critical Lane Group

HCM Signalized Intersection Capacity Analysis
4: Hill Rd & 2nd St

Fox Ridge Road Area Plan
Future 2041 Preferred Scenario PM Peak Hour - Mitigation



Movement	EBL	EBT	EBR	WBL	WBT	WBR	NBL	NBT	NBR	SBL	SBT	SBR		
Lane Configurations		↖	↗		↔		↖	↗		↖	↗			
Traffic Volume (vph)	91	140	20	105	200	232	35	306	80	179	307	121		
Future Volume (vph)	91	140	20	105	200	232	35	306	80	179	307	121		
Ideal Flow (vphpl)	1900	1900	1900	1900	1900	1900	1900	1900	1900	1900	1900	1900		
Total Lost time (s)		5.0	5.0		5.0		5.0	5.0		5.0	5.0			
Lane Util. Factor		1.00	1.00		1.00		1.00	1.00		1.00	1.00			
Frbp, ped/bikes		1.00	0.97		1.00		1.00	1.00		1.00	0.99			
Flpb, ped/bikes		1.00	1.00		1.00		1.00	1.00		1.00	1.00			
Frt		1.00	0.85		0.94		1.00	0.97		1.00	0.96			
Flt Protected		0.98	1.00		0.99		0.95	1.00		0.95	1.00			
Satd. Flow (prot)		1852	1573		1746		1805	1775		1787	1783			
Flt Permitted		0.59	1.00		0.83		0.95	1.00		0.95	1.00			
Satd. Flow (perm)		1113	1573		1456		1805	1775		1787	1783			
Peak-hour factor, PHF	0.90	0.90	0.90	0.90	0.90	0.90	0.90	0.90	0.90	0.90	0.90	0.90		
Adj. Flow (vph)	101	156	22	117	222	258	39	340	89	199	341	134		
RTOR Reduction (vph)	0	0	13	0	32	0	0	11	0	0	15	0		
Lane Group Flow (vph)	0	257	9	0	565	0	39	418	0	199	460	0		
Confl. Peds. (#/hr)			2	2										
Confl. Bikes (#/hr)			2						3			2		
Heavy Vehicles (%)	0%	1%	0%	3%	1%	1%	0%	3%	4%	1%	2%	0%		
Turn Type	Perm	NA	Perm	Perm	NA		Prot	NA		Prot	NA			
Protected Phases		4			8		5	2		1	6			
Permitted Phases	4		4	8										
Actuated Green, G (s)		35.0	35.0		35.0		2.8	25.4		11.1	33.7			
Effective Green, g (s)		35.0	35.0		35.0		2.8	25.4		11.1	33.7			
Actuated g/C Ratio		0.40	0.40		0.40		0.03	0.29		0.13	0.39			
Clearance Time (s)		5.0	5.0		5.0		5.0	5.0		5.0	5.0			
Vehicle Extension (s)		3.0	3.0		3.0		3.0	3.0		3.0	3.0			
Lane Grp Cap (vph)		450	636		589		58	521		229	694			
v/s Ratio Prot							0.02	c0.24		c0.11	0.26			
v/s Ratio Perm		0.23	0.01		c0.39									
v/c Ratio		0.57	0.01		0.96		0.67	0.80		0.87	0.66			
Uniform Delay, d1		19.9	15.4		25.1		41.4	28.2		37.0	21.7			
Progression Factor		1.00	1.00		1.00		1.00	1.00		1.00	1.00			
Incremental Delay, d2		1.8	0.0		27.3		26.6	8.7		27.6	2.4			
Delay (s)		21.7	15.4		52.4		68.0	37.0		64.6	24.1			
Level of Service		C	B		D		E	D		E	C			
Approach Delay (s)		21.2			52.4			39.5			36.1			
Approach LOS		C			D			D			D			
Intersection Summary														
HCM 2000 Control Delay			39.6									HCM 2000 Level of Service	D	
HCM 2000 Volume to Capacity ratio			0.89											
Actuated Cycle Length (s)			86.5							15.0				
Intersection Capacity Utilization			90.7%										ICU Level of Service	E
Analysis Period (min)			15											
c	Critical Lane Group													

TRAVEL DEMAND MODEL OUTPUTS & ODOT CORRESPONDENCE

To: Arielle Ferber, ODOT R2
Cc: Alex Bettinardi, ODOT TPAU
From: Jenna Bogert, DKS Associates
Date: September 19th, 2023

Proposed Future Forecasts and Assumptions Fox Ridge Road Area Plan

DKS previously submitted a letter¹ that outlined the methodology for estimating the future 2044 Baseline volumes and 2044 Preferred Land Use Scenario volumes for the Fox Ridge Road Area Plan. This memo provides the detailed analysis assumptions including the proposed growth rate, trip generation rates, and trip distribution assumptions for the traffic study, based on data from the travel demand model which was provided by ODOT TPAU.

Proposed Growth Rate

ODOT TPAU provided volume figures from the 2015 and 2041 travel demand models to DKS. Based on the volume plots, the average yearly vehicle growth is approximately 4% per year on Hill Road. DKS will apply the growth rate of 4% linearly to the 2023 collected traffic count data to estimate future year 2044 Baseline traffic volumes at all study intersections.

Proposed Trip Generation Rates

ODOT TPAU provided the number of households (213) and the household trip generation rates for TAZ 252 (area west of NW Hill Road along Fox Ridge Road) from the travel demand model to DKS. DKS will use the trip generation rates (shown below) to estimate the number of vehicle trips generated by the residential units in the Preferred Land Use Scenario.

At the suggestion of ODOT TPAU, the trip generation for employees based in the Fox Ridge Road area should be calculated using trip generation rates from the Institute of Transportation Engineers (ITE) Trip Generation Manual or similar. This was recommended in lieu of developing a trip rate per job or trip rate per employee from the travel demand model. The ITE trip rates for retail are shown in the table below.

Land Use	Daily Trip Rate	AM Trip Rate	PM Trip Rate	Source
Household	8.10 per DU	0.55 per DU	0.74 per DU	From McMinnville Travel Demand Model (ODOT TPAU)
Retail	54.45 per KSF	2.36 per KSF	6.59 per KSF	From ITE (LUC 822)

Proposed Trip Distribution

ODOT TPAU provided select zone plots for TAZ 252 and TAZ 139 from the travel demand model to DKS. The model plot for TAZ 252 shows the origin-destination routes for household trips to/from the Fox Ridge Road area. The model plot for TAZ 139 shows the origin-destination routes for household trips and employee trips to/from the area just east of Fox Ridge Road plan area. DKS estimated an average trip distribution as follows based on both model plots:

- 5% of trips via NW Baker Creek Road (west of city limits)
- 30% of trips via NW Baker Creek Road (east of NW Hill Rd)
- 15% of trips via NW Wallace Road
- 30% of trips via SW 2nd Street (east)
- 5% of trips via SW 2nd Street (west)
- 10% of trips via SW Fellows Street
- 5% of trips via SW Hill Road south of SW Fellows Street

¹ Letter provided via email to Arielle Ferber and Alex Bettinardi on July 21st, 2023.

2015 PM Peak Hour Volumes

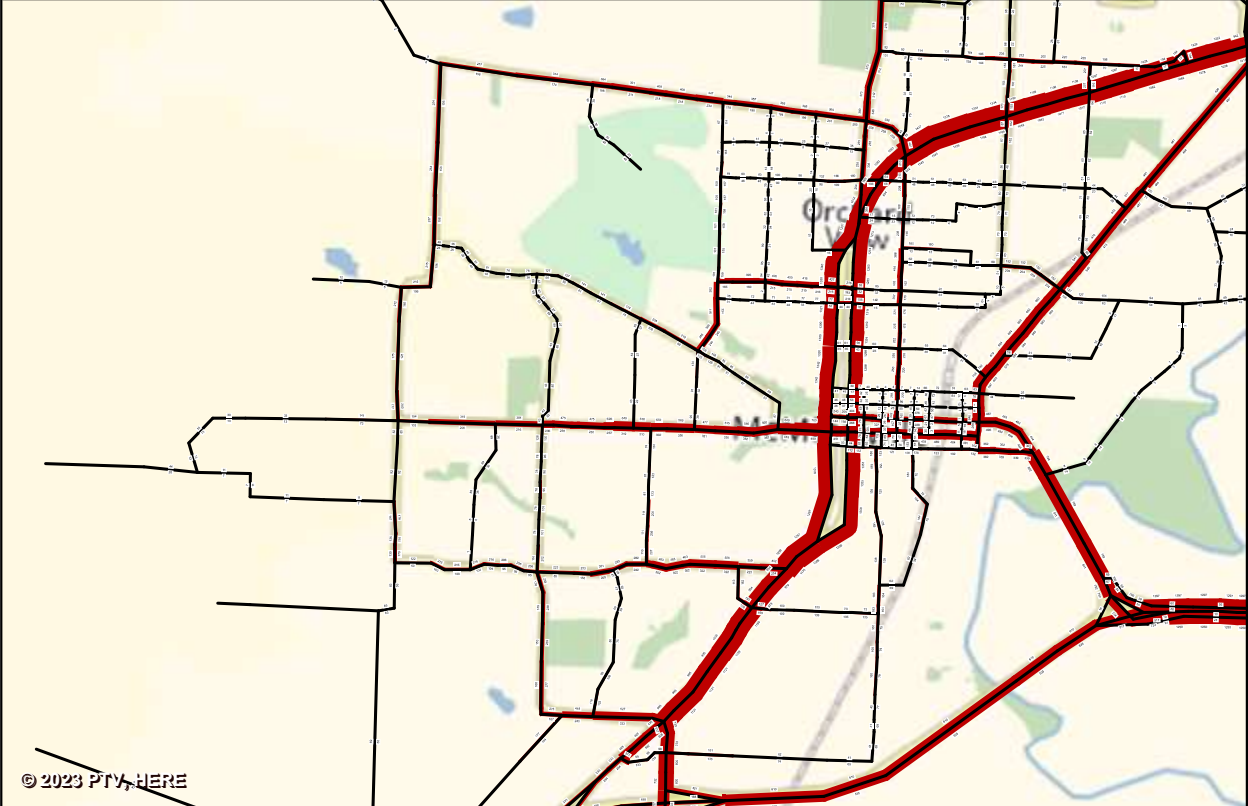

© 2023 PTW, HERE

2041 PM Peak Hour Volumes

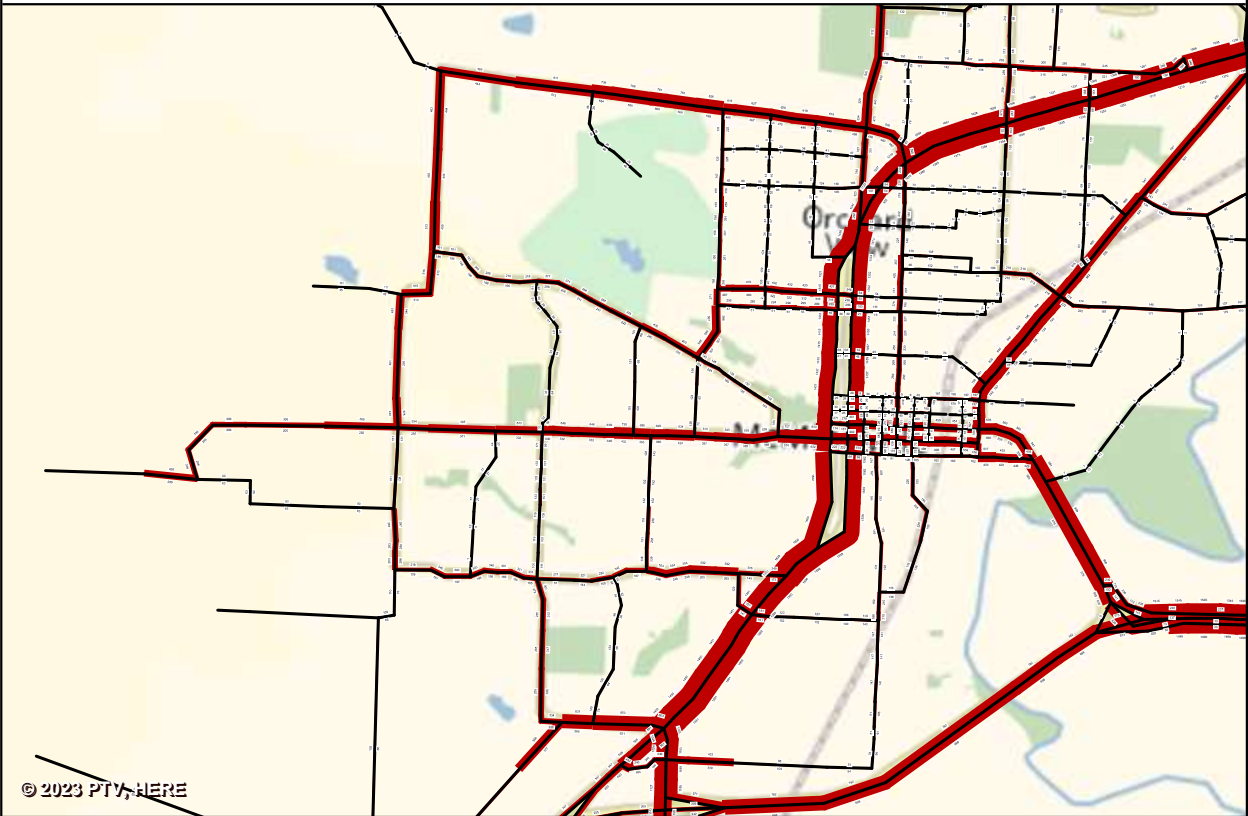

© 2023 PTV, HERE



Fox Ridge Road TPR Study - Future Volume Forecast Methodology

BETTINARDI Alexander O * Alex <Alexander.O.BETTINARDI@odot.oregon.gov>

To: Jenna Bogert <jenna.bogert@dksassociates.com>

Cc: FERBER Arielle <Arielle.FERBER@odot.oregon.gov>

Fox Ridge is represented by Zone 252

For the 2041 scenario, it's assumed to have 213 households (zero jobs), which are calculated to produce 2302 daily trips.

So on average each household in Zone 252 is generating 10.8 person vehicle trips / day.

Zone 252 generates 1716 vehicle trips per day at an average of 8.1 trips / day (this number is just vehicles – accounts for vehicle occupancy)

I believe this is what you need, but please let me know if you were looking for additional information that was not provided here.

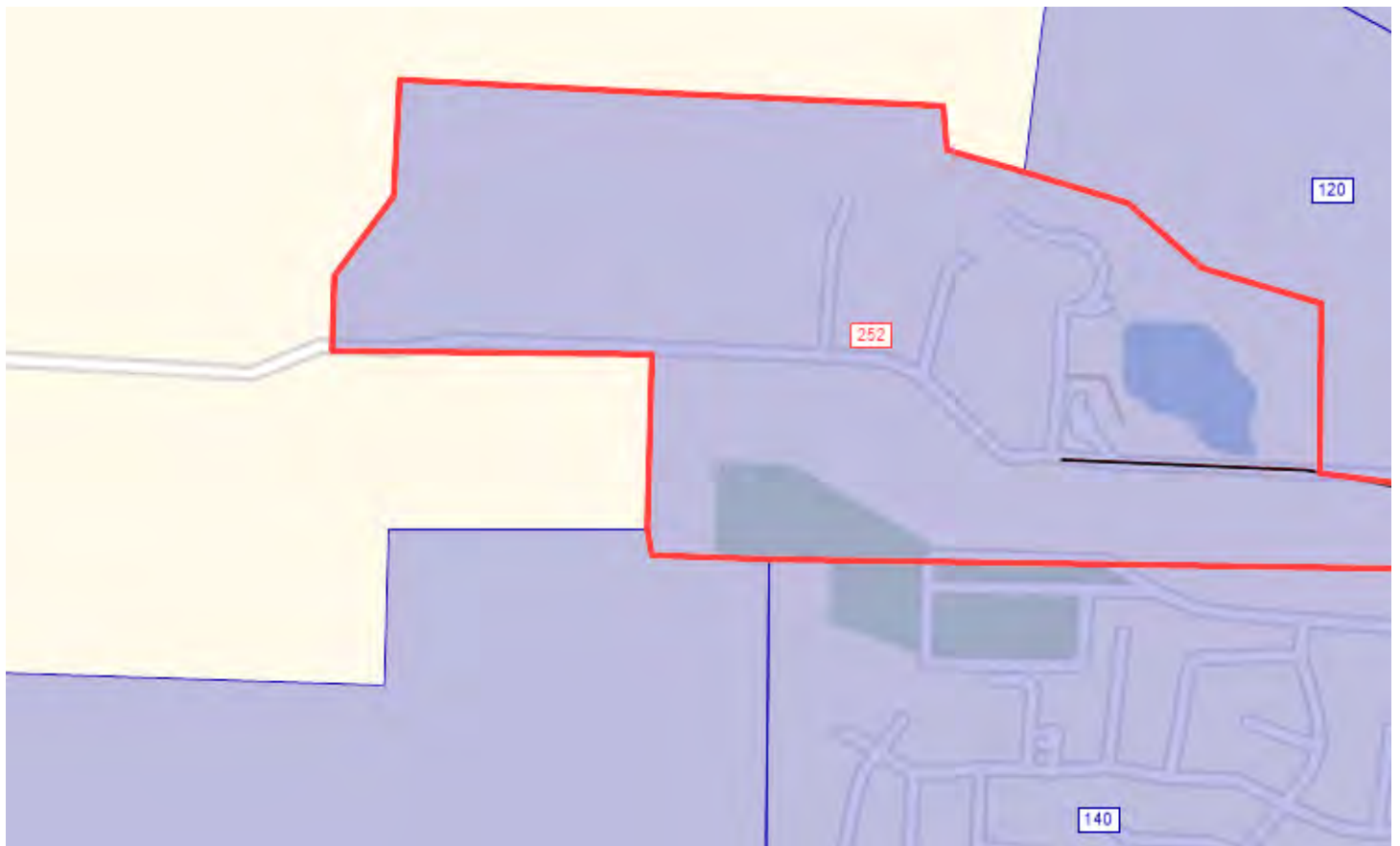

Alex Bettinardi, P.E. (he/him)

503.949.2368

<http://www.oregon.gov/ODOT/Planning/Pages/default.aspx>



Jenna Bogert <jenna.bogert@dksassociates.com>

Fox Ridge Road TPR Study - Future Volume Forecast Methodology

BETTINARDI Alexander O * Alex
<Alexander.O.BETTINARDI@odot.oregon.gov>

Thu, Aug 10,
2023 at 11:02
AM

To: Jenna Bogert <jenna.bogert@dksassociates.com>
Cc: FERBER Arielle <Arielle.FERBER@odot.oregon.gov>

Unfortunately, I don't think there's a good way to develop a trips per job or employee rate from the Model.

I was digging in and there are a couple of factors that I believe make creating a trip rate per employee unadvised:

- Trips in the model are produced by households – so it is cleaner to create a household rate factor. They are then attracted to a number of different types of locations – not just jobs.
- Since most zones have a mix of employees and other attractions it's very difficult to separate which trips are attracted to employment versus other attractions.
- One way around this is to find zones with just employment and see how many trips are attracted to those zones, however – the McMinnville model uses special generators. And the impact of that is that some zones get a trip boost and some give away trips to those boosts. So some zones with just employment attraction will show more than the average because of a special generator (or really attractor) applied and some don't – and so the presence of this special generator treatment makes it near impossible (and at least very impractical) to tease apart what the average employee attraction for the area might be.

So for employers – I'm suggesting you might turn to ITE trip generation or similar.

For the PM peak hour vehicle generation for zone 252. There are 157.5 PM peak trips for TAZ 252, across 213 households, so 0.74 vehicle trips per household in the PM peak.

I hope this is helpful, please let me know if further information is needed.

Alex Bettinardi, P.E. (he/him)

503.949.2368

<http://www.oregon.gov/ODOT/Planning/Pages/default.aspx>

From: Jenna Bogert <jenna.bogert@dksassociates.com>

Sent: Thursday, August 10, 2023 10:04 AM

To: BETTINARDI Alexander O * Alex <Alexander.O.BETTINARDI@odot.oregon.gov>

Cc: FERBER Arielle <Arielle.FERBER@odot.oregon.gov>

Subject: Re: Fox Ridge Road TPR Study - Future Volume Forecast Methodology

This message was sent from outside the organization. Treat attachments, links and requests with caution. Be conscious of the information you share if you respond.

Alex - Can you provide the same household trip gen info for the PM peak hour in zone 252?

Also, can you provide the trips per job for the PM peak hour from another TAZ? Maybe TAZ 151?

Thanks!

Jenna Bogert, PE (OR, WA) | Transportation Engineering Associate
Direct Ph: 971-332-5316 | Email: jenna.bogert@dksassociates.com

[Quoted text hidden]

[Quoted text hidden]



Jenna Bogert <jenna.bogert@dksassociates.com>

Fox Ridge Road TPR Study - Future Volume Forecast Methodology

BETTINARDI Alexander O * Alex <Alexander.O.BETTINARDI@odot.oregon.gov>

Tue, Aug 22, 2023 at 10:50 AM

To: Jenna Bogert <jenna.bogert@dksassociates.com>

Do you think these will work (PM peak select zones)

Again, zone 252 is fox ridge. In the future year (these are future year) it has zero employment and 213 households

Zone 139 is the zone just to the east of 252. It has 193 households and 516 employment (61 retail and 444 service employees).

Alex Bettinardi, P.E. (he/him)

503.949.2368

<http://www.oregon.gov/ODOT/Planning/Pages/default.aspx>

From: Jenna Bogert <jenna.bogert@dksassociates.com>

Sent: Friday, August 18, 2023 2:24 PM

To: BETTINARDI Alexander O * Alex <Alexander.O.BETTINARDI@odot.oregon.gov>

Subject: Re: Fox Ridge Road TPR Study - Future Volume Forecast Methodology

This message was sent from outside the organization. Treat attachments, links and requests with caution. Be conscious of the information you share if you respond.

Hi Alex,

It was nice to meet you this week at the conference and hear all of your questions during the sessions!

As we briefly discussed on Tuesday morning, would you be able to run a select zone for the Fox Ridge Road TAZ 252? As well as a neighboring zone that also has employment trips? That way I can attempt to capture any differences in trip distribution between the two trip generators. I'll be summarizing all of the final assumptions in a report to Arielle and you in the next few weeks for final buy off.

Thanks and have a good weekend!
Jenna

Jenna Bogert, PE (OR, WA) | Transportation Engineering Associate
Direct Ph: 971-332-5316 | Email: jenna.bogert@dksassociates.com

Flow Bundles

Link bars

Volume flow bundle PrT [veh] (AP)

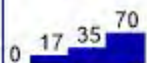

Zones

Chart

 Origin traffic flow bundle PrT [veh] (AP)

 Destination traffic flow bundle PrT [veh] (AP)

Scaling

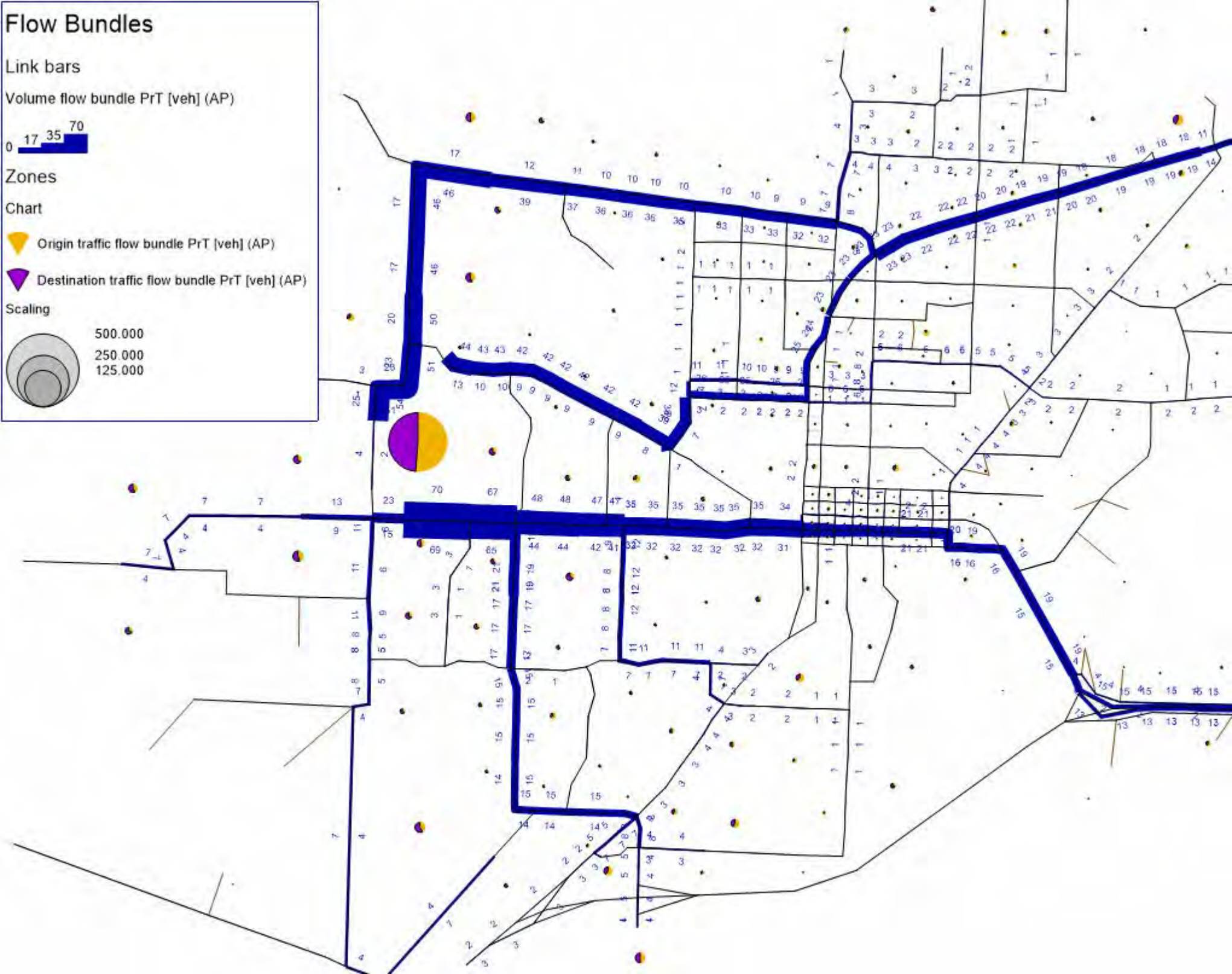

Flow Bundles

Link bars
Volume flow bundle PrT [veh] (AP)



Zones
Chart

- Origin traffic flow bundle PrT [veh] (AP)
- Destination traffic flow bundle PrT [veh] (AP)

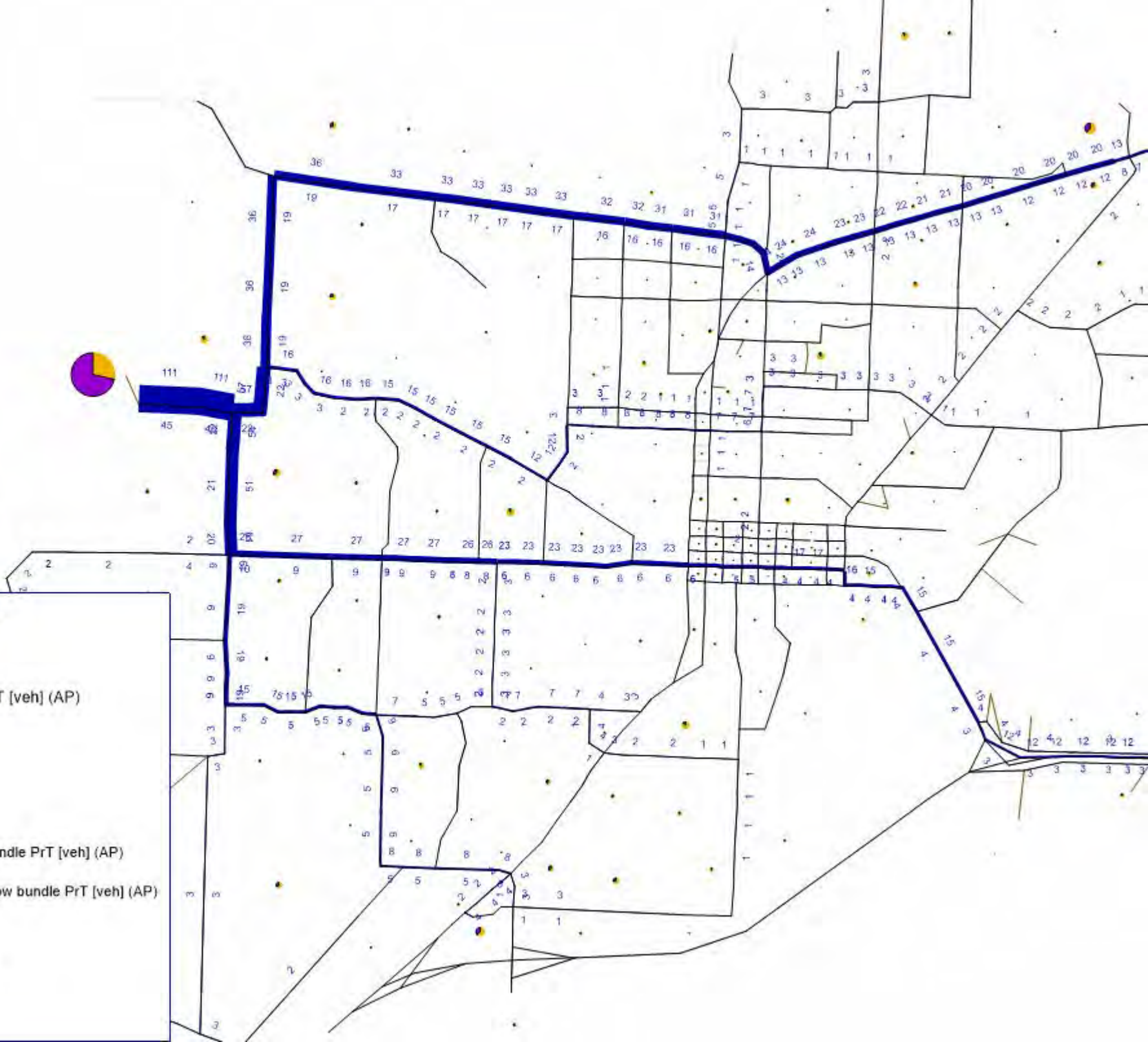
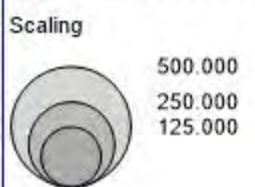

TRIP GENERATION VOLUME FIGURE

Trip Gen - AM

50

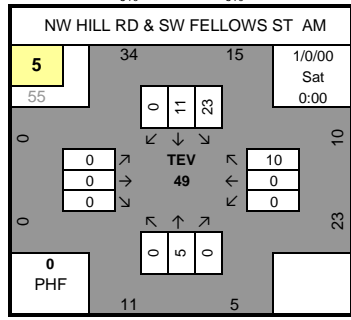
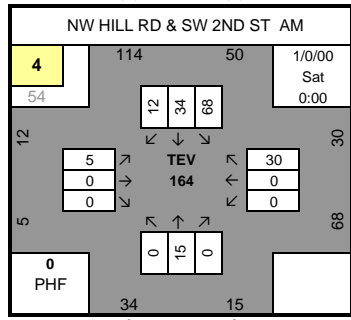
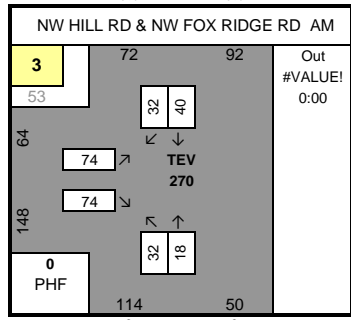
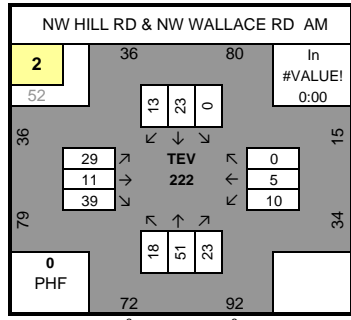
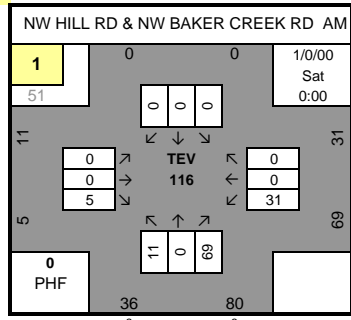

Trip Gen - PM

60

