



**CITY OF MCMINNVILLE
PLANNING DEPARTMENT**
231 NE FIFTH STREET
MCMINNVILLE, OR 97128

503-434-7311

www.mcminnvilleoregon.gov

DECISION, CONDITIONS, FINDINGS OF FACT AND CONCLUSIONARY FINDINGS OF THE MCMINNVILLE HISTORIC LANDMARKS COMMITTEE FOR THE APPROVAL OF AN ALTERED BUILDING AT 903 NE THIRD STREET WITHIN THE DOWNTOWN DESIGN AREA

DOCKET: DDR 5-19 (Downtown Design Review for Alterations including Waiver Request)

REQUEST: Approval of a Downtown Design Review application to allow for an addition to the existing building at 903 NE 3rd Street that infills the existing building perimeter walls under the existing covered area on the south side of the building. The proposed work includes alterations to the existing building façade as part of the addition, including new storefront windows, new façade materials, new awnings, and an updated fascia and cornice.

The application includes a request for one waiver from a downtown design standard to allow for a reduction in the amount of glazing (i.e. windows and other glass or openings) on the building facades from the required 70 percent to 61 percent on the Third Street façade and 44 percent on the new portion of the Irvine Street façade.

LOCATION: 903 NE 3rd Street. The property is identified as Tax Lot 4400, Section 21BD, T. 4 S., R. 4 W., W.M.

ZONING: C-3 (General Commercial)

APPLICANT: Ron Burcham, on behalf of property owner Mini Super Hidalgo LLC

STAFF: Chuck Darnell, Senior Planner

DATE DEEMED COMPLETE: October 17, 2019

DECISION-MAKING BODY & ACTION: McMinnville Historic Landmarks Committee

MEETING DATE & LOCATION: November 14, 2019, Community Development Center, 231 NE 5th Street, McMinnville, Oregon.

PROCEDURE: An application for a Downtown Design Review is processed in accordance with the procedures in Section 17.59.030(A) of the McMinnville Municipal Code.

CRITERIA: The applicable criteria for a Downtown Design Review are specified in Section 17.59.040 of the McMinnville Municipal Code. In addition, the goals, policies, and proposals in Volume II of the Comprehensive Plan are to be applied to all land use decisions as criteria for approval, denial, or modification of the proposed request. Goals and policies are mandated; all land use decisions must conform to the applicable goals and policies of Volume II. "Proposals" specified in Volume

It are not mandated, but are to be undertaken in relation to all applicable land use requests.

APPEAL: As specified in Section 17.59.030(E) of the McMinnville Municipal Code, the Historic Landmarks Committee’s decision may be appealed to the Planning Commission within fifteen (15) days of the date written notice of decision is mailed. The City’s final decision is subject to a 120 day processing timeline, including resolution of any local appeal.

COMMENTS: This matter was referred to the following public agencies for comment: McMinnville Fire Department, Police Department, Engineering Department, Building Department, Parks Department, City Manager, and City Attorney; McMinnville Water and Light; McMinnville School District No. 40; Yamhill County Public Works; Yamhill County Planning Department; Frontier Communications; Comcast; Northwest Natural Gas; and Oregon Department of Transportation. Their comments are provided in this document.

RECOMMENDATION

Based on the findings and conclusionary findings, the Historic Landmarks Committee finds the applicable criteria are satisfied with conditions and **APPROVES** the exterior design of the proposed new building at 903 NE 3rd Street (DDR 5-19).

//
RECOMMENDATION: APPROVAL WITH CONDITIONS
//

Historic Landmarks Committee: _____
Joan Drabkin, Chair

Date: _____

Planning Department: _____
Heather Richards, Planning Director

Date: _____

I. APPLICATION SUMMARY:

The applicant has provided information in their application narrative and findings (attached as Attachment 1) regarding the request under consideration. Staff has found the information provided to accurately reflect the current land use request, and excerpted portions are provided below to give context to the request, in addition to staff’s comments.

Subject Property & Request

The subject property is located at 903 NE 3rd Street. The property is identified as Tax Lot 4400, Section 21BD, T. 4 S., R. 4 W., W.M. ***See Vicinity Map (Figure 1) below.***

Figure 1. Vicinity Map

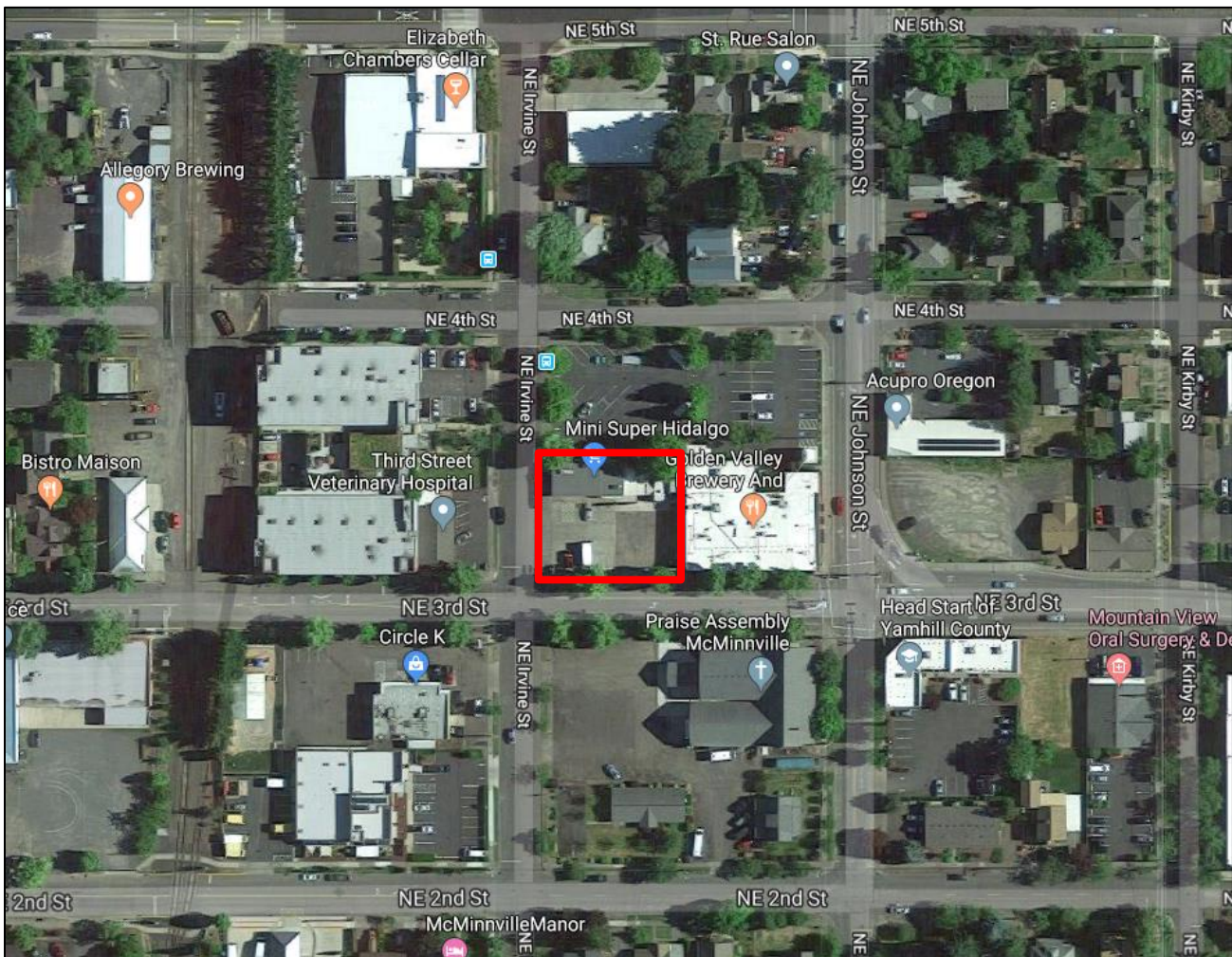

The applicant provided an overview of their proposal and project in the application narrative, which is as follows:

“Phase 1 is an addition under the existing roof (250 sf), infilling the existing building perimeter walls, and applying façade improvements per design standards. The total finished gross floor area will be 2020 sf.

Phase 2 design revisions continue, so design review will be separate applications. Phase 2 will be an addition that will include a permanent restaurant replacing the food wagon and storage, and improvements to the existing parking lot and site.

Architectural features include added storefront glazing, brick base on walls facing streets, new awning wrapping the street facing building walls, and an improved fascia with a new cornice trim.

The existing painted "stucco" finish on wood panels will be improved on street faces to match existing stucco on CMU, and the new "stucco" finish on new wood construction will be a thin coat texture system on wood sheathing or fiber-cement panels between new windows and at improved fascia. Some existing glazing is remaining unchanged."

Elevations and renderings of the street facing facades of the proposed new building are provided below. Full elevations and additional renderings are provided in the application materials (Attachment 1). **See Street Facing Elevations (Figure 2) and Building Rendering (Figure 3) below.**

Figure 2. Street Facing Elevations

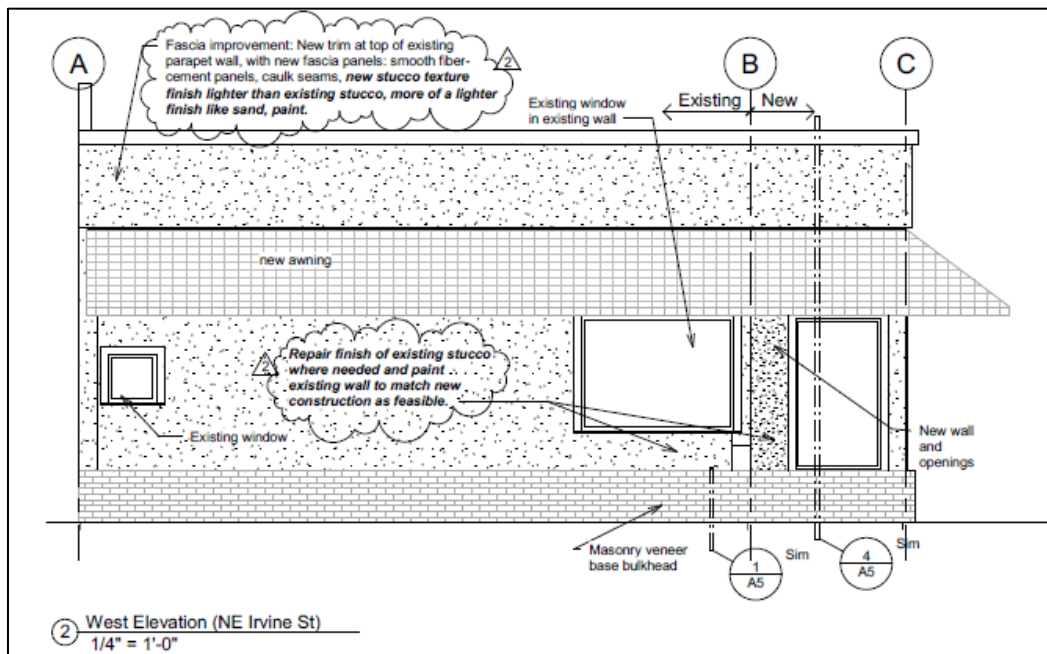
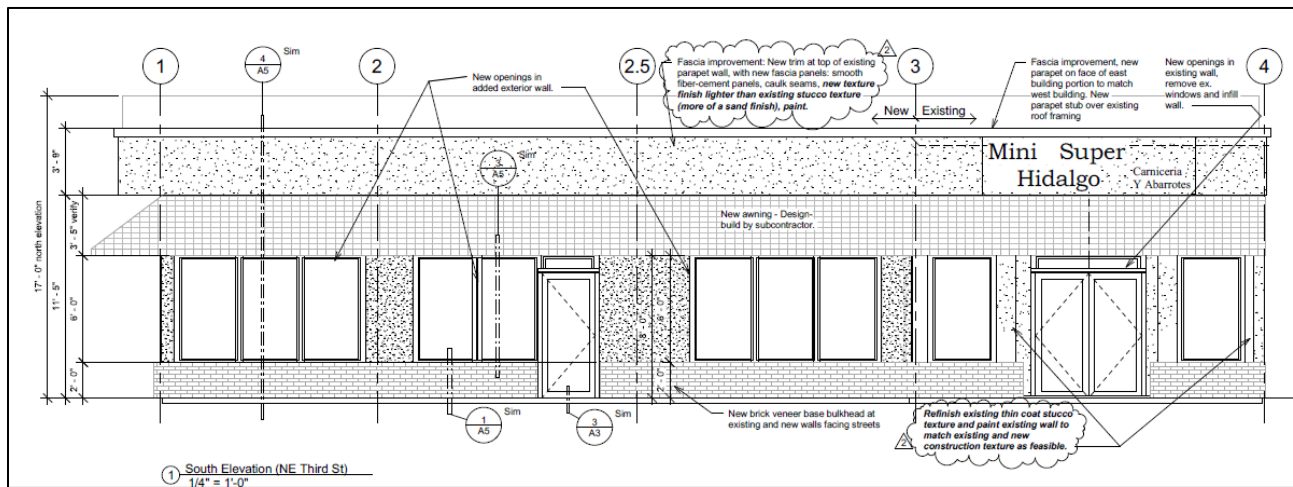

Attachments :

Attachment 1 – Application and Attachments

Figure 3. Building Rendering



Background

The property is located within the Downtown Design Standards and Guidelines area described in Chapter 17.59 of the McMinnville Municipal Code. The property and the existing buildings are not listed on the local Historic Resources Inventory or the McMinnville Downtown Historic District that is listed on the National Register of Historic Places. The property is located east of the historic district boundary, as shown below:

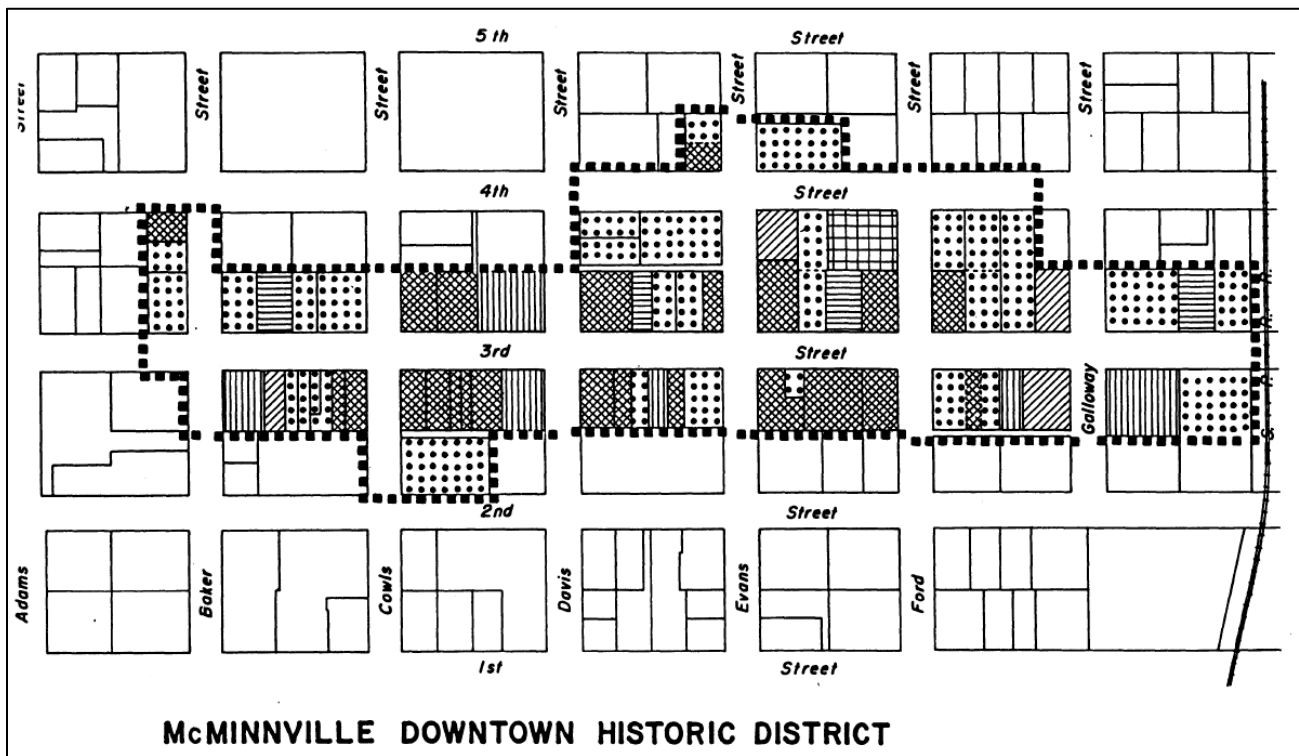

Summary of Criteria & Issues

Decisions and/or recommendations for approval of the land use application is dependent upon whether or not the application meets state regulations, the McMinnville Comprehensive Plan and the McMinnville Municipal Code. The application can either meet these criteria as proposed, or a condition of approval can be provided that either outlines what needs to occur to meet the criteria or when something needs to occur to meet the criteria.

The specific review criteria for Downtown Design Review for New Construction in Section 17.59.040 of the MMC require the proposal to be consistent with the applicable Downtown Design Standards and Guidelines in Chapter 17.59 of the MMC, as well as the following review criteria:

1. The City's historic preservation policies set forth in the Comprehensive Plan;
2. If a structure is designated as a historic landmark on the City's Historic Resources Inventory or is listed on the National Register for Historic Places, the City's historic preservation regulations in Chapter 17.65, and in particular, the standards and guidelines contained in Section 17.65.060(2);

In addition, any request for a waiver from a Downtown Design Standard is subject to the specific review criteria in Section 17.59.040(A)(3) of the MMC as follows:

- a. There is a demonstrable difficulty in meeting the specific requirements of this Chapter due to a unique or unusual aspect of the site, an existing structure, or proposed use of the site;
- b. There is demonstrable evidence that the alternative design accomplishes the purpose of this Chapter in a manner that is equal or superior to a project designed consistent with the standards contained herein; and
- c. The waiver requested is the minimum necessary to alleviate the difficulty of meeting the requirements of this Chapter.

The Planning Director has determined that the proposed construction activities are a major alteration to the building located in the Downtown Design Review Overlay District. Therefore, the alterations are subject to review criteria in Section 17.59.040 of the McMinnville Municipal Code. The application for the review of the exterior design of the new building includes a request from a waiver of one downtown design standard. Waiver requests are subject to the specific review criteria in Section 17.59.040(A)(3) of the McMinnville Municipal Code.

The specific waiver being requested is to allow for a reduction in the amount of glazing (i.e. windows and other glass or openings) on the building facades from the required 70 percent to 61 percent on the Third Street façade and 44 percent on the new portion of the Irvine Street façade.

In addition to the sections of the McMinnville Municipal Code referenced above, the goals and policies in Volume II of the Comprehensive Plan are also independent approval criteria for all land use decisions.

The applicant has provided findings to support the request for Downtown Design Review. These will be discussed in detail in Section VII (Conclusionary Findings) below.

II. CONDITIONS:

1. That the applicant shall submit building permit applications prior to completing any work. The construction plans submitted with the building permit applications will be reviewed by the Planning Director for consistency with the written narrative, exhibits, drawings, and renderings submitted for review by the Historic Landmarks Committee, along with any revisions to respond to other conditions of approval.

Attachments:

Attachment 1 – Application and Attachments

2. That the applicant shall provide a built example of the final exterior panel building material to be reviewed and approved by the Historic Landmarks Committee prior to the release of building permits for the proposed development. The built example shall include an example of the treatment of any seam that is to be caulked and painted over with the sand-textured paint.
3. That the applicant shall provide samples or examples of the exterior building colors to the Planning Department for review and approval by the Planning Director prior to application on the building.

III. ATTACHMENTS:

1. DDR 5-19 Application and Attachments (on file with the Planning Department)

IV. COMMENTS:

Agency Comments

This matter was referred to the following public agencies for comment: McMinnville Fire Department, Police Department, Parks and Recreation Department, Engineering and Building Departments, City Manager, and City Attorney, McMinnville School District No. 40, McMinnville Water and Light, Yamhill County Public Works, Yamhill County Planning Department, Recology Western Oregon, Frontier Communications, Comcast, Northwest Natural Gas. The following comments were received:

- McMinnville Fire Department

We have no issues with this request.

Public Comments

Notice of this request was mailed to property owners located within 100 feet of the subject site. As of the date of the Historic Landmarks Committee public meeting on November 14, 2019, no public testimony had been received by the Planning Department.

V. FINDINGS OF FACT - PROCEDURAL FINDINGS

1. The applicant, Ron Burcham, on behalf of property owner Mini Super Hidalgo LLC, submitted the Downtown Design Review application (DDR 4519) on October 1, 2019.
2. The application was deemed complete on October 17, 2019. Based on that date, the 120 day land use decision time limit expires on February 14, 2020.
3. Notice of the application was referred to the following public agencies for comment in accordance with Section 17.72.110 of the McMinnville Municipal Code: McMinnville Fire Department, Police Department, Parks and Recreation Department, Engineering and Building Departments, City Manager, and City Attorney, McMinnville School District No. 40, McMinnville Water and Light, Yamhill County Public Works, Yamhill County Planning Department, Recology Western Oregon, Frontier Communications, Comcast, Northwest Natural Gas.

Comments received from agencies are addressed in the Decision Document.

4. Notice of the application and the November 14, 2019 Historic Landmarks Committee public meeting was mailed to property owners within 100 feet of the subject property in accordance with Section 17.59.030(C)(3) and Section 17.72.110 of the McMinnville Municipal Code on October 29, 2019.

Attachments:

Attachment 1 – Application and Attachments

5. No public testimony was submitted to the Planning Department prior to the Historic Landmarks Committee public meeting.
6. On November 14, 2019, the Historic Landmarks Committee held a duly noticed public hearing to consider the request.

VI. FINDINGS OF FACT – GENERAL FINDINGS

1. **Location:** 903 NE 3rd Street. The property identified as Tax Lot 4400, Section 21BD, T. 4 S., R. 4 W., W.M.
2. **Size:** Approximately 12,000 square feet.
3. **Comprehensive Plan Map Designation:** Commercial
4. **Zoning:** C-3 (General Commercial)
5. **Overlay Zones/Special Districts:** Downtown Design Standards Area (per Section 17.59.020(A) of the McMinnville Municipal Code); Reduced Landscaping Requirements Area (per Section 17.57.080).
6. **Current Use:** Commercial – Retail and Restaurant
7. **Inventoried Significant Resources:**
 - a. **Historic Resources:** None
 - b. **Other:** None
8. **Other Features:** There are no significant or distinguishing natural features associated with this property.
9. **Utilities:**
 - a. **Water:** Water service is available to the subject site.
 - b. **Electric:** Power service is available to the subject site.
 - c. **Sewer:** Sanitary sewer service is available to the subject site.
 - d. **Stormwater:** Storm sewer service is available to the subject site.
 - e. **Other Services:** Other utility services are available to the subject site. Northwest Natural Gas and Comcast is available to serve the site.
10. **Transportation:** The site is bounded on the west by Irvine Street and on the south by 3rd Street. The McMinnville Transportation System Plan identifies 3rd Street as a major collector and Irvine Street as a local street. Section 17.53.101 of the McMinnville Municipal Code identifies the right-of-way width for these classifications of streets, but the site is within the downtown area with historic buildings constructed up to the property line. Therefore, no right-of-way dedication is required during the course of development of the properties in this area of the downtown.

VII. CONCLUSIONARY FINDINGS:

The Conclusionary Findings are the findings regarding consistency with the applicable criteria for the application. The applicable criteria for a Downtown Design Review request are specified in Section 17.59.040 of the Zoning Ordinance.

In addition, the goals, policies, and proposals in Volume II of the Comprehensive Plan are to be applied to all land use decisions as criteria for approval, denial, or modification of the proposed request. Goals and policies are mandated; all land use decisions must conform to the applicable goals and policies of

Attachments:

Attachment 1 – Application and Attachments

Volume II. “Proposals” specified in Volume II are not mandated, but are to be undertaken in relation to all applicable land use requests.

Comprehensive Plan Volume II:

The following Goals, Policies, and Proposals from Volume II of the Comprehensive Plan provide criteria applicable to this request:

The implementation of most goals, policies, and proposals as they apply to this application are accomplished through the provisions, procedures, and standards in the city codes and master plans, which are sufficient to adequately address applicable goals, policies, and proposals as they apply to this application.

The following additional findings are made relating to specific Goals and Policies:

GOAL III 2: TO PRESERVE AND PROTECT SITES, STRUCTURES, AREAS, AND OBJECTS OF HISTORICAL, CULTURAL, ARCHITECTURAL, OR ARCHAEOLOGICAL SIGNIFICANCE TO THE CITY OF McMINNVILLE.

APPLICANT’S RESPONSE: None.

FINDING: SATISFIED. The property and the existing buildings are not listed on the McMinnville Historic Resources Inventory or the McMinnville Downtown Historic District that is listed on the National Register of Historic Places.

GOAL IV 4: TO PROMOTE THE DOWNTOWN AS A CULTURAL, ADMINISTRATIVE, SERVICE, AND RETAIL CENTER OF McMINNVILLE

Downtown Development Policies:

Policy 36.00 The City of McMinnville shall encourage a land use pattern that:

- 1. Integrates residential, commercial, and governmental activities in and around the core of the city;*
- 2. Provides expansion room for commercial establishments and allows dense residential development;*
- 3. Provides efficient use of land for adequate parking areas;*
- 4. Encourages vertical mixed commercial and residential uses; and,*
- 5. Provides for a safe and convenient auto-pedestrian traffic circulation pattern.*

APPLICANT’S RESPONSE: None.

FINDING: SATISFIED. The proposal results in an expanded commercial establishment in the core of the city. The proposed structure is strictly commercial as a retail and restaurant uses. The existing improvements on the site include an off-street parking and internal vehicular circulation area. No changes are proposed to most areas of the site during the expansion of the existing commercial building, as the expansion will be infilling an existing covered area on the front of the building and not impacting any other portion of the site. The currently proposed building expansion does not prohibit further development or redevelopment of the site, which allows for more efficient use of land for development in the future. During the “Phase 2” improvements described by the applicant, additional site improvements may be required depending on the scale of the proposed future development of the site.

Policy 39.00 The City of McMinnville shall encourage and allow the development of pocket parks, landscaping, and other natural amenities to provide a visual contrast between streets and parking lots and buildings to enhance the general appearance of the downtown.

APPLICANT’S RESPONSE: None.

FINDING: SATISFIED. No changes are proposed to the parking and vehicular areas of the site during the expansion of the existing commercial building, as the expansion will be infilling an existing covered area on the front of the building and not impacting any other portion of the site. During the “Phase 2” improvements described by the applicant, additional site improvements may be required depending on the scale of the proposed future development of the site.

Policy 44.00 The City of McMinnville shall encourage, but not require, private businesses downtown to provide off-street parking and on-site traffic circulation for their employees and customers.

APPLICANT’S RESPONSE: None.

FINDING: SATISFIED. While not required, the proposal does include the retention of the existing off-street parking spaces for the existing commercial use.

Policy 46.01 The City shall, through its Landscape Review Committee, develop a list of street trees acceptable for planting within the public rights-of-way, parks and open spaces, and downtown. In addition, the committee shall develop standards for the planting of these trees, particularly within the downtown area, such that sidewalk and tree root conflicts are minimized. This effort should be coordinated with McMinnville Water and Light in an effort to minimize conflicts with utility lines.

APPLICANT’S RESPONSE: None.

FINDING: SATISFIED. No changes are proposed to most of the existing areas of the site during the expansion of the existing commercial building, as the expansion will be infilling an existing covered area on the front of the building and not impacting any other portion of the site. There are two existing street trees within the public right-of-way on Third Street, and those trees will not be impacted by the proposed building expansion. During the “Phase 2” improvements described by the applicant, additional on-site and off-site improvements may be required depending on the scale of the proposed future development of the site. This may include the planting of street trees within the public right-of-way.

GOAL X 1: TO PROVIDE OPPORTUNITIES FOR CITIZEN INVOLVEMENT IN THE LAND USE DECISION MAKING PROCESS ESTABLISHED BY THE CITY OF McMINNVILLE.

GOAL X 2: TO MAKE EVERY EFFORT TO ENGAGE AND INCLUDE A BROAD CROSS SECTION OF THE COMMUNITY BY MAINTAINING AN ACTIVE AND OPEN CITIZEN INVOLVEMENT PROGRAM THAT IS ACCESSIBLE TO ALL MEMBERS OF THE COMMUNITY AND ENGAGES THE COMMUNITY DURING DEVELOPMENT AND IMPLEMENTATION OF LAND USE POLICIES AND CODES.

Policy 188.00 The City of McMinnville shall continue to provide opportunities for citizen involvement in all phases of the planning process. The opportunities will allow for review and comment by community residents and will be supplemented by the availability of information on planning requests and the provision of feedback mechanisms to evaluate decisions and keep citizens informed.

APPLICANT’S RESPONSE: None.

Attachments:

Attachment 1 – Application and Attachments

FINDING: SATISFIED. The process for Downtown Design Review provides an opportunity for citizen involvement throughout the process through the public notice and the public meeting process. Throughout the process, there are opportunities for the public to review and obtain copies of the application materials and the completed staff report prior to the advertised public hearing(s). All members of the public have access to provide testimony and ask questions during the public review and hearing process.

McMinnville Zoning Ordinance

The following Sections of the McMinnville Zoning Ordinance (Ord. No. 3380) provide criteria applicable to the request:

Chapter 17.03. General Provisions

17.03.020 Purpose. The purpose of this ordinance is to encourage appropriate and orderly physical development in the City through standards designed to protect residential, commercial, industrial, and civic areas from the intrusions of incompatible uses; to provide opportunities for establishments to concentrate for efficient operation in mutually beneficial relationship to each other and to shared services; to provide adequate open space, desired levels of population densities, workable relationships between land uses and the transportation system, and adequate community facilities; to provide assurance of opportunities for effective utilization of the land resource; and to promote in other ways public health, safety, convenience, and general welfare.

APPLICANT’S RESPONSE: None.

FINDING: SATISFIED. The purpose of the Zoning Ordinance is met by the proposal as described in the Conclusionary Findings contained in this Decision Document.

17.59.020 Applicability.

- A. The provisions of this Chapter shall apply to all lands located within the area bounded to the west by Adams Street, to the north by 4th Street, to the east by Kirby Street, and to the south by 1st Street. Lands immediately adjacent to the west of Adams Street, from 1st Street to 4th Street, are also subject to the provisions of this Chapter.
- B. The provisions of this ordinance shall apply to the following activities conducted within the above described area:
 1. All new building construction;
 2. Any exterior building or site alteration; and,
 3. All new signage.

APPLICANT’S RESPONSE: None.

FINDING: SATISFIED. The subject site is located in the Downtown Design area. The proposal includes an addition to the existing building and complete new construction of the storefront and front building facades, so the provisions of the Downtown Design Standards and Guidelines chapter are applicable. Findings for the proposed alteration’s consistency with the applicable requirements of the Downtown Design Standards and Guidelines chapter are provided below.

17.59.030 Review Process.

- A. An application for any activity subject to the provisions of this ordinance shall be submitted to the Planning Department and shall be subject to the procedures listed in (B) through (E) below.
- B. Applications shall be submitted to the Planning Department for initial review for completeness as stated in Section 17.72.040. The application shall include the following information:

Attachments :

Attachment 1 – Application and Attachments

1. The applicant shall submit two (2) copies of the following information:
 - a. A site plan (for new construction or for structural modifications).
 - b. Building and construction drawings.
 - c. Building elevations of all visible sides.
 2. The site plan shall include the following information:
 - a. Existing conditions on the site including topography, streetscape, curbcuts, and building condition.
 - b. Details of proposed construction or modification to the existing structure.
 - c. Exterior building elevations for the proposed structure, and also for the adjacent structures.
 3. A narrative describing the architectural features that will be constructed and how they fit into the context of the Downtown Historic District.
 4. Photographs of the subject site and adjacent property.
 5. Other information deemed necessary by the Planning Director, or his/her designee, to allow review of the applicant's proposal. The Planning Director, or his/her designee, may also waive the submittal of certain information based upon the character and complexity (or simplicity) of the proposal.
- C. Review Process
1. Applications shall be submitted to the Planning Department for initial review for completeness as stated in Section 17.72.040. The Planning Director shall review the application and determine whether the proposed activity is in compliance with the requirements of this ordinance.
 2. The Planning Director may review applications for minor alterations subject to the review criteria stated in Section 17.59.040. The Historic Landmarks Committee shall review applications for major alterations and new construction, subject to the review criteria stated in Section 17.59.040. It shall be the Planning Director's decision as to whether an alteration is minor or major.
 3. Notification shall be provided for the review of applications for major alterations and new construction, subject to the provisions of Section 17.72.110.
 - a. The Historic Landmarks Committee shall meet within 30 (thirty) days of the date the application was deemed complete by the Planning Department. The applicant shall be notified of the time and place of the review and is encouraged to be present, although their presence shall not be necessary for action on the plans. A failure by the Planning Director or Historic Landmarks Committee, as applicable, to review within 30 (thirty) days shall be considered an approval of the application.
 - b. If the Planning Director or Historic Landmarks Committee, as applicable, finds the proposed activity to be in compliance with the provisions of this ordinance, they shall approve the application.
 - c. If the Planning Director or Historic Landmarks Committee, as applicable, finds the proposed activity in noncompliance with the provisions of this ordinance, they may deny the application, or approve it with conditions as may be necessary to bring the activity into compliance with this ordinance.

APPLICANT'S RESPONSE: None.

FINDING: SATISFIED WITH CONDITION #1. The applicant submitted an application as required, and the application was reviewed by the Historic Landmarks Committee because the Planning Director determined that the proposed construction activity consisted of major alterations to the existing building on the site. Notification was provided to property owners within 100 feet of the subject site, and the Historic Landmarks Committee met within 30 days of the date the application was deemed complete. A condition of approval is included to ensure that the eventual building construction is consistent with what was reviewed and approved by the Historic Landmarks Committee. The condition requires that the applicant submit building permit applications prior to completing any work, and that the construction plans submitted with

the building permit applications will be reviewed by the Planning Director for consistency with the written narrative, exhibits, drawings, and renderings submitted for review by the Historic Landmarks Committee, along with any revisions to respond to other conditions of approval.

17.59.040 Review Criteria

- A. In addition to the guidelines and standards contained in this ordinance, the review body shall base their decision to approve, approve with conditions, or deny the application, on the following criteria:
1. The City's historic preservation policies set forth in the Comprehensive Plan;
 2. If a structure is designated as a historic landmark on the City's Historic Resources Inventory or is listed on the National Register for Historic Places, the City's historic preservation regulations in Chapter 17.65, and in particular, the standards and guidelines contained in Section 17.65.060(2); and

APPLICANT'S RESPONSE: Note – See responses and findings provided to individual Comprehensive Plan policies above.

FINDING: SATISFIED. The proposal is consistent with the City's historic preservation policies in the Comprehensive Plan, as described in more detail in the findings for those Comprehensive Plan policies above. The subject site and existing buildings on the site are not designated as historic landmarks or resources on the McMinnville Historic Resources Inventory, and the property is outside of the McMinnville Downtown Historic District that is listed on the National Register of Historic Places. Therefore, the City's historic preservation regulations are not applicable to this request.

Glazing Waiver on 3rd Street Façade – Waiver from Section 17.59.050(B)(3)(c)

3. If applicable (waiver request), that all of the following circumstances are found to exist:
 - a. There is demonstrable difficulty in meeting the specific requirements of this Chapter due to a unique or unusual aspect of the site, an existing structure, or proposed use of the site;

APPLICANT'S RESPONSE: There is a demonstrable difficulty in meeting the glazing requirements of this Chapter due to the existing structure. The existing original structure is unreinforced masonry walls (concrete block) supporting an existing wood heavy-frame roof system. The existing roof framing system divides the existing building into structural bays which affect the new window placement.

The existing east addition is a wood frame structure that will have new openings added to the Third St. façade for a new recessed entry, and new windows.

New wall construction is to be 2x6 wood frame, with three new steel columns and foundations supporting the existing roof beams. The new wall facing Third St. will have new openings, however, a new shear wall is required along this new wall, and it needs to be located with a new column under an existing roof beam. The 5'-6" wide shear wall shown is the minimal length required to improve the existing structure along gridline C. Except for the shear wall, there are small parts of solid wall separating sets of windows.

FINDING: SATISFIED. The City concurs with the applicant's findings, and adds that the applicant provided roof framing plans that identify the proposed construction methods of the addition. The roof of the addition is proposed to be extended off of the existing building's roof framing system, necessitating the three new columns and foundations described by the applicant in the newly constructed south building wall. The roof framing plan can be seen below:

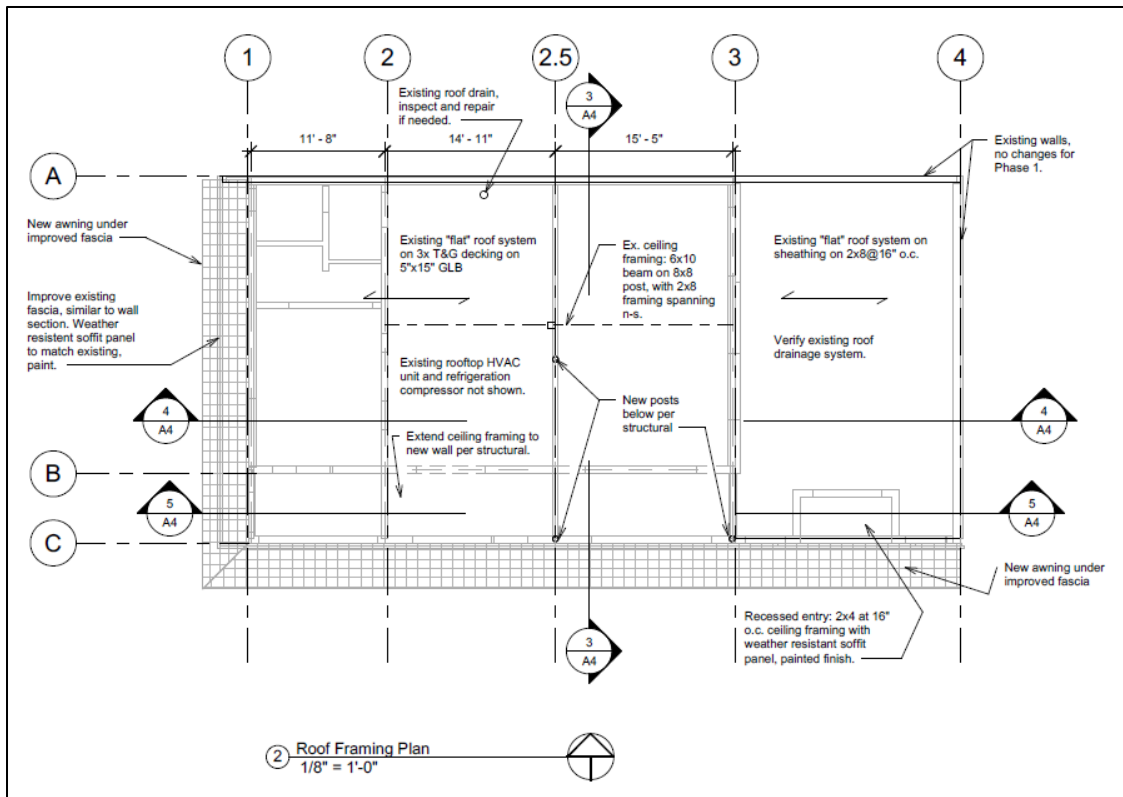

- b. There is demonstrable evidence that the alternative design accomplishes the purpose of this Chapter in a manner that is equal or superior to a project designed consistent with the standards contained herein; and

APPLICANT’S RESPONSE: The original Third St. façade has 32% glazing below 8'. The proposed new glazing will be 61% of wall area below 8', a significant glazing improvement over the existing façade, but less than the 70% required in the design standards.

The new and existing Third St. and Irvine St facades will include a 24" brick veneer bulkhead (required by design standards). This height is common on other Third St. buildings downtown, and will help protect the new large windows from deliveries and foot traffic along the building façade.

The new window and door openings along the Third St. new construction façade are grouped in proportional bays aligned with the existing roof beams bearing on the new wall. The narrow portions of walls between the window groups will appear to vertically divide the bays.

The proposed alternate design is consistent with the design standards. [...]

This project will have significantly more glazing facing Third St. than the existing building, new masonry veneer wall base, and a continuous awning, all of which will help this retailer fit into the downtown historic district. It will also fit better with nearby buildings with extensively glazed street facades.

The new pedestal sign at the street corner, replacing an existing pole sign, will fit the historic district patterns.

The new work proposed with this project will serve to help extend the historic downtown design standards further east along Third St.

FINDING: SATISFIED. The City concurs with the applicant’s findings. The City adds that the existing building does not meet a number of the Downtown Design Standards and Guidelines, and the new proposed building façade is proposed to meet all but the minimum glazing percentage, as described in the findings for each individual standard below.

- c. The waiver requested is the minimum necessary to alleviate the difficulty of meeting the requirements of this Chapter.

APPLICANT’S RESPONSE: Due to the structural requirements of the existing building, this waiver is requesting the minimum glazing change necessary to alleviate the difficulty of meeting the design standards for glazing.

FINDING: SATISFIED. The City concurs with the applicant’s findings.

Glazing Waiver on Irvine Street Façade – Waiver from Section 17.59.050(B)(3)(c)

3. If applicable (waiver request), that all of the following circumstances are found to exist:
 - a. There is demonstrable difficulty in meeting the specific requirements of this Chapter due to a unique or unusual aspect of the site, an existing structure, or proposed use of the site;

APPLICANT’S RESPONSE: The existing Irvine St. façade has no proposed changes to the existing glazing (15%), and the new portion of the Irvine St. façade is only 6' long, to fit under the existing roof. There are minimal changes to the interior layout along this façade, and the interior layout of the existing and new space does not work with an exterior door along Irvine St.

FINDING: SATISFIED. The City concurs with the applicant’s findings, but adds that the difficulty presented by the applicant is that the design of the addition is largely based on the existing, nonconforming (in terms of Downtown Design Standards) building that does not present an opportunity to effectively meet the minimum glazing requirement on the new portion of the Irvine Street façade. The interior floor plan is retaining the existing exterior building wall on the southwest portion of the building to continue to function as a secure office area with teller windows opening to the new corridor created with the building addition. The floor plan can be seen below:

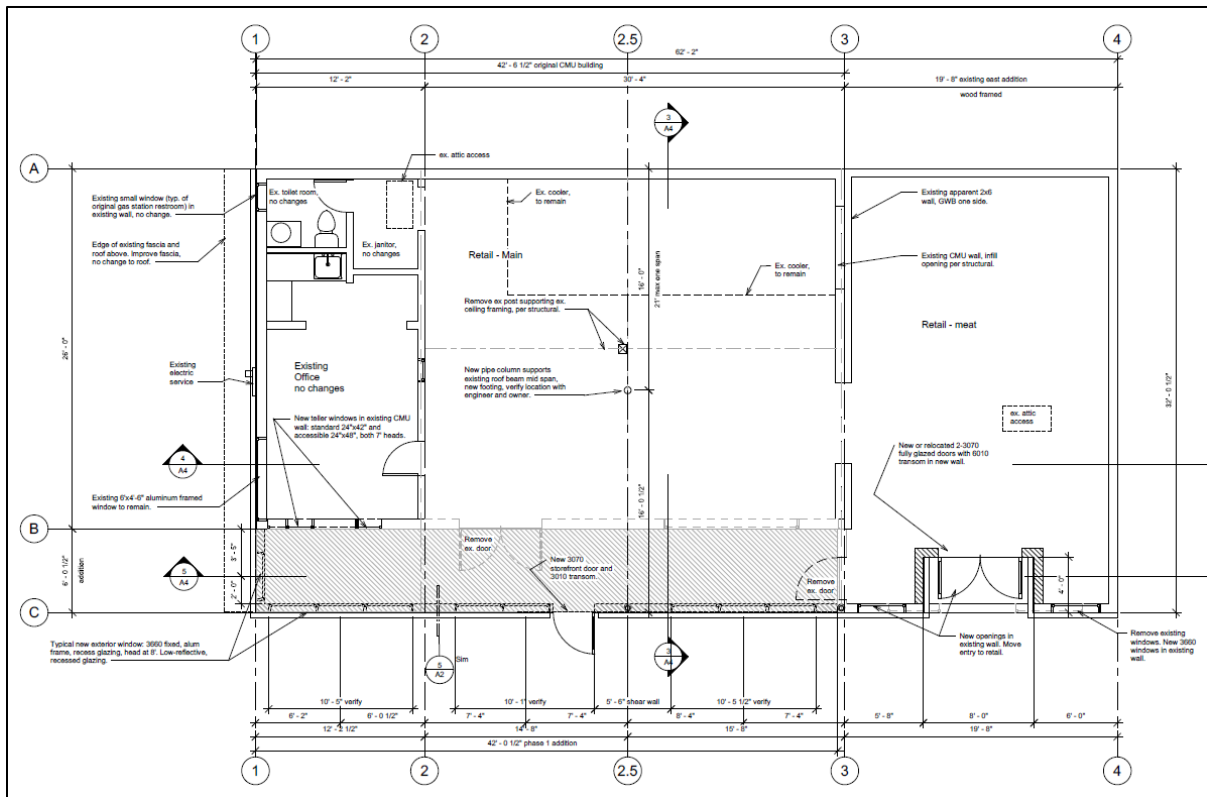

The approximately six foot additional wall surface will include one window of a size consistent with the size of the windows being proposed along the entire new south building wall, which provides consistency along the new portions of the building on both the Third Street and Irvine Street façades.

- b. There is demonstrable evidence that the alternative design accomplishes the purpose of this Chapter in a manner that is equal or superior to a project designed consistent with the standards contained herein; and

APPLICANT’S RESPONSE: The proposed new construction along Irvine St. facade is 6' long (fitting under existing roof), with a new window that matches the new Third St. façade windows. Matching the new window sizes in new construction for this corner facade is good design.

There will be a 2' brick veneer bulkhead required by design standards.

There will be 44% glazing in this minimal new wall. The entire west wall will be improved from 15% to an overall 20% glazing.

The proposed new alternate design is consistent with the design standards, considering existing conditions. [...]

This project will have significantly more glazing facing Third St. than the existing building, new masonry veneer wall base, and a continuous awning, all of which will help this retailer fit into the downtown historic district. It will also fit better with nearby buildings with extensively glazed street facades.

The new pedestal sign at the street corner, replacing an existing pole sign, will fit the historic district patterns.

The new work proposed with this project will serve to help extend the historic downtown design standards further east along Third St.

FINDING: SATISFIED. The City concurs with the applicant’s findings. The City adds that the existing building does not meet a number of the Downtown Design Standards and Guidelines, and the new proposed building façade is proposed to meet all but the minimum glazing percentage, as described in the findings for each individual standard below. The City also adds that the proposed alternative design, while not adding windows or additional glazing to the existing portion of the Irvine Street façade, is incorporating new building façade elements that meet the Downtown Design Standards. This includes improved fascia and cornice, a new awning extending along the entire façade at a consistent height, and a new masonry veneer bulkhead between the sidewalk grade and the base of the new windows being included in the addition’s wall. The existing and proposed Irvine Street façades, showing these proposed improvements, can be seen below:

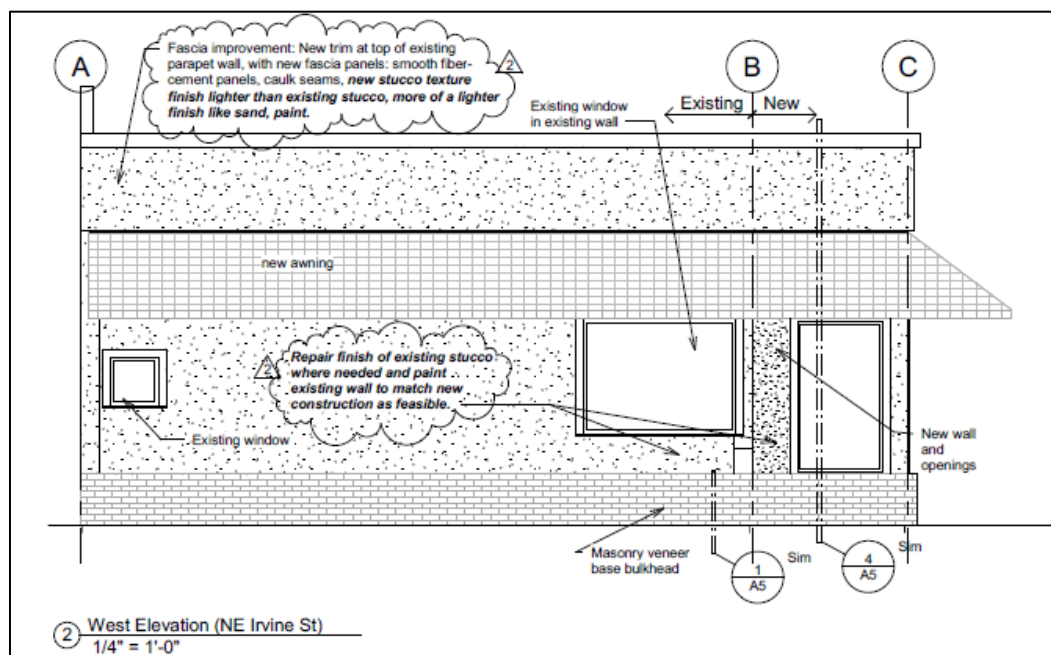

Attachments :

Attachment 1 – Application and Attachments

- c. The waiver requested is the minimum necessary to alleviate the difficulty of meeting the requirements of this Chapter.

APPLICANT’S RESPONSE: Due to the minimal new construction along the Irvine St. facade, this waiver is requesting the minimum glazing change necessary to alleviate the difficulty of meeting the design standards for glazing.

FINDING: SATISFIED. The City concurs with the applicant’s findings, and adds that the proposed 44 percent glazing in the new six feet of building wall is based on the design matching the proposed design along the entire south (Third Street facing) façade to maintain consistency in design and appearance along all public facing building façades.

17.59.050 Building and Site Design.

A. Building Setback.

1. Except as allowed by this ordinance, buildings shall maintain a zero setback from the sidewalk or property line.

APPLICANT’S RESPONSE: Existing building setback is maintained. Proposed new construction is an infill of an existing building gap under the existing roof, and it aligns with existing building facades facing both Third and Irvine Streets. Minimal new construction will be along Irvine; the existing exterior wall is less than 2’ from the Irvine property line, so new construction aligns with existing exterior wall.

The proposed new construction will reduce existing non-conformity.

FINDING: SATISFIED. The City concurs with the applicant’s findings, given that the proposed addition is an infill within existing building lines and the infill of an existing covered area on the south side of the building.

17.59.050 Building and Site Design

B. Building Design.

1. Buildings should have massing and configuration similar to adjacent or nearby historic buildings on the same block. Buildings situated at street corners or intersections should be, or appear to be, two-story in height.

APPLICANT’S RESPONSE: Existing single story building massing is not going to be substantially changed by project, proposed addition is an infill of an existing building gap under the existing roof, and it aligns with existing building exterior walls.

Existing building exterior walls do not align with nearby buildings.

(Phase 2 preliminary design option considered a new building at corner of Third and Irving Streets, but location and condition are unknown of existing underground gas tanks. The gas tanks were decommissioned in 1990 by filling with concrete grout, per receipts in file, and DEQ 1989 permit. The ports were located by surveyor. A new building would require a long foundation over the existing underground tank likely locations. It is not feasible to locate a new 2-story building at the street corner property lines.)

FINDING: SATISFIED. The City concurs with the applicant’s findings, given that the proposed addition is an infill within existing building lines and the infill of an existing covered area on the south side of the building.

17.59.050 Building and Site Design

B. Building Design. [...]

Attachments:

Attachment 1 – Application and Attachments

2. Where buildings will exceed the historical sixty feet in width, the façade should be visually subdivided into proportional bays, similar in scale to other adjacent historic buildings, and as appropriate to reflect the underlying historic property lines. This can be done by varying roof heights, or applying vertical divisions, materials and detailing to the front façade.

APPLICANT’S RESPONSE: The existing building is 62’ wide along Third St, and 32’ along Irving St. The façade improvements (grouped windows, new recessed entry, brick base, awning, fascia along existing parapet) are along the existing building street facing perimeter. A recessed doorway provides visual subdivision. The proposed new awning is continuous. The new windows facing Third St. are grouped in proportional bays, and walls between the window groups will appear to vertically divide the bays.

FINDING: SATISFIED. Staff concurs with the applicant’s findings. The proposed south (Third Street facing) façade can be seen below, with the proportional bays and vertical divisions identified. The vertical divisions appear in the form of solid building walls, which are shown in the locations required for support columns under the expanded roof framing system.

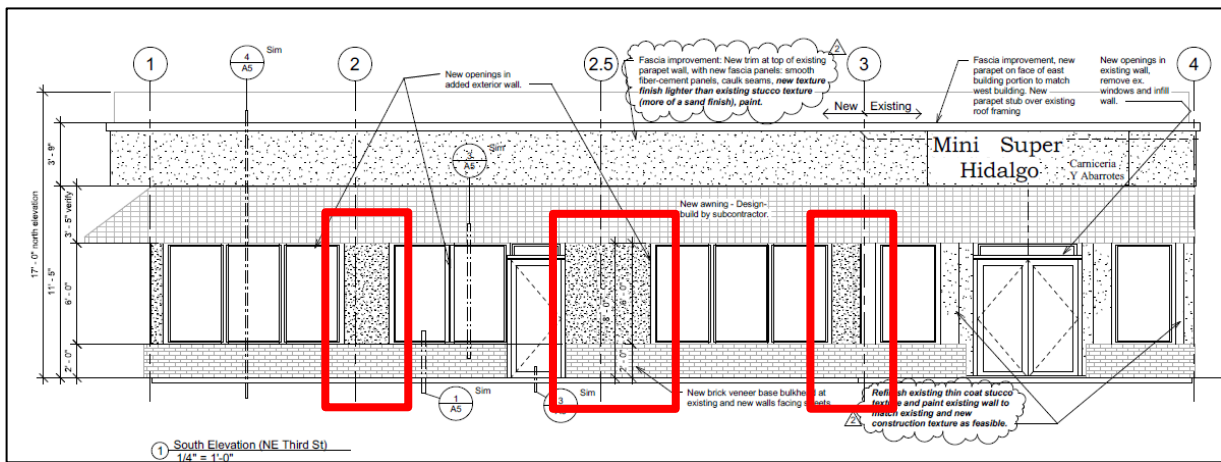

17.59.050 Building and Site Design

B. Building Design. [...]

3. Storefronts (that portion of the building that faces a public street) should include the basic features of a historic storefront, to include:
 - a. A belt course separating the upper stories from the first floor;

APPLICANT’S RESPONSE: The "storefront" improvements facing a public street are single story.

FINDING: SATISFIED. The City concurs with the applicant’s findings.

17.59.050 Building and Site Design

B. Building Design. [...]

3. Storefronts (that portion of the building that faces a public street) should include the basic features of a historic storefront, to include: [...]
 - b. A bulkhead at the street level;

APPLICANT’S RESPONSE: A new 24" brick veneer bulkhead is proposed at both Third and Irvine street facades at the street level.

FINDING: SATISFIED. The City concurs with the applicant’s findings. The brick bulkhead proposed can be seen below:

Attachments :

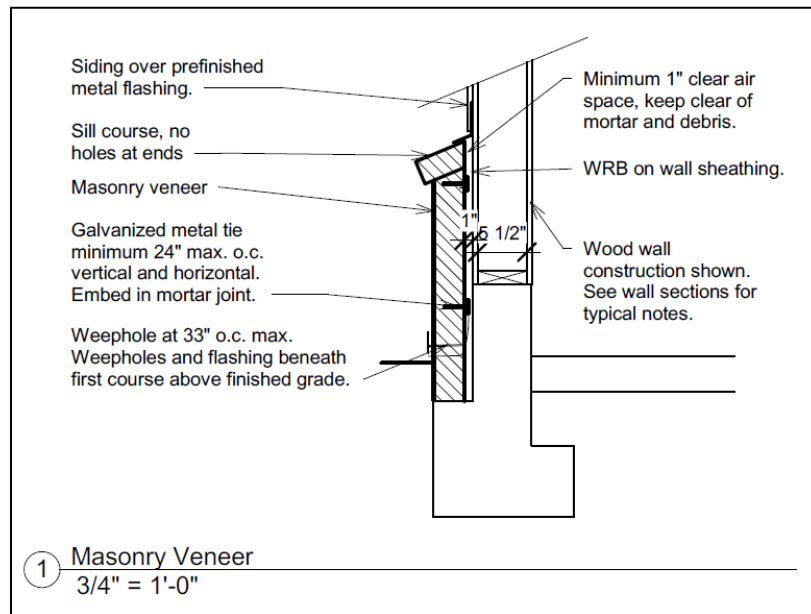
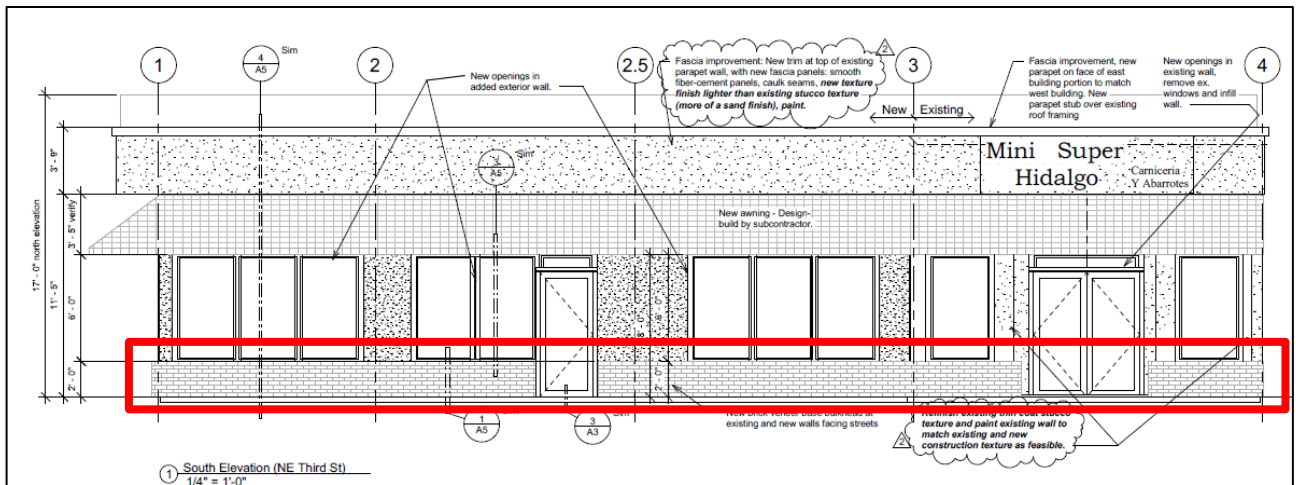

17.59.050 Building and Site Design

B. Building Design. [...]

3. Storefronts (that portion of the building that faces a public street) should include the basic features of a historic storefront, to include: [...]

- c. A minimum of seventy (70) percent glazing below the transom line of at least eight feet above the sidewalk, and forty (40) percent glazing below the horizontal trim band between the first and second stories. For the purposes of this section, glazing shall include both glass and openings for doorways, staircases and gates;

APPLICANT’S RESPONSE: Glazing below the transom line of 8', applied to new construction:

- o Third St. new construction and remodel:
 - o wall area below 8': 497 sf
 - o original wall glazing area 32%
 - o new glazing area 61%.
 - o Waiver requested.
- o Irvine St. new wall construction - wall area 48 sf; new glazing area 44%. Waiver requested.
- o Irvine St. existing wall construction - Wall area 208 sf; original glazing area 15%. No changes proposed, not applicable.

Attachments :

Attachment 1 – Application and Attachments

FINDING: SATISFIED. Findings for the waiver described by the applicant are provided in the findings for the waiver review criteria above.

17.59.050 Building and Site Design

B. Building Design. [...]

- 3. Storefronts (that portion of the building that faces a public street) should include the basic features of a historic storefront, to include: [...]
 - d. A recessed entry and transom with transparent door; and

APPLICANT’S RESPONSE: Third St: A new recessed entry and transom with transparent door is provided at Third St. façade.

Irvine St: The new exterior façade wall along Irvine St. is minimal (6' long) with minor interior alterations. The interior layout of the existing and new space does not work with an exterior door along Irvine St. A new recessed doorway is not applicable.

FINDING: SATISFIED. The City concurs with the applicant’s findings. The floor plan and rendering provided with the application materials depict the recessed entry and transparent door proposed on the south (Third Street facing) façade, as seen below:

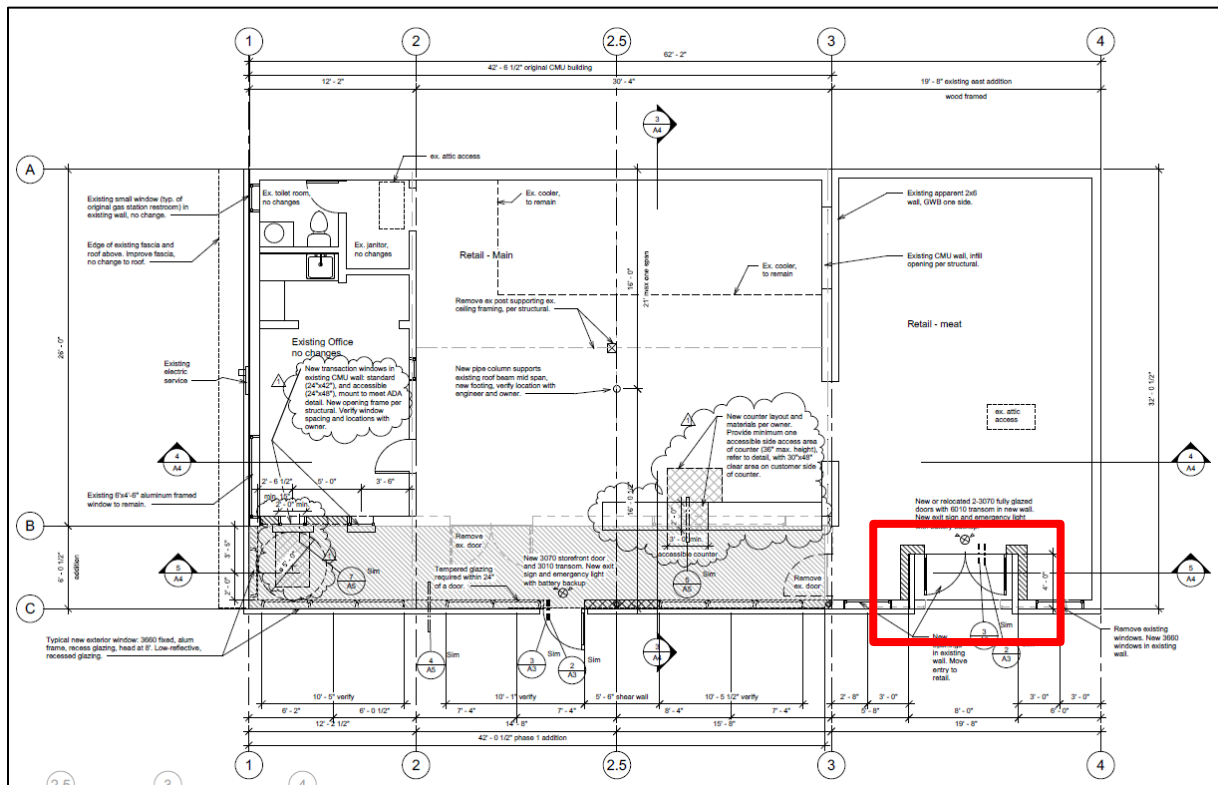

17.59.050 Building and Site Design

B. Building Design. [...]

- 3. Storefronts (that portion of the building that faces a public street) should include the basic features of a historic storefront, to include: [...]
 - e. Decorative cornice or cap at the roofline.

APPLICANT’S RESPONSE: A new decorative cornice or cap trim will be provided at the improved parapet façade at the roofline.

Attachments :

Attachment 1 – Application and Attachments

FINDING: SATISFIED. The City concurs with the applicant’s findings. The cornice/cap trim can be seen below:

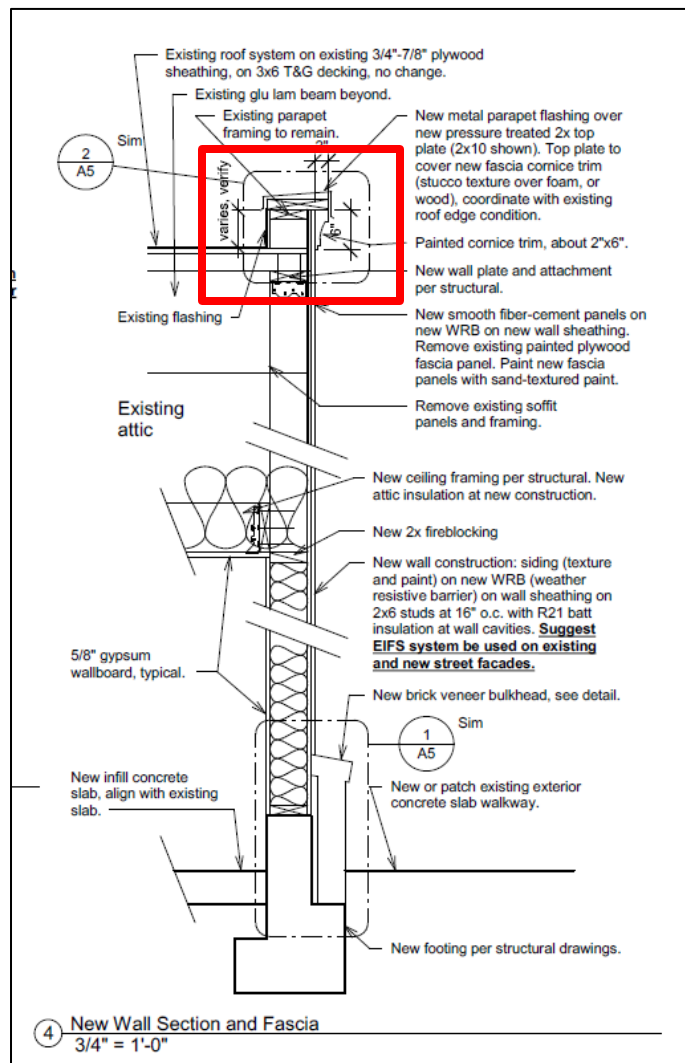
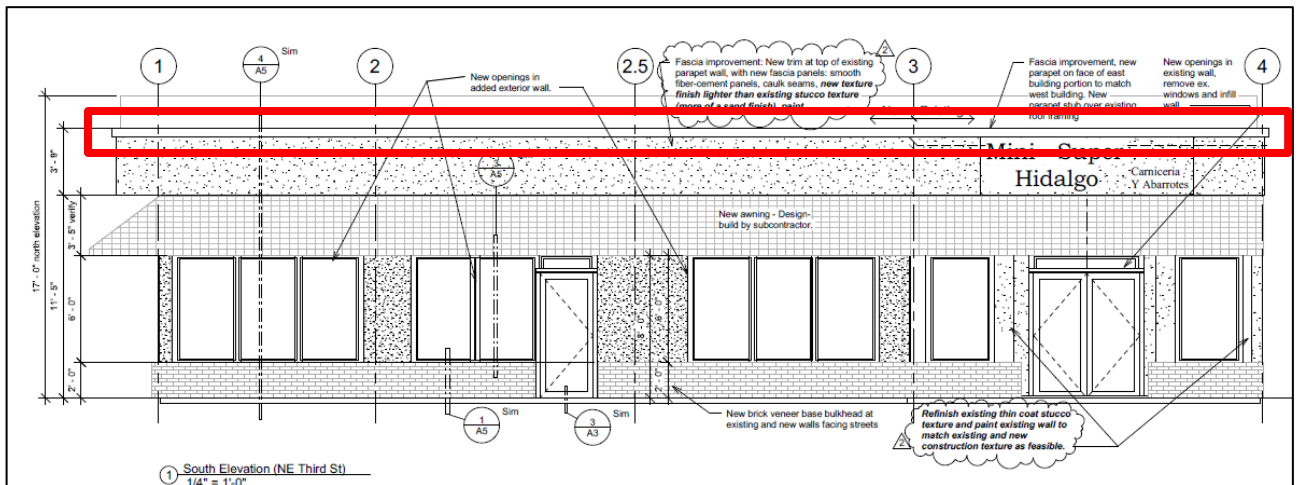

17.59.050 Building and Site Design

B. Building Design. [...]

4. Orientation of rooflines of new construction shall be similar to those of adjacent buildings. Gable roof shapes, or other residential roof forms, are discouraged unless visually screened from the right-of-way by a false front or parapet.

APPLICANT’S RESPONSE: No change to rooflines proposed. Existing roof is very low pitched, screened towards public streets behind improved existing parapet façade.

FINDING: SATISFIED. The City concurs with the applicant’s findings.

17.59.050 Building and Site Design

B. Building Design. [...]

5. The primary entrance to a building shall open on to the public right-of-way and should be recessed.

APPLICANT’S RESPONSE: The primary entrance to the building shall be a new recessed entry along the Third St. façade and will open to face the Third St public right-of-way. A second door is added flush along the Third St. façade.

FINDING: SATISFIED. The City concurs with the applicant’s findings, and adds that the recessed entry does not open on to the public right-of-way given that the proposed addition is an infill within existing building lines and the infill of an existing covered area on the south side of the building. The existing building lines are not adjacent to the property line, and therefore, the new recessed entry does not open on to the public right-of-way. However, the recessed entry is connected to the public right-of-way by a concrete pedestrian walkway that extends along the entire south building wall and connects to the sidewalk within the Irvine Street right-of-way. That connection can be seen below:

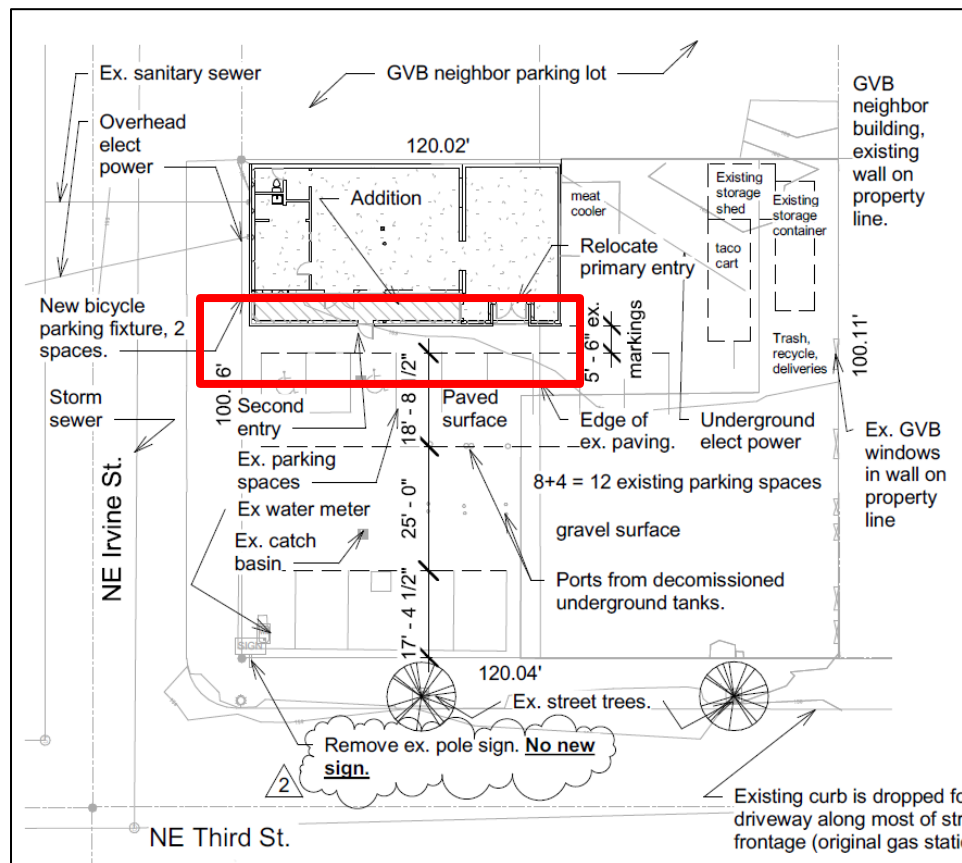

Attachments :

Attachment 1 – Application and Attachments

17.59.050 Building and Site Design

B. Building Design. [...]

- 6. Windows shall be recessed and not flush or project from the surface of the outer wall. In addition, upper floor window orientation primarily shall be vertical.

APPLICANT’S RESPONSE: New windows shall be installed so the glazing is recessed in the new wall, and not flush or project from the surface of the outer wall. New windows are oriented vertically.

FINDING: SATISFIED. The City concurs with the applicant’s findings. A detail showing the windows recessed was provided by the applicant as shown below:

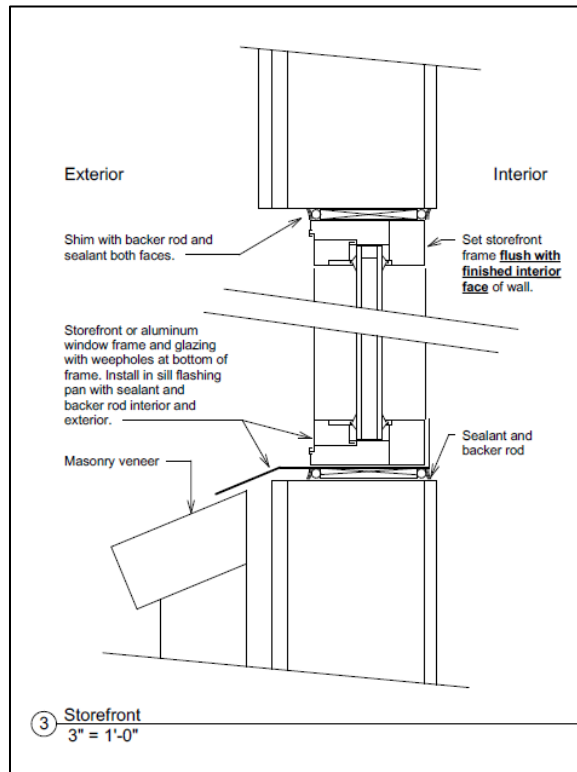

17.59.050 Building and Site Design

B. Building Design. [...]

- 7. The scale and proportion of altered or added building elements, such as new windows or doors, shall be visually compatible with the original architectural character of the building.

APPLICANT’S RESPONSE: The scale and proportion of altered or added building elements, such as new windows or doors, are visually compatible with the original architectural character of the building. The original architectural character of the building is very plain, appearing to be a cross between "convenience store" and "gas station".

FINDING: SATISFIED. The City concurs with the applicant’s findings, and clarifies that the added building elements, including new windows, doors, awnings, fascia, and cornice, change the architectural character of the building. However, the changes result in the building more consistent with the Downtown Design Standards, as described in the findings for each individual standard, rather than maintaining the “convenience store” or “gas station” type of architectural character described by the applicant.

Attachments :

Attachment 1 – Application and Attachments

17.59.050 Building and Site Design

B. Building Design. [...]

8. Buildings shall provide a foundation or base, typically from ground floor to the lower windowsills.

APPLICANT’S RESPONSE: Per item 3b, a new brick veneer base will be provided on Third and Irvine Streets from ground floor to the lower windowsills.

FINDING: SATISFIED. The City concurs with the applicant’s findings.

17.59.050 Building and Site Design

C. Building Materials.

1. Exterior building materials shall consist of building materials found on registered historic buildings in the downtown area including block, brick, painted wood, smooth stucco, or natural stone.

APPLICANT’S RESPONSE: Proposed exterior materials include extending the existing painted stucco finish onto new construction, with a new brick veneer base. The existing painted “stucco” finish on new wood construction will be a thin coat texture system on wood sheathing or fiber-cement panels between new windows and at improved fascia. The improved façade at the parapet will be will include decorative trim at the existing parapet top. New glazing will match existing glazing, and any coating shall be low reflective.

FINDING: SATISFIED WITH CONDITION #2. The City concurs with the applicant’s findings, but adds that the new portions of building wall and the fascia wall are proposed to be either wood sheathing or fiber-cement panels with caulked seams, and then finished with sand-textured paint. Wood siding is prohibited by Section 17.59.050(C)(2)(a). Therefore, a condition of approval is included to require that the new walls and fascia be finished with the fiber-cement panels with caulked seams, and then finished with sand-textured paint. The City finds that this finish is consistent with the appearance of smooth stucco, and because the building is not designated as a historic landmark or within the McMinnville Downtown Historic District this finish is found to be compatible with the list of allowed exterior building materials.

The condition of approval also will require that the applicant provide a built example of the final exterior panel building material to be reviewed and approved by the Historic Landmarks Committee prior to the release of building permits for the proposed development. The built example shall include an example of the treatment of any seam that is to be caulked and painted over with the sand-textured paint.

17.59.050 Building and Site Design

C. Building Materials. [...]

2. The following materials are prohibited for use on visible surfaces (not applicable to residential structure):
 - a. Wood, vinyl, or aluminum siding;
 - b. Wood, asphalt, or fiberglass shingles;
 - c. Structural ribbed metal panels;
 - d. Corrugated metal panels;
 - e. Plywood sheathing, to include wood paneling such as T-111;
 - f. Plastic sheathing; and
 - g. Reflective or moderate to high grade tinted glass.

APPLICANT’S RESPONSE: None.

FINDING: SATISFIED WITH CONDITION #2. A condition of approval is included to ensure that wood siding is not used and that the new walls and fascia be finished with the fiber-cement panels with caulked seams, and then finished with sand-textured paint.

17.59.050 Building and Site Design

C. Building Materials. [...]

3. Exterior building colors shall be of low reflective, subtle, neutral or earth tone color. The use of high intensity colors such as black, neon, metallic or florescent colors for the façade of the building are prohibited except as may be approved for building trim.

APPLICANT’S RESPONSE: Exterior building colors shall be of low reflective, subtle, neutral or earth tone color.

FINDING: SATISFIED WITH CONDITION #3. The applicant provided a rendering of the building that identifies exterior colors. The colors shown in the rendering consist of shades of red, brown and tan, which are generally all subtle, neutral, and earth tones. To ensure that the final colors applied to the building are subtle, neutral, and earth tone in color, a condition of approval is included to require that that the applicant provide samples or examples of the exterior building colors to the Planning Department for review and approval by the Planning Director prior to application on the building.



17.59.060 Surface Parking Lots.

A. Surface parking lots shall be prohibited from locating on Third Street. In addition, vehicular access to parking lots from Third Street is prohibited.

APPLICANT’S RESPONSE: No parking changes required for phase 1. Current existing parking spaces 12. Building shall be entirely Retail use. Building area, existing and with improvements, is 1990 sf. Retail requires 1 off-street parking space per 250 sf building area. 8 parking spaces required for phase 1 total building, which is less than 12 spaces existing. No changes proposed to existing surface parking lot.

FINDING: SATISFIED. The City concurs with the applicant’s findings, given that the proposed addition is an infill within existing building lines and the infill of an existing covered area on the south side of the building. The existing improvements on the site include an off-street parking and internal vehicular circulation area. No changes are proposed to most areas of the site during the expansion of the existing commercial building, as the expansion will be infilling an existing covered area on the front of the building and not impacting any other portion of the site. During the “Phase 2” improvements described by the applicant, additional site improvements and

Attachments :

Attachment 1 – Application and Attachments

parking lot improvements may be required depending on the scale of the proposed future development of the site.

17.59.070 Awnings.

- A. Awnings or similar pedestrian shelters shall be proportionate to the building and shall not obscure the building's architectural details. If transom windows exist, awning placement shall be above or over the transom windows where feasible.

APPLICANT'S RESPONSE: New awnings are proposed on both Third and Irvine Street facades. There are no existing building features to obscure.

FINDING: SATISFIED. The City concurs with the applicant's findings.

17.59.070 Awnings.

- B. Awnings shall be placed between pilasters.

APPLICANT'S RESPONSE: Awnings will be continuous matt finished fabric over metal frame attached to wall.

FINDING: SATISFIED. The City concurs with the applicant's findings.

17.59.070 Awnings.

- C. Where feasible, awnings shall be placed at the same height as those on adjacent buildings in order to maintain a consistent horizontal rhythm along the street front.

APPLICANT'S RESPONSE: There are no existing adjacent buildings to align with, although the awning will be at a similar level to the awnings on Golden Valley Brew Pub. Awnings are shown placed at 8', the head of the new windows and transom over exterior doors.

FINDING: SATISFIED. The City concurs with the applicant's findings.

17.59.070 Awnings.

- D. Awnings should be constructed of soft canvas, fabric, or matte finished vinyl. The use of wood, metal or plastic awnings is prohibited.

APPLICANT'S RESPONSE: Awnings will be continuous matt finished fabric over metal frame attached to wall.

FINDING: SATISFIED. Findings for the waiver described by the applicant are provided in the findings for the waiver review criteria above.

17.59.070 Awnings.

- E. Awnings may be indirectly illuminated; internal illumination of awnings is prohibited.

APPLICANT'S RESPONSE: Awnings will not be internally illuminated.

FINDING: SATISFIED. The City concurs with the applicant's findings.

17.59.070 Awnings.

- F. Awning colors shall be of a low reflective, subtle, neutral or earth tone color. The use of high intensity colors such as black, neon, metallic or florescent colors for the awning are prohibited.

APPLICANT’S RESPONSE: Awnings are proposed to be of a low reflective, subtle, neutral or earth tone color.

FINDING: SATISFIED WITH CONDITION #3. The applicant provided a rendering of the building that identifies the color of the awning. The awning color shown in the rendering appears to be a tan color, which is generally subtle, neutral, and of an earth tone. To ensure that the final awning color applied to the building is subtle, neutral, and earth tone in color, a condition of approval is included to require that the applicant provide samples or examples of the exterior building colors to the Planning Department for review and approval by the Planning Director prior to application on the building.

17.59.080 Signs.

A. The use of flush-mounted signs, flag-mounted signs, window signs, and icon signs are encouraged. Sign materials shall be compatible with materials used in the building.

APPLICANT’S RESPONSE: The existing non-compliant pole sign will be removed. Signage will meet design standards:

1. There will not be a new monument sign at this time.
2. Flush wall-mounted sign similar to existing, painted wood material, located on fascia above new awning, below building cornice. Sign will be about 40 sf, one sided.

FINDING: SATISFIED. The City concurs with the applicant’s findings, but adds that some of the details of the proposed new signage are clarified below. The proposed wall-mounted, wood sign located on the fascia is located in an acceptable location and of a material (painted wood) that is compatible with the building. This sign can be seen in the elevation below:

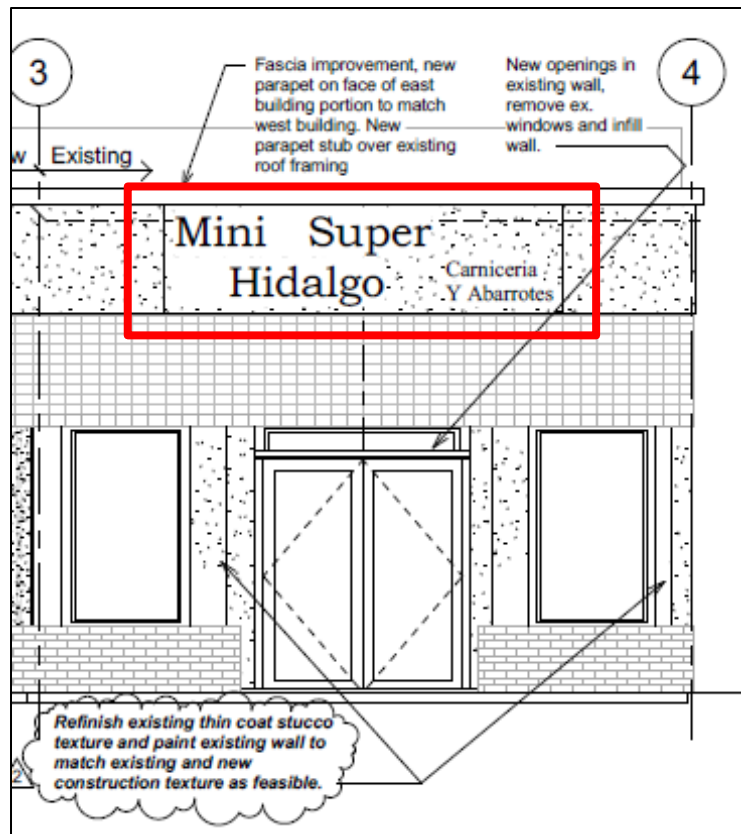

Attachments:

Attachment 1 – Application and Attachments

17.59.080 Signs.

- B. Where two or more businesses occupy the same building, identifying signs should be grouped together to form a single panel.

APPLICANT’S RESPONSE: Single business occupies building.

FINDING: SATISFIED. The City concurs with the applicant’s findings.

17.59.080 Signs.

- C. Wall signs shall be placed in traditional locations in order to fit within architectural features, such as: above transoms; on cornice fascia boards; or, below cornices. Wall signs shall not exceed the height of the building cornice.

APPLICANT’S RESPONSE: None.

FINDING: SATISFIED. The proposed wall-mounted, painted wood sign located on the fascia is located in an acceptable location above the primary recessed entrance to the building. The monument sign will be located near the corner of the site adjacent to the sidewalk and will replace the existing nonconforming pole sign in that portion of the site.

17.59.080 Signs.

- D. For every lineal foot of building frontage, 1.5 square feet of signage may be allowed, to a maximum of 200 square feet.

APPLICANT’S RESPONSE: Building frontage = 62'. Site frontage = 120'.

Signage area allowed: $1.5 \text{ sf} \times 62' = 93 \text{ sf}$ (less than 200 sf).

Signage area proposed = 40 sf, less than 93 sf allowed.

FINDING: SATISFIED. The City concurs with the applicant’s findings, but clarifies that the maximum amount of signage is 93 square feet based on the 62 feet of building frontage, not site frontage. The proposed total size of signage is 40 square feet, which is below the maximum amount of 93 square feet allowed.

17.59.080 Signs.

- E. The use of the following are prohibited in the downtown area:
1. Internally-lit signs;
 2. Flashing signs
 3. Pedestal signs and pole-mounted signs;
 4. Portable trailer signs;
 5. Cabinet-type plastic signs;
 6. Billboards of all types and sizes;
 7. Historically incompatible canopies, awnings, and signs;
 8. Signs that move by mechanical, electrical, kinetic or other means; and,
 9. Inflatable signs, including balloons and blimps. (Ord. 4797 §1, 2003).

APPLICANT’S RESPONSE: The existing non-compliant pole sign will be removed. There are no other prohibited types of signage on the site or existing building. Existing signage is located on the building façade, is modest in size, and will be replaced for phase 1.

FINDING: SATISFIED. The City concurs with the applicant’s findings.

CD

Attachments:

Attachment 1 – Application and Attachments